

STANLEY®

MAKE SOMETHING GREAT™



**Hand Tools
Catalog**

DOORS



HYDRAULIC TOOLS



AIR TOOLS



HAND TOOLS



FASTENING SYSTEMS



MECHANICS TOOLS



HARDWARE



AUTOMATIC DOORS



Welcome to the Stanley Tools Brand Catalog. Whether you're a retailer looking for the best quality products to offer your customers, or a skilled end-user looking for the best tools, Stanley is here to serve you.

Stanley has a reputation for excellence. We continually test, design and improve our products to ensure quality and maximum function. Maintaining our standing of being the world's best at what we do is important to us and what you expect from a name like Stanley.

This catalog features our broad range of carpentry and automotive products. It includes such specialty hand tools as a line of ergonomically designed products, a pro line of tools made of extra durable materials tough enough for the job site, as well as an assortment of products for the home mechanic and homeowner.

We also provide information on how to order other Stanley catalogs featuring products such as Stanley® Goldblatt® Trowel Trade Tools as well as our new **AccuScape™** Garden Tools line of products.

Please look for us on the World Wide Web at our Internet Address: www.stanleyworks.com for information on our latest new products and exciting promotions.

STANLEY®

MAKE SOMETHING GREAT™

TABLE OF CONTENTS

INDEX BY CATEGORY

i

TROWEL TRADE TOOLS / TOOL SETS

2

MERCHANDISING / GARDEN TOOLS

3

BORING TOOLS

4

Bit Braces, Hand and Push Drills, Bits, Screw Hole Starter, Doweling Jig, Circle Cutter, Countersink, Counterbores, Plug Cutters

CUTTING TOOLS

8

Knives, Knife Blades, Planes, Snips, Multi-Tool, Glass and Tubing Cutters, Saws, Specialty Saws, Saw Blades, Mitre Boxes

FINISHING TOOLS

36

Surform® Tools and Blades, Files, Putty Knives and Scrapers

MEASURING TOOLS

42

Tape Rules, Long Tapes, Open Reel Tapes

LAYOUT TOOLS

50

Electronic Tools, Levels, Straight Edges, Squares, Stud Finders, Bevels, Gauges, Compass, Chalk Line Reels, Chalk Line and Chalk

STRIKING & STRUCK TOOLS

64

Hammers, Sledge Hammers, Soft-Face Hammers, Specialty Hammers, Axes, Goggles, Wood Chisels and Gouges, Metal Chisels and Punches, Bars, Nail Sets

FASTENING TOOLS

78

Screwdrivers, Scratch Awls, Tack Claws, Ice Picks, Magnetic Screwdrivers, Ratchets, Offset Ratchets, Bits, Insert Bits, Drill Points, Tap Wrench, Hex Keys, Hole Starters and Screw Holders, Nut Drivers

MECHANICS TOOLS / TOOL HOLDERS

92

Sockets and Socket Accessories, Tool Sets, Tool Pouches and Holders, Pliers, Nippers, Wire Stripper, Wrenches, Pencils, Clamps, Saw Horse Brackets, Panel Carry

INDEX BY PRODUCT NUMBER

110

A
 Awls 83, 84, 91
 Axes 70

B
 Bars 75, 76
 Bevels 62
 Bit Brace 6
 Bits
 Expansive 6
 Screwdriver .88, 89, 90
 Blades
 Coping Saw 28
 Hacksaws 34
 Sabre Saw 34
 Scraper 41
 Scroll Saw 34
 Surform® Style 39
 Utility Knives .17, 18
 Book, Square 58
 Brackets
 Saw Horse 108

C
 Cabinet Scraper 22
 Carpenter's Pencil 108
 Carrier, Panel 108
 Chalk 63
 Chalk Line Reels 63
 Chisels
 Cold 74
 Wood 72, 73
 Clamps 108
 Compass 62
 Counterbores 7
 Countersink 7
 Cutters
 Circle 7
 Glass 24
 Plug 7
 Tubing 24
 Plane 22

D
 Doweling Jig 7
 Drill
 Hand 6
 Holster 109
 Points 6, 89
 Push 6
 Drywall Tools 2

E
 Electronic Products
 Accessories 53
 Leveling . . .52, 54, 55
 Measurement 53
 Stud Sensors 52

F
 Files 40

G
 Garden Tools 3
 Gauges
 Marking 62
 Mortise 62
 Stair 59
 Goldblatt Trowel 2
 Trade Tools
 Goggles, Safety 70
 Gouges 73

H
 Hammer Safety .66, 67, 68
 Hammers
 Ball Pein 68, 71
 Blacksmith 69
 Bricklayers 68
 Engineers 69, 71
 Framing 66, 67
 Hand Drilling .69, 71
 Nail 66, 67
 Sledge 69, 71
 Soft Face 70, 71
 Tack 70
 Hatchets 70
 Hex Keys 90
 Holsters
 Cordless Drill109
 Knife 13
 Hammer 70
 Honing Guide 22

I
 Ice Pick 84, 91
 (Scratch Awl)
 IntelliTools™ 52-55
 Products

K
 Key Chains
 Mitey-Knife® Style .15
 Tape Rule 46
 Knife Blades 17, 18
 Knife Blade Guide 16
 Knife Holster 13

Knives
 Carpet 10, 12
 Fixed Blade . .12, 13
 High Visibility .11, 12, 15
 Hobby 15
 Insulation 12
 Linoleum 13
 Mitey-Knife® Style .15
 Multi-Purpose 15
 Pocket 15
 Retractable .10-12, 14
 Self-Retracting . .11
 Scoring 13
 Snap-Off 14, 15
 Swivel-Lock .10, 12, 13
 Style
 Trimming 15

L
 Laser Products 52-55
 Level Case 57
 Levels
 I-Beam 56, 57
 Laser 52, 54
 Line 58
 Magnetic .56, 57, 58
 Mason's 56
 Pocket 58
 Torpedo 57, 58
 Utility 58

M
 Mallet 70
 Mandrels 34
 Mitre Boxes 35
 Multi-Tool 24
 (Pocket Shears)

N
 Nail Sets 77
 Nippers 106, 107
 Nut Drivers 91

P
 Panel Carry 108
 Pencils 108
 Planes 20, 21
 Pliers 106, 107
 Plumb Bob 63
 Pocket Shears 24
 Pouches 109
 Pry Bars 75, 76
 Punches 74, 77
 Putty Knives 40

R
 Rasp 40
 Ratchets
 1/4" Drive 94
 3/8" Drive 95
 1/2" Drive 97
 Screwdriver .88, 89, 90
 Razor Blades 17, 41
 Rules
 See Tape Rules

S
 Safety
 Chisels 72
 Goggles 70
 Hammers .66, 67, 68
 Knives 13
 Screwdrivers 83
 Snips 24
 Saw Blades
 Bow 32
 Coping 28
 Folding 30
 Hack 34
 Keyhole 29
 Nest-of-Saws . .31
 Sabre/Jig 34
 Scroll 34
 Saws
 Back 30
 Bow 32
 Compass 28
 Coping 28
 Dovetail 31
 Flush Cut 30
 Folding Pocket . .30
 Hacksaw . . .32, 33
 Hand 25-27
 Hole 34, 35
 Keyhole 29
 Mitre 35
 Multi 30
 Nest of Saws . . .31
 Pruning 31
 Wallboard 29
 Saw Horse Bracket .108
 Saw Protector 26
 Saw Set 34
 Scrapers 22, 41
 Scratch Awls . .83, 84, 91
 Screw Holder 91
 Screw Hole Starters .6, 90

Screwdriver Bits		Ratchets		Tridpod Adapter	53
Drill Points	89	1/4" Drive	94	Tripod	53
Hex	88	3/8" Drive	95	Trowel Trade Tools	2
Insert	90	1/2" Drive	97	W	
Offset	90	Universal Joints		Web Clamp	108
Ratchet	90	1/4" Drive	94	Wing Divider	62
Screwdriver Styles	80	3/8" Drive	96	(Compass)	
Screwdriver Tip	80	1/2" Drive	98	Wire Stripper	107
Configuration		Sockets		Wrenches	
Screwdrivers		1/4" Drive	94, 95	Adjustable	107
4-Way™ Style	88	3/8" Drive	96, 97	Box End	104
100 Plus® Style	82, 83	1/2" Drive	98	Combination	104, 105
Fluted	84, 87	Impact	99	Open End	104, 105
Handyman®	85, 86	Socket Sets		Pipe	108
Style		1/4" Drive	101	Sets	104, 105
High Visibility	88	3/8" Drive	101	Tap	89
Jewelers, Precision	88	1/2" Drive	101	Torque	96, 98
Magnetic Tip	88	1/4" & 3/8" Drive	102		
Ratchet	88, 89, 90	3/4" Drive	102		
Standard	87	Clip Rail	100		
Fluted		Impact	103		
Vinyl Grip	81	Mechanics	103		
Screwstart™ Tool	91	Spokeshave	21		
Sharpening Kit	40	Spring Clamp	108		
Shears	3, 24	Square Book	58		
Snips	23	Squares			
Socket Accessories		Carpenter	58, 59		
3-Way Tool	96	Combination	60		
Adapters		Quick-Square® Style	61		
3/8" Drive	96	Speed	59		
1/2" Drive	98	Try / Mitre	61		
Clip Rails		Straight Edge	58		
1/4" Drive	94	Stair Gauge	59		
3/8" Drive	96	Stud Finders			
1/2" Drive	98	Electronic	52		
Sets	100	Magnetic	62		
Flex Handles		Surform® Tools	38, 39		
3/8" Drive	96	T			
1/2" Drive	98	Tack Claws	84, 85		
Extensions		Tap Wrench	89		
1/4" Drive	94	Tape Rules			
3/8" Drive	96	Digital	53		
1/2" Drive	97	Fractional Read	47		
Spark Plugs		Leverlock®	46, 471		
3/8" Drive	96	Style			
1/2" Drive	98	Long	48		
Speeders		Masons	45		
3/8" Drive	96	MaxSteel™	44, 48		
1/2" Drive	98	Style			
Spinners	94	Open Reel	48		
Torque Wrenches		Pocket	47		
3/8" Drive	96	Powerlock®	44-46		
1/2" Drive	98	Style			
		PowerStop	45		
		Stanley® Tapes	47		

STANLEY®

Goldblatt®

Stanley has an entire line of trowel trade tools designed to be durable and comfortable while meeting the drywall, plaster, concrete, tile and brick and stone needs of the professional mason.

Contact our Customer Service Department at 1-800-262-2161 for your copy of the Stanley® Goldblatt® catalog (T4705).



Tool Sets

Stanley offers an ever changing variety of tool sets at various price point assortments spanning our diverse product categories. Stanley is unique to offer the industry tool sets designed to meet consumer lifestyle needs, and we can do it because of the depth and breadth of our product offering. We also give you a brand name consumers trust in the marketplace. Our sets come in many consumer oriented mixes with value added packaging to spur in-store sales.

Contact your Stanley representative to see what we have to offer you or contact our Customer Service Department at 1-800-262-2161 for the latest Stanley Tool Sets literature.





Garden Tools

We're proud to introduce a broad new line of Stanley **AccuScape™** Precision Garden Tools for professional landscapers and serious home gardeners. With gardening recognized as the number one hobby in America today, the demand for high-quality pruners, loppers, shears and other essentials has never been greater. Stanley's garden tools are designed to meet this demand and deliver the performance our customers expect from us.

Merchandising

Stanley is the premier marketplace leader in providing you with in-store merchandising components designed to introduce new products to your customers. From signage, to countertop displays, to pallet merchandisers, Stanley offers you the proper vehicle to best merchandise product and increase sales.

Speak with your Stanley representative about what we have "in-store" for you!

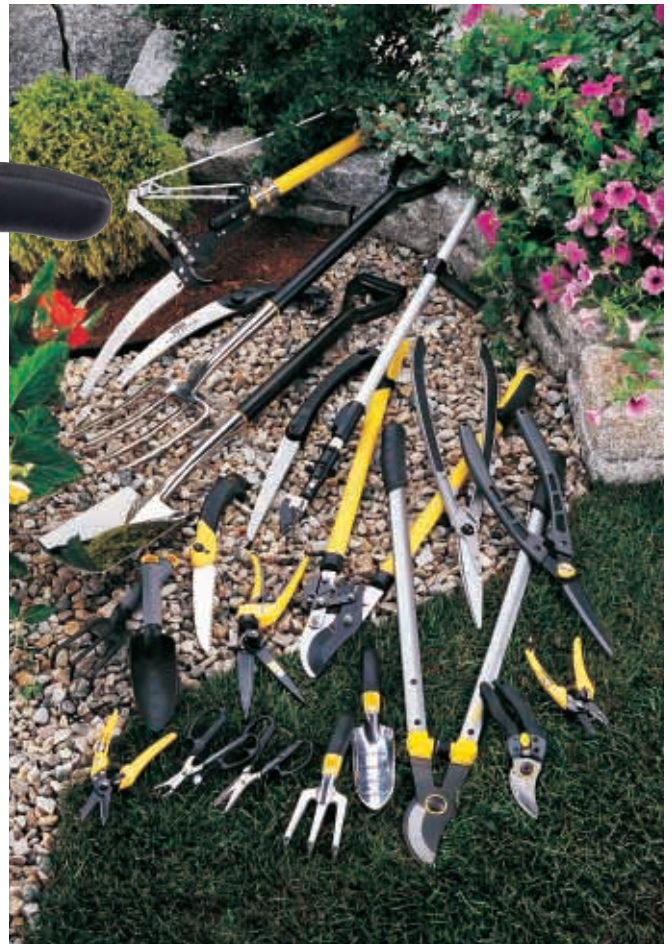

Human-powered braces, hand drills, push drills, and the bits that work with them continue to be effective tools for boring holes in wood and other light materials. They are often more convenient than electric drills for boring pilot holes, working in tight spaces or outside where electricity might not be readily available. They are still the tool of choice among professionals and amateurs for fine woodworking.

Push drills are fast and convenient for boring small holes. Push drills use a ratcheting action to drive in points. The points are specially designed to fit push drill chucks. Points are often stored in the push drill handle.

Braces are used for boring holes from 1/4" using auger bits to 2" or more when fitted with an expansive bit.



STANLEY

BORING TOOLS

Hand drills are for drilling pilot holes up to 1/4" diameter. They have a chuck that hold the bits and pinion gears to increase chuck speed and allow faster, more effective drilling. Stanley® drill point sets include eight points ranging from 1/16" to 11/64".



BIT BRACE

Alligator jaws. Open ratchet bit brace with molded polypropylene head and handle.



Product ID No.	Sweep		Box/Ctn
	Inches	mm	
02-660	10	255	2 / 6

EXPANSIVE BIT

Solid head construction. Easy, positive adjustment for hole diameter. Individually packaged in vinyl pouches.



Product ID No.	Cutter Inches	Length		Box/Ctn
		Inches	mm	
01-710	2 cutters-bores 5/8-1-3/4 holes	9-1/2	245	6 / 144
01-711	2 cutters-bores 7/8-3 holes	9-1/2	245	6 / 144

HAND DRILL

An ideal hand drill for the homeowner or woodworker. Features double pinion gears for smooth operation. Three jaws, sintered iron, 1/4" capacity steel chuck, chrome plated all steel frame.



Product ID No.	Chuck Capacity Inches	Length		Box/Ctn
		Inches	mm	
03-103	1/4	10-3/4	275	1 / 6

HAND DRILL

Solid, smooth running gear. Single pinion. All steel frame. Nickel plated, three jaws, sintered iron steel chuck. 1/4" capacity.



Product ID No.	Chuck Capacity Inches	Length		Box/Ctn
		Inches	mm	
03-105	1/4	10-1/4	260	1 / 6

SCREW HOLE STARTER

Marks, starts and threads the hole for screw to enter. Plastic handle with full size comfortable grip and a heat tempered blade for long life. The point bites fast and clean at the exact spot screw is to be placed while the hole is threaded for easy entry and turning of the screw.



Product ID No.	Overall Length		Box/Ctn
	Inches	mm	
69-008	6-1/2	163	10 / 100

YANKEE® PUSH DRILL

Four drill points. Magazine handle made of tough, plastic material. Contains one each 5/64", 7/64", 9/64" and 11/64" drill points. Handle holds eight bits.

03-046

YANKEE® ECONOMY PUSH DRILL

Economy push drill. Includes 3/32" drill point.

03-049

FINE WOODWORKING PUSH DRILL

Yankee® Pro Push Drill features steel construction for durability. Chuck design holds bits firmly when tool is in use. Magazine handle holds eight drill points. Drill point sizes from 1/16" to 11/64".

03-043

DRILL POINTS FOR YANKEE® PUSH DRILLS

04-069 8 PIECE SET

04-070 4 PIECE SET



03-046

03-049

03-043

04-069

04-070

Product ID No.	Length with Drill Point in Chuck		Box/Ctn
	Inches	mm	
03-046	10-5/16	261	3 / 24

Product ID No.	Length with Drill Point in Chuck		Box/Ctn
	Inches	mm	
03-049	11	280	3 / 24

Product ID No.	Length Inches	Box/Ctn

Product ID No.	Diameter in Inches	Box/Ctn

Product ID No.	Diameter in Inches	Box/Ctn

COUNTERSINK WOOD AND PLASTIC

Produces clean, 82° countersinks in wood and plastic. Fits 1/4" and larger drill chucks. Max. 3,000 RPM.



Product ID No.	Diameter in Inches	Box/Ctn
04-137	1/2	6 / 36

COUNTERSINK WOOD AND METAL

Produces clean, 82° countersinks in soft steel with this tool made of high quality tool steel. Max 3,000 RPM.



Product ID No.	Diameter in Inches	Box/Ctn
04-140	1/2	6 / 36
04-142	5/8	6 / 36
04-144	3/4	6 / 36

SCREW-MATE® ADJUSTABLE DRILL AND COUNTERSINK

Drills for screw thread, body size, countersinks and counterbores. Adjustable for different length screws. 1/4" shank. Fits chuck of power drill or hand drill. Use with fractional size plug cutter. Max. 3,000 RPM.



Product ID No.	Screw Size	Box/Ctn
04-621	No. 6	6 / 0
04-622	No. 8	6 / 0
04-623	No. 10	6 / 0
04-624	No. 12	6 / 0

PLUG CUTTERS

Produces clean, straight plugs for exact fit in counterbored hole. Shank size 1/4". Button tip or flush appearance. For use in drill press only. Max. 3,000 RPM. Use only with Screw Sink™ counterbores.



Not for Screw-Mate® or Adjustable Screw-Mate® tools.

Product ID No.	Screw Sink Number	Screw Size	Box/Ctn
04-721	04-701, 04-702	No. 6	6 / 0
04-722	04-703, 04-704, 04-705, 04-706	No. 8	6 / 0
04-723	04-707, 04-708, 04-709, 04-710	No. 10	6 / 36
04-724	04-711, 07-712	No. 12	6 / 0

Fractional Size, Plug Cutters

Use with Twist Drills, Powerbore® Bits, or Adjustable Screw-Mate® Drill and Countersinks.

Product ID No.	Makes Plug Diameter Inches	Adj. Screw-Mate® Drill and Countersink	Box/Ctn
04-725	3/8	04-621, 04-622, 04-623	6 / 0
04-726	1/2	04-624	6 / 0
04-727	5/8	None	6 / 0

SCREW SINK™ COUNTERBORES

Prepares wood for screws (flush or deep seated) without damaging or splintering wood surface. Ideal for woodworking, cabinet work, boat building and repair. Fits 1/4" and larger chuck. Heat treated bit. Performs three operations accurately. Max. 3,000 RPM.



Product ID No.	Depth in Inches	Screw Size	Box/Ctn
04-702	1	No. 6	6 / 36
04-703	3/4	No. 8	6 / 36
04-704	1	No. 8	6 / 36
04-705	1-1/4	No. 8	6 / 36
04-706	1-1/2	No. 8	6 / 36
04-707	1	No. 10	6 / 36
04-708	1-1/4	No. 10	6 / 36
04-709	1-1/2	No. 10	6 / 36
04-711	1-1/2	No. 12	6 / 36

Pic. A Drills accurate pilot hole and clearance hole. Scoring edges cut surface fibers, prevent splintering. Screw head compresses wood fibers exerting clamping force when driven flush.

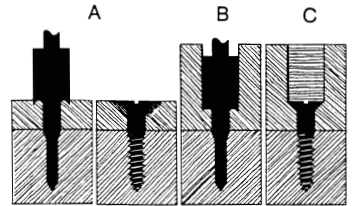

Pic. B To counterbore, simply add more pressure. Chip remover cleans out screw hole as Screw Sink™ Counterbore is withdrawn.

Pic. C Use Stanley Plug Cutter to form perfectly mated plug; leave as "Button Tip" or sand smooth.

5 PIECE SCREW-SINK™ SET

Five popular sizes of Countersinks and Counterbores in a handy plastic kit. Max. 3,000 RPM.



Product ID No.	Depth in Inches	Screw Size	Box/Ctn
04-715 Set includes:	3/4	No. 6	3 / 0
	1	No. 8	
	1-1/4	No. 8	
	1-1/2	No. 10	
	2	No. 12	

DOWELING JIG

Set of six guides. Graduations permit direct reading and accurate setting of jig to center line of work. Capacity 2-7/8" (78mm). Made from aluminum. Guides for power drill bits only — not auger bits.

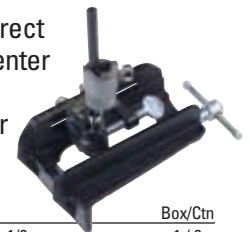

Product ID No.	Guides Furnished in Inches	Box/Ctn
04-059	One each 3/16, 1/4, 5/16, 3/8, 7/16, 1/2	1 / 0

CIRCLE CUTTER

For use in drill press or drill stand only. For cutting circles in laminated materials, hardboard, wood, plywood, etc. Adjustable bit of high speed steel held in arm with set screw. Max. 250 RPM.



Product ID No.	Capacity in Inches	Fits Chuck Inches	Box/Ctn
04-418	1-1/8 to 4-7/8	3/8 and Larger	6 / 24
04-419	1-3/4 to 8-1/4	1/2 and Larger	6 / 24

Cutting tools is an inclusive category containing such diverse tools as knives, planes, and saws in all their wide variety, plus snips for cutting sheet metal, specialty tools, like glass cutters and tubing cutters, and accessories such as mitre boxes. No matter what the cutting tool, however, the key qualities to look for are a comfortable handle, quality materials such as blade steel, and a design that promotes safe use.



Hand saws have been on the job since the days of the Egyptians. Although they still accomplish the same basic task, technology, quality materials, and design innovations make today's saw a tool that craftsmen of the past could only dream of.

Utility knives are as various as the jobs they do. They've come a long way since Stanley® created its first one in 1936. From that single fixed-blade model have come utility knives in a broad variety of sizes and types so users can match just the right knife to the intended job.



STANLEY®

CUTTING TOOLS

Stanley® planes are precision instruments. All are known for sides and bottoms that are machined and ground smooth, flat and true; and for tempered steel cutters, many of them high-carbon steel, precision ground for sharp and long lasting cutting.

STANLEY
FOR GRADE
ERGONOMICS
ANTÍA DE POR VIDA



**CONTRACTOR GRADE™
SUPER HEAVY DUTY RETRACTABLE KNIFE
WITH HOLSTER**

■ Combines retractable blade convenience and safety with the positive blade retention of a fixed blade knife.

Quick blade changes — no screwdriver required. Large, ergonomic handle for comfort and control. Retractable blade with five cutting positions. High-impact polypropylene holster for safe knife storage — even with exposed blade.



Product ID No.	—Handle Length—		Box/Ctn
	Inches	mm	
10-122	7-1/4	184	6 / 24
10-122B Bulk	7-1/4	184	6 / 24



**Reduced Slip
Comfort Grip
Reduced Heat/
Cold Transfer**



**CONTRACTOR GRADE™
DYNAGRIP™ RETRACTABLE
UTILITY KNIFE**

■ Cushion grip surface for comfort. Non-slip grip even with gloved hands.

Patented Interlock® nose to secure blade. Resistance to slipping even on angled surface. Additional comfort in extreme temperatures.

Product ID No.	—Handle Length—		Box/Ctn
	Inches	mm	
10-779	5-5/8	144	6 / 36

**CONTRACTOR GRADE™
SWIVEL-LOCK®
RETRACTABLE UTILITY
KNIFE**

Handle swivels open for quick, easy blade changes: no need for a screwdriver. Interlocking nose secures knife halves together to prevent spreading. Aluminum body for maximum durability. Large, comfortable handle design allows for extended use. Three Heavy Duty blades in handle.

10-989



10-989

**CONTRACTOR GRADE™
RETRACTABLE CARPET
KNIFE**

Retractable blade for controlling depth of cut. Three carpet knife blades in handle. Angled handle design provides easy access to hard-to-reach places.

10-525



10-525

**99® RETRACTABLE
UTILITY KNIFE**

Top and bottom overlap nose to hold blade securely. Multi-position blade slide. Blade storage in handle. Furnished with three each 11-921 Heavy Duty blades.

10-099



10-099

**INTERLOCK® RETRACTABLE
UTILITY KNIFE**

Patented Interlock® nose for safety. Three position retractable blade. Contoured handle with non-slip grip. Furnished with three each 11-921 Heavy Duty utility blades.

10-079



10-079

Product ID No.	Number of Blades	—Handle Length—		Box/Ctn
		Inches	mm	
10-989	3	7	178	6 / 72
10-525	3	6-1/2	165	6 / 72
10-099	3	6	152	6 / 36
10-079	3	5-3/8	149	6 / 72

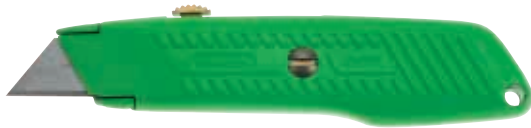

HIGH VISIBILITY INTERLOCK® RETRACTABLE UTILITY KNIFE

High visibility color makes it easy to find in tool box, cabinet, or pouch. Interlock® nose design secures blade safely between knife halves, even in the most demanding applications. Contoured handle with diagonal ribs for a positive, non-slip grip. Furnished with three 11-921 Heavy Duty utility blades.

Product ID No.	Color	Number of Blades	—Handle Length—		Box/Ctn
			Inches	mm	
10-179	Orange and Green	3	5-5/8	144	6 / 72



INTERLOCK® SELF-RETRACTING UTILITY KNIFE

■ Spring-loaded blade retracts into knife automatically when pressure on slide button is released.

Knife can't be left around or put in a pocket with the blade exposed. Interlock® nose secures blade safely between knife halves. Safety-orange color for high visibility. Furnished with one 11-987 Round Point utility blade.

Product ID No.	Color	Number of Blades	—Handle Length—		Box/Ctn
			Inches	mm	
10-189 Bulk	Orange	1	5-5/8	144	12 / 72
10-189C Carded	Orange	1	5-5/8	144	6 / 72



INTERLOCK® NOSE FEATURE JOINS OVERLAPPING KNIFE HALVES TO SECURE BLADE.



QUICK CHANGE RETRACTABLE UTILITY KNIFE

Change blades quickly without a screwdriver. Three position retractable blade slide. Swing-out blade storage magazine. String cutting feature — blade does not have to be exposed. Furnished with three 11-921 Heavy Duty utility blades.

Product ID No.	Number of Blades	—Handle Length—		Box/Ctn
		Inches	mm	
10-499	3	6	152	6 / 72

HOMEOWNER'S RETRACTABLE UTILITY KNIFE

Lightweight, economical utility knife with three position retractable blade. Interlocking overlap nose secures blade safely between knife halves.

Furnished with two 11-921 Heavy Duty utility blades.

Product ID No.	Number of Blades	—Handle Length—		Box/Ctn
		Inches	mm	
10-175	2	6-1/8	156	6 / 72



HIGH VISIBILITY HOMEOWNER'S RETRACTABLE UTILITY KNIFE

Strong, lightweight handle with interlocking overlap nose design to secure blade safely between knife halves.

High visibility color makes knife easy to find. Three position retractable blade slide. Perfect for the do-it-yourselfer.

Product ID No.	Color	Number of Blades	—Handle Length—		Box/Ctn
			Inches	mm	
10-176	High Visibility Green	2	6-1/8	156	6 / 72
10-177	High Visibility Orange	2	6-1/8	156	6 / 72



RETRACTABLE BLADE KNIVES are a good choice for general use, and offer the convenience of being able to quickly adjust the cutting depth of the blade plus the safety of allowing the blade to be retracted completely into the handle when not in use.

PLASTIC RETRACTABLE UTILITY KNIFE

Versatile plastic body knife. Great for a variety of light duty cutting and trimming jobs. Unique snap closure allows quick blade changes. No need for a screwdriver. Five position retractable blade. Furnished with one 11-921 Heavy Duty utility blade. For light duty use only.

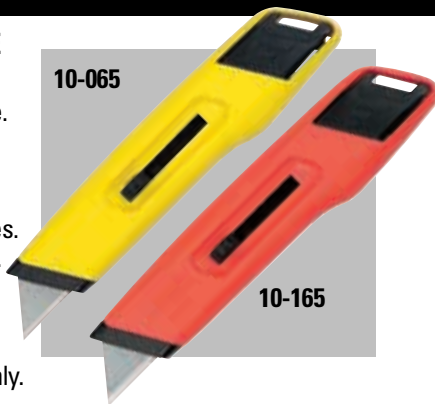

Product ID No.	Number of Blades	—Handle Length—		Box/Ctn
		Inches	mm	
10-065	1	6	152	6 / 36

HIGH VISIBILITY PLASTIC RETRACTABLE UTILITY KNIFE

Plastic retractable utility knife in three assorted high visibility colors. Furnished with one 11-921 Heavy Duty utility blade.

Product ID No.	Number of Blades	—Handle Length—		Box/Ctn
		Inches	mm	
10-165	1	6	152	6 / 72

INSULATION CUTTER

■ Transparent shield safely compresses batts of insulation for cutting to width and protects hand from contact with abrasive or hazardous materials while cutting. Easily slips on and off all standard size utility knives — no other tools needed. Comes with standard utility knife.



Product ID No.	Box/Ctn
10-113	0 / 4

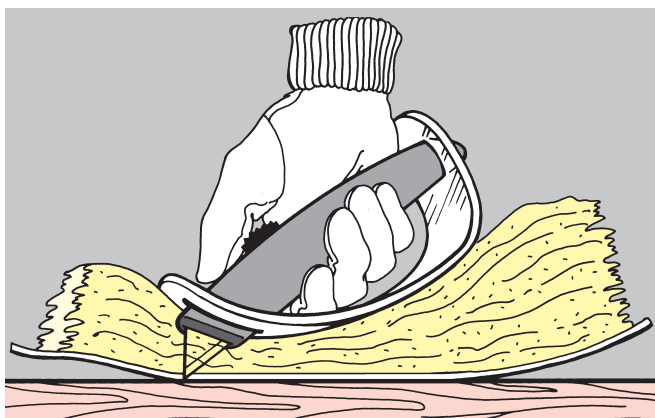

TRANSPARENT SHIELD SAFELY COMPRESSES BATTS OF INSULATION FOR CUTTING.

CONTRACTOR GRADE™ SUPER HEAVY DUTY FIXED BLADE UTILITY KNIFE

■ Positive fixed blade retention for heavy duty cutting. Quick blade changes — no screwdriver required.

Large, ergonomically designed handle for comfort and control. High-impact polypropylene holster for safe knife storage — even with exposed blade. Strong, lightweight aluminum handle with solid brass fastener.



Product ID No.	—Handle Length—		Box/Ctn
	Inches	mm	
10-550	7	178	6 / 24
10-550B Bulk	7	178	6 / 24



CONTRACTOR GRADE™ 199® FIXED BLADE UTILITY KNIFE

Positive fixed blade retention for heavy-duty cutting. Extra heavy duty cast aluminum textured handle designed for long life and tough use. Top and bottom overlap nose. Accepts all Stanley utility knife replacement blades including the 11-931 Extra Heavy Duty Blade. Three blades in handle.

Product ID No.	Number of Blades	—Handle Length—		Box/Ctn
		Inches	mm	
10-209	3	5-1/2	140	6 / 72

SWIVEL-LOCK® CARPET KNIFE

Handle swivels open for quick, easy blade change. Contoured handle for comfort and control. Angular shape for hard-to-reach places. Furnished with three 11-525 Double Edge Carpet blades.



Product ID No.	Number of Blades	—Handle Length—		Box/Ctn
		Inches	mm	
10-520	3	5-3/4	146	6 / 36

FIXED BLADE KNIVES lock blades into a fixed, non-retractable position between the halves of the knife handle. This improves blade stability in severe cutting applications and allows the knife to accept special-purpose blades that are too large to retract into the handle.

FIXED BLADE SWIVEL-LOCK® KNIFE

Handle swivels open for quick, easy blade change. Interlocking nose design for safety. Comfortable, contoured handle. Furnished with three 11-921 Heavy Duty utility blades.

10-399



299® FIXED BLADE INTERLOCK® UTILITY KNIFE

Patented Interlock® nose for safety. Contoured handle with non-slip grip. Blade storage in handle. Furnished with three 11-911 utility blades.

10-299

FIXED BLADE SCORING KNIFE

Designed for scoring clean, true breaks in Formica® and other heavy laminated materials, as well as Plexiglas®, plastic, roofing, flooring, etc. Extra long, heavy-duty blade provides good visibility for use with a straight edge. Comfortable textured handle. Furnished with one 11-942 Heavy Duty Scoring knife blade.

10-519

Product ID No.	Number of Blades	—Handle Length—		Box/Ctn
		Inches	mm	
10-399	3	6	152	6 / 72
10-299	3	5-1/2	140	6 / 36
10-519	1	5-1/2	140	6 / 36

LINOLEUM FLOORING KNIFE

For cutting and trimming vinyl or linoleum floor covering, roofing and similar material. Taper ground cutlery steel blade permanently fastened to comfortable hardwood handle.

Product ID No.	—Handle Length—		Box/Ctn
	Inches	mm	
10-509	4-1/2	127	6 / 72



LEATHER UTILITY KNIFE HOLSTER

Top grain leather holster fits all Stanley utility knives “quick draw” design eliminates interference with blade slide buttons on retractable utility knives. Long belt slots fit extra wide tool belts.

Product ID No.	—Center Length—		Box/Ctn
	Inches	mm	
10-190	8-1/8	206	6 / 36

KNIFE AND BLADE SAFETY

- Always be sure that blades are properly seated in knives and that knives are properly closed and/or fastened together before use.
- Never leave a knife unattended with the blade exposed.
- Always use sharp blades. A dull blade requires more force and is more likely to slip than a sharp one. Change the blade whenever it starts to tear instead of cut.
- Protect your eyes—wear safety goggles when working with knives or any other tools.
- Always keep your free hand away from the line of cut.
- When making cuts on a surface below you, stand or kneel to one side of the line of the cut.
- Always pull the knife toward you when making a cut on a flat surface. A pulling motion is stronger and more positive than pushing the knife away from you, and the knife is less likely to slip.
- When using a straight edge to guide a cut, either clamp it down or keep your free hand well away from the cutting path of the knife. Be sure the straight edge is thick enough to prevent the knife from “riding up” over the edge and cutting you.
- Don't bend or apply side loads to blades by using them to open cans or pry loose objects. Blades are brittle and can snap easily.
- When using a knife to cut through thick materials, be patient—make several passes, cutting a little deeper into the material with each pass.

*FORMICA is a registered trademark of Formica Corporation.
†PLEXIGLAS is registered trademark of Rohm and Haas Company.

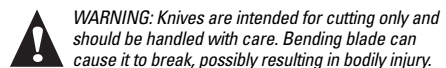



**CONTRACTOR GRADE™
SUPER HEAVY DUTY 18MM
SNAP-OFF BLADE KNIFE**

■ Large, ergonomically designed handle. Aluminum body for strength without unnecessary weight. Supplied with high-impact plastic holster for safe storage — even with exposed blade. Solid brass wheel for secure clamping of blade in use and when retracted. Extra thick blades available in segmented and non-segmented formats. Standard thickness 18mm blades (11-301) will also fit.



Product ID No.	—Handle Length—		Box/Ctn
	Inches	mm	
10-218	7-1/4	184	6 / 24
10-218B Bulk	7-1/4	184	6 / 24



EXTRA THICK BLADE — STRONGER UNDER SIDE PRESSURE.



SEGMENTED BLADE — QUICK REPLACEMENT OF DULL EDGES.



NON-SEGMENTED BLADE — IDEAL FOR CUTTING FOAM.

SNAP-BLADE KNIVES, like Stanley's Quick-Point™ knives, are built around a blade designed to snap off or break away in sections, providing a fresh, sharp cutting point without having to open the knife. These Knives are a good choice for light and medium duty applications, or when adhesive materials, like packing tape, leave a residue on the blade making a fresh, sharp edge critical.



QUICK POINT™ KNIFE 9 MM

Retractable blade knife with 9mm Quick-Point™ snap-off blades. For light duty cutting and trimming. Blade sections snap-off providing the user with 13 fresh, sharp cutting points. Comes with one 11-300 Quick-Point™ blade.

Product ID No.	Number of Blades	—Handle Length—		Box/Ctn
		Inches	mm	
10-150	1	5-1/8	130	6 / 72



QUICK POINT™ KNIFE 18 MM

Retractable blade knife with 18mm Quick-Point™ snap-off blades for light/regular duty cutting and trimming. Blade sections snap-off providing the user with 8 fresh, sharp cutting points. Full grip handles for extra leverage. Comes with one 11-301 Quick-Point™ blade.

Product ID No.	Number of Blades	—Handle Length—		Box/Ctn
		Inches	mm	
10-151	1	6-1/2	165	5 / 50



**CONTRACTOR GRADE™
DYNAGRIP™ SNAP-OFF CARTRIDGE KNIFE**

■ Features a blade cartridge which rapidly and automatically slides new blade into position in a single movement. Cartridge dispenser is made from stainless steel and takes up to six segmented or five extra thick blades. It comes with four spare blades. The smooth slider mechanism features an audible click-stop and is self locking for greater blade security. In addition, the blade clamp ensures that any blade used is locked firmly in position. Very strong and durable tri-material construction featuring soft grip panels for a better grip in use and a stainless steel barrel to prevent rust. Ergonomically designed for better comfort and control. Uses 18mm standard, heavy duty and extra thick non-segmented blades.

Product ID No.	Number of Blades	—Handle Length—		Box/Ctn
		Inches	mm	
10-480	4	6-3/4	170	6 / 36



SELF-LOCKING SNAP-OFF CARTRIDGE KNIFE

■ Features a blade cartridge which rapidly and automatically slides new blade into position in a single movement. Cartridge dispenser system offers safe blade storage. The blade cartridge is made from stainless steel and takes up to six blades. It comes with three spare blades. The smooth slider mechanism features an audible click-stop and is self locking for greater blade security. Made from strong and durable ABS plastic. Uses 18mm standard, heavy duty and extra thick non-segmented blades.

Product ID No.	Number of Blades	—Handle Length—		Box/Ctn
		Inches	mm	
10-380	3	6-5/8	168	12 / 72



STANDARD SNAP-OFF 18 MM KNIFE

■ Made from strong, durable ABS plastic with stainless steel barrel. Ergonomically designed for better comfort and control in use.

Smooth slider mechanism features audible click-stop. Self-locking for greater blade security. Detachable end cap slotted for safer blade break-off. High visibility spare blade holder designed to prevent injury. Comes with one spare 18mm blade. Can be used with 18mm standard segmented and heavy duty, extra thick non-segmented blades.

Product ID No.	Number of Blades	—Handle Length—		Box/Ctn
		Inches	mm	
10-280	1	6-3/4	170	12/72



POCKET KNIFE

Black powder coated handle. Safety blade lock. Replaceable stainless steel blade.

Product ID No.	—Handle Length—		Box/Ctn
	Inches	mm	
10-049	4-1/4	105	6/72



METAL MITEY-KNIFE® POCKET KNIFE

Rugged metal body. Same silhouette as Stanley Interlock® knives. Retractable blade with two cutting positions. Two blades and handy keychain included.

Product ID No.	Number of Blades	—Handle Length—		Box/Ctn
		Inches	mm	
10-239	2	3-1/2	90	6/36



MITEY-KNIFE® KEY CHAIN POCKET KNIFE

Two position retractable blade slide. Blade storage in handle. Handy key chain included. Furnished with two 11-031 blades.

Product ID No.	Number of Blades	—Handle Length—		Box/Ctn
		Inches	mm	
10-039	2	3-1/2	90	6/36

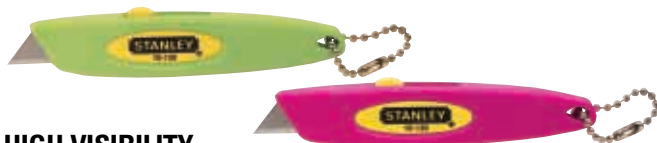

HIGH VISIBILITY MITEY-KNIFE® POCKET KNIFE

Reinforced plastic body weighs less than one ounce. Two assorted, easy-to-locate, high-visibility colors: green and fuchsia. Retractable blade with two cutting positions. Two blades and handy keychain included. Furnished with two 11-031 Mitey-Knife® blades.

Product ID No.	Color	Number of Blades	—Handle Length—		Box/Ctn
			Inches	mm	
10-139	Green & Fuchsia	2	3-1/2	90	6/36



CONTRACTOR GRADE™ SUPER HEAVY DUTY SLIMKNIFE® TRIMMING KNIFE

■ Compact, ergonomically designed handle. Fits a wide range of blades (11-111, 11-113, 11-114).

Simple swivel action allows quick blade changes without a screwdriver. Strong, lightweight aluminum handle with solid brass wheel nut. Handy high-impact plastic holster for safe storage — even with exposed blade. Includes five blades.



Product ID No.	Number of Blades	—Handle Length—		Box/Ctn
		Inches	mm	
10-127	5	5-1/4	133	6/36
10-127B Bulk	5	5-1/4	133	6/72



HOLSTER FOR BLADE PROTECTION.



SWIVEL ACTION FOR QUICK BLADE CHANGE.



RETRACTABLE SLIMKNIFE® MULTI-PURPOSE KNIFE

Multi-purpose retractable knife accepts a wide variety of hobby and craft blades for cutting, whittling, trimming, modeling, etc. Slim, lightweight handle is shaped for a comfortable grip and provides extra blade storage. Easy blade changes. Furnished with one 11-111, 11-113, and 11-114 blades.

Product ID No.	Number of Blades	—Handle Length—		Box/Ctn
		Inches	mm	
10-109	1	6	152	6/72























HOBBY KNIFE

Precision hobby knife available with a strong, light aluminum body. Great for home, office, studio, or workshop. Positive metal barrel blade locks and accept standard hobby and craft blades.

Product ID No.		—Handle Length—		Box/Ctn
		Inches	mm	
10-401	Light Duty	5	127	5/50
10-402	Medium Duty	5	127	5/50

KNIVES & BLADES SELECTION GUIDE				UTILITY BLADES				HOOK BLADES		SPECIALTY BLADES			CARPET BLADES		SNAP-OFF BLADES		POCKET/HOBBY/CRAFT BLADES							
ITEM NO.	PRODUCT NAME	KNIFE TYPE	APPLICATION	11-931	11-921	11-987	11-911	11-961	11-983	11-942	11-941	11-980	11-530	11-525	11-301	11-300	11-040	11-041	11-031	11-111	11-113	11-114	11-411	
10-122	CG Super HD	Retractable	Super Heavy Duty		▲	▲	▲	▲	▲		▲													
10-779	CG DynaGrip™	Retractable	Heavy Duty		▲	▲		▲	▲		▲													
10-989	CG Swivel-Lock®	Retractable	Heavy Duty		▲	▲		▲	▲		▲													
10-079/179	Interlock®	Retractable	Regular/Heavy Duty		▲	▲		▲	▲		▲													
10-499	Quick-Change	Retractable	Regular/Heavy Duty		▲	▲		▲	▲		▲													
10-099	99° Knife	Retractable	Regular/Heavy Duty		▲	▲		▲	▲		▲													
10-113	Insulation Cutter	Retractable	Light/Regular Duty		▲	▲		▲	▲															
10-175/176/177	Homeowners	Retractable	Light/Regular Duty		▲	▲		▲	▲															
10-065/165	Plastic	Retractable	Light Duty		▲	▲		▲	▲															
10-189	Interlock®	Self-Retracting	Heavy Duty		▲	▲		▲	▲		▲													
10-550	CG Super HD	Fixed Blade	Super Heavy Duty	▲	▲	▲	▲	▲	▲															
10-209	199°	Fixed Blade	Heavy Duty	▲	▲	▲	▲	▲	▲	▲	▲	▲												
10-399	Swivel-Lock	Rixed Blade	Regular/Heavy Duty		▲	▲		▲	▲		▲													
10-299	Interlock® 299°	Fixed Blade	Regular/Heavy Duty		▲	▲	▲	▲	▲		▲													
10-525	Retractable	Carpet	Carpet Cutting										▲	▲										
10-520	Swivel-Lock®	Carpet	Carpet Cutting										▲	▲										
10-218	CG Super HD	Snap-Off	Heavy Duty													▲								
10-480	CG DynGrip	Snap-Off	Heavy Duty													▲								
10-330	Self-Locking	Snap-Off	Heavy Duty													▲								
10-280	Standard	Snap-Off	Heavy Duty													▲								
10-151	Quick-Point™	Snap-Off	Light/Regular Duty													▲								
10-150	Quick-Point	Snap-Off	Light Duty														▲							
10-049	Pocket Knife	Folding	Sport, Hobby, Craft														▲	▲						
10-239	Mitey-Knife	Keychain	Light Duty																▲					
10-039/139	Mitey-Knife	Keychain	Light Duty																	▲				
10-127	CG Slimknife	Hobby/Craft	Trimming																		▲	▲	▲	
10-109	Slimknife	Hobby/Craft	Hobby, Craft, Trimming																			▲	▲	▲
10-402	#2 Hobby	Hobby/Craft	Hobby, Craft Art																			▲	▲	▲
10-401	#1 Hobby	Hobby/Craft	Hobby, Craft Art																					▲

KNIFE BLADES

ITEM NO.	DESCRIPTION	THICKNESS
 11-931	Extra Heavy Duty Utility Blade	0.035"
 11-921	Heavy Duty Utility Blade	0.025"
 11-987	Round Point Utility Blade	0.025"
 11-911	Regular Duty Utility Blade	0.017"
 11-961	Hook Blade	0.025"
 11-983	Large Hook Blade	0.025"
 11-942	Heavy Duty Scoring Knife Blade	0.035"
 11-941	Utility Scoring Blade	0.025"
 11-980	Linoleum Blade	0.031"
 11-530	Heavy Duty Carpet Blade	0.017"
 11-525	Standard Carpet Blade	0.015"
 11-301	18mm Quick-Point™ Blade	0.020"
 11-300	9mm Quick-Point™ Blade	0.017"
 11-040	Sheepfoot Pocket Blade	0.040"
 11-041	Utility Pocket Knife Blade	0.040"
 11-031	Mitey-Knife® Blade	0.017"
 11-111	Whittling Craft Blade	0.025"
 11-113	Low Angle Craft Blade	0.025"
 11-114	Curved Craft Blade	0.025"
 11-411	No. 11 Hobby Knife Blade	0.020"

EXTRA HEAVY DUTY UTILITY BLADE

For cutting thick, dense sheet materials. For use with fixed blade knives only.

11-931

1992® HEAVY DUTY UTILITY BLADE

Standard 1992® Heavy Duty, high carbon steel blades are .025" thick. Precision-honed edge for consistent and extended cutting life. Fits most standard utility knives.

11-921

ROUND POINT UTILITY BLADE

Reduces risk of accidental cuts and reduces damage to interior contents when cutting open cartons.

11-987

1991® REGULAR DUTY UTILITY BLADE

Regular duty utility blade for light sheet materials. Five blades per card. Recommended for fixed blade knives only.

11-911

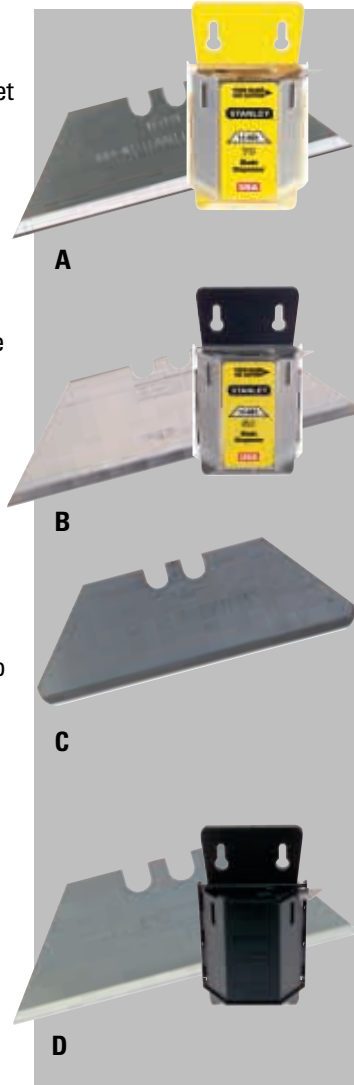

A. Extra Heavy Duty Utility Blade

Product ID No.	Packed	Length in Inches	Thickness in Inches	Box/Ctn
11-931C*	5/Card	2-7/16	.035	10 / 200
11-931D*	70/Dispenser	2-7/16	.025 See through dispenser	6 / 24
11-931	5/Card	2-7/16	.035	10 / 200
11-931A	100/Box	2-7/16	.035	1 / 10

*11-931C Contractor Grade™ Brand
11-931D Contractor Grade™ Brand

B. 1992® Heavy Duty Utility Blade

Product ID No.	Packed	Length in Inches	Thickness in Inches	Box/Ctn
11-921C*	100/Dispenser	2-7/16	.025 See through dispenser	6 / 24
11-921	5/Card	2-7/16	.025	10 / 200
11-921A	100/Dispenser	2-7/16	.025 See through dispenser	6 / 24
11-921L	50/Dispenser	2-7/16	.025 See through dispenser	6 / 24
11-921T	10 Pack. Disp.	2-7/16	.025	10 / 100

*11-921C Contractor Grade™ Brand

C. Round Point Utility Blade

Product ID No.	Packed	Length in Inches	Thickness in Inches	Box/Ctn
11-987	5/Card	1-7/8	.025	10 / 200
11-988	100/Dispenser	1-7/8	.025 See through dispenser	6 / 24

D. 1991® Regular Duty Utility Blade

Product ID No.	Packed	Length in Inches	Thickness in Inches	Box/Ctn
11-911A	100/Dispenser	2	.017 See through dispenser	6 / 24
11-911	5/Card	2	.017	10 / 200

SINGLE EDGE RAZOR BLADE

Steel-backed high carbon steel blade fits all standard razor blade tools. Replacement blades for Stanley 28-100 and 28-500 scrapers.

11-515/28-510

1996™ HOOK BLADE

Edge protection blade for cutting and trimming roofing materials, linoleum, carpet, fabric, cartons and sheet materials without damage to surfaces below.

11-961

LARGE HOOK BLADE

Similar to 11-961, but with deeper hook for cutting thicker materials.

11-983

SCORING KNIFE BLADE

Scores deep grooves for clean, true breaks in Formica®, Plexiglas® and other laminates and sheet materials. For fixed blade knives only.

11-942



E. Single Edge Razor Blade

Product ID No.	Packed	Length in Inches	Thickness in Inches	Box/Ctn
28-510	10/Box	1-12	.009 See through dispenser	10 / 100
11-515	100/Box	1-1/2	.009	0 / 50

F. 1996™ Hook Blade

Product ID No.	Packed	Length in Inches	Thickness in Inches	Box/Ctn
11-961	5/Card	2-1/16	.025	10 / 200
11-961A	100/Dispenser	2-1/16	.025 See through dispenser	6 / 24

G. Large Hook Blade

Product ID No.	Packed	Length in Inches	Thickness in Inches	Box/Ctn
11-983	5/Card	1-7/8	.025	10 / 200
11-983A	100/Dispenser	1-7/8	.025 See through dispenser	6 / 24
11-984	100/Box	1-7/8	.025	1 / 0

H. Scoring Knife Blade

Product ID No.	Packed	Length in Inches	Thickness in Inches	Box/Ctn
11-942	1/Card	3-5/32	.035	10 / 200

*FORMICA is a registered trademark of Formica Corporation.

†PLEXIGLAS is registered trademark of Rohm and Haas Company.



UTILITY SCORING BLADE

Scores deep grooves for clean, true breaks in Formica®, acrylics, laminates, and sheet materials. Fits most utility knives. Two blades per card.



Product ID No.	Packed	Length in Inches	Thickness in Inches	Box/Ctn
11-941	2/Card	1-13/16	.025	10 / 200

LINOLEUM BLADE

Tempered high carbon steel blade with keen edge for clean, true cuts in vinyl or linoleum floor covering, roofing and similar materials. For fixed blade knives only.



Product ID No.	Packed	Length in Inches	Thickness in Inches	Box/Ctn
11-980	1/Card	3-3/32	.025	6 / 36

HEAVY DUTY CARPET KNIFE BLADE

Heavy duty blued carpet knife blade. Single (1-1/4") slot with double cutting edge. Fits Stanley and most other carpet knives. Blades individually wrapped for safety and corrosion protection.



Product ID No.	Packed	Length in Inches	Thickness in Inches	Box/Ctn
11-530	100/Box	2-1/4	.017	1 / 10

CARPET KNIFE BLADE

High carbon steel blade with double cutting edge. Fits Stanley and most other carpet knives. Five blades per card.



Product ID No.	Packed	Length in Inches	Thickness in Inches	Box/Ctn
11-525	5/Card	2-1/4	.015	10 / 100

18MM QUICK-POINT™ BLADE

Replacement blade with 8 cutting points. Fits Stanley 10-218, 10-151 snap-off blade knives and most other 18mm snap-off blade knives.



Product ID No.	Packed	Length in Inches	Thickness in Inches	Box/Ctn
11-301	3/Card	4-1/4	.020	10 / 50

9MM QUICK-POINT™ BLADE

Replacement blade with 13 cutting points. Fits Stanley 10-150 Quick-Point™ snap-off blade knife and most other 9mm snap-off blade knives.



Product ID No.	Packed	Length in Inches	Thickness in Inches	Box/Ctn
11-300	3/Card	3-1/2	.017	10 / 50

MITEY-KNIFE® BLADE

High carbon steel blade. Fits Stanley 10-039, 10-139 and 10-239 Mitey-Knife® products. Three blades per card.



Product ID No.	Packed	Length in Inches	Thickness in Inches	Box/Ctn
11-031	3/Card	1-1/8	.017	10 / 60

REPLACEMENT BLADES FOR 10-049 POCKET KNIFE

Sheepfoot

Sheepfoot style blade made of cutlery stainless steel. For heavy cutting and carving.



Product ID No.	Packed	Length in Inches	Thickness in Inches	Box/Ctn
11-040	1/Card	2-9/16	.040	10 / 60

Utility Blade

Utility blade made from cutlery stainless steel. Designed to perform most any cutting job well.

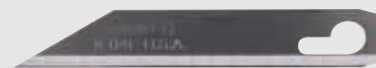

Product ID No.	Packed	Length in Inches	Thickness in Inches	Box/Ctn
11-041	1/Card	2-9/16	.040	10 / 60

NO. 11 HOBBY KNIFE BLADE

For fine angle cutting. Fits Stanley 10-401 Hobby knife.



Product ID No.	Packed	Length in Inches	Thickness in Inches	Box/Ctn
11-411	3/Card	1-9/16	.020	10 / 60

WHITTLING CRAFT BLADE

For whittling, trimming and scoring a variety of materials. Fits Stanley 10-127, 10-109, and 10-402 knives.



Product ID No.	Packed	Length in Inches	Thickness in Inches	Box/Ctn
11-111	3/Card	2-3/8	.025	10 / 60

LOW ANGLE CRAFT BLADE

XXXXX

Product ID No.	Packed	Length in Inches	Thickness in Inches	Box/Ctn
11-113				10 / 60



CURVED CRAFT BLADE

For general cutting, carving, modeling, sheet cutting, trimming, long cuts, cutting flash from plastics, moldings, castings, paper. Fits Stanley 10-127, 10-109, and 10-402 knives.



Product ID No.	Packed	Length in Inches	Thickness in Inches	Box/Ctn
11-114	3/Card	2-1/8	.025	10 / 60

SPECIAL-PURPOSE BLADES (utility, round point, hook, scoring, carpet, linoleum, etc.) are available for a variety of cutting applications.

*FORMICA is a registered trademark of Formica Corporation.



Stanley® Woodworking Planes

For over 125 years Stanley has built a worldwide reputation for making the finest quality planes, engineered to the highest international standards. Over the years, we have maintained traditional standards of workmanship, design and above all performance. The result is probably the finest and most comprehensive range of planes in the world.

Our line of Stanley® Professional Bench planes exemplifies the quality materials and designs which are crafted into all of our planes. Fine gray iron bases are accurately machined and ground for ultimate precision and stability in all working conditions. Adjustments for plane iron alignment, depth of cut and mouth size are simple and precise. Our high chrome carbon steel irons hone quickly to a keen, long lasting edge.

For smooth operation, precision and pride of workmanship, your best choice is Stanley.

CONTRACTOR GRADE™ SMOOTH BOTTOM BENCH PLANE

Cast iron bottom and sides are ground perfectly flat and true. Micro-adjustable mouth opening. Precision ground, replaceable cutter.



Product ID No.	—Length—		—Cutter Width—		Box/Ctn
	Inches	mm	Inches	mm	
12-904	9-3/4	250	2	50	1 / 6

SMOOTH PLANES

Smooth planes for homeowners. Grey iron bottom castings. Cutters are tempered high carbon steel, ground and fully adjustable. Sides and bottoms are machined and ground smooth and true. Bottom castings are finished in enamel with black handles and knobs.



Product ID No.	—Length—		—Cutter Width—		Box/Ctn
	Inches	mm	Inches	mm	
12-203	9-1/2	240	1-3/4	45	1 / 6
12-204	9-3/4	245	2	50	1 / 6
12-204N Display Pack	9-3/4	245	2	50	1 / 6

ADJUSTABLE BENCH PLANE

Easy to use and ideal for general purpose work and final finishing. Solid cast iron base and lever. Tempered high carbon steel cutter. Cutter is fully adjustable for depth of cut and alignment.



Product ID No.	—Length—		—Cutter Width—		Box/Ctn
	Inches	mm	Inches	mm	
12-404 4 Piece Merchandiser	9-3/4	245	2	50	4 / 4

FINE WOODWORKING BAILEY® JOINTER OR TRY PLANE

The Jointer or Try Plane is for the accurate truing of long edges which are to be jointed together as in the production of table tops.



Product ID No.	Length	Blade Width	Box/Ctn
	Inches	Inches	
12-007 #7	22	2-3/8	1 / 0

FINE WOODWORKING BAILEY® CORRUGATED BASE PLANE

All Stanley® Bailey® Bench planes are also available with corrugated bases which reduce friction when the plane is used, particularly on resinous timbers. For this reason, some woodworkers prefer corrugated bases for most of their heavy planing.



Final honing is recommended on all plane irons before use.

Product ID No.	Length	Blade Width	Box/Ctn
	Inches	Inches	
12-014 #4C	9-3/4	2	1 / 6
12-015 #5C	14	2	1 / 6
12-016 #6C	18	2-3/8	1 / 0

CONTRACTOR GRADE™ BLOCK PLANE

Cast iron bottom and sides are ground perfectly flat and true. Fully adjustable cutter rests at 21°. Adjustable mouth opening for course or fine work. Comfortable finger grips on sides. Replaceable cutter.



12-920

12-920

110® BLOCK PLANE

110® Plane recommended for ordinary work that does not require frequent adjustment. Cutter can be adjusted for thickness of shavings by loosening wheel and moving cutter endwise as required.



12-116

12-116

BLOCK PLANE

The cutter is adjustable endwise and sideways and rests on its seat at a 21° angle. Bottom and sides are milled and ground.



12-220

12-220

ADJUSTABLE BLOCK PLANE

Popular priced hand adjustable plane. Bottom ground, tempered steel cutter. Blue finish with cast-in finger rest. Red finish lever. To adjust cutter for thickness of shavings: loosen wheel, move cutter endwise as required.



12-247

12-247

Product ID No.	—Length—		—Cutter Width—		Box/Ctn
	Inches	mm	Inches	mm	
12-920	6	150	1-5/8	40	1 / 6
12-116	7	180	1-5/8	40	1 / 6
12-220	7	180	1-5/8	40	1 / 6
12-220N Display Pack	7	180	1-5/8	40	1 / 12
12-247	6-5/8	166	1-5/8	40	1 / 6

BLOCK PLANE ADJUSTABLE CUTTER

21° cutter angle is ideal for cross grain planing. Solid cast iron base and lever. Tempered high carbon steel cutter. Cutter is fully adjustable for depth of cut and alignment.



Product ID No.	—Length—		—Cutter Width—		Box/Ctn
	Inches	mm	Inches	mm	
12-252	7	180	2-1/8	52	4 / 4

BLOCK PLANE MANUAL ADJUSTABLE CUTTER

Ideal for cross grain planing. Solid cast iron base and lever. Tempered high carbon steel cutter. Cutter is manually adjustable for depth of cut and alignment.



Product ID No.	—Length—		—Cutter Width—		Box/Ctn
	Inches	mm	Inches	mm	
12-253	6	150	2	50	4 / 4



CONTRACTOR GRADE™ SMOOTH BOTTOM JACK PLANES 5® AND 6®

Cast iron bottom and sides are ground perfectly flat and true. Micro-adjustable mouth opening. Precision ground cutter is replaceable.

Product ID No.	—Length—		—Cutter Width—		Box/Ctn
	Inches	mm	Inches	mm	
12-905 5®	14	355	2	50	1 / 6
12-906 6®	18	455	2-3/8	60	0 / 1

JACK PLANE

Jack plane for trimming long boards to size. Tempered high carbon steel cutters are fully adjustable.

Product ID No.	Center Length	—Cutter Width—		Box/Ctn	
		Inches	mm		
12-205	14	355	2	50	1 / 6

CONTRACTOR GRADE™ LOW ANGLE PLANE

Fully adjustable mouth and cutter. Cutter rests at 12° angle for end grain work. Comfortable finger grips in sides. Bottom and sides machined perfectly flat and true. Replaceable cutter.



Product ID No.	—Length—		—Cutter Width—		Box/Ctn
	Inches	mm	Inches	mm	
12-960	6	150	1-3/8	35	1 / 6

SMALL TRIMMING PLANE

Small, light plane, handy for modeling, sculpture, odds and ends of light work. Nickel plated level, black finish bottom.



Product ID No.	—Length—		—Cutter Width—		Box/Ctn
	Inches	mm	Inches	mm	
12-101	3-1/2	90	1	25	4 / 12



CONTRACTOR GRADE™ ADJUSTABLE BULLNOSE RABBET PLANE

Adjustable mouth for coarse or fine work. Will work close into corners. Replaceable cutter.

Product ID No.	—Length—		—Cutter Width—		Box/Ctn
	Inches	mm	Inches	mm	
12-975	4	100	1-3/32	27	1 / 60

CONTRACTOR GRADE™ BULLNOSE RABBET PLANE

Cutter has two seats, one for regular work and the other for bullnose work. Fitted with a spur, a removable depth gauge, and adjustable fence. Replaceable cutter.

Product ID No.	—Length—		—Cutter Width—		Box/Ctn
	Inches	mm	Inches	mm	
12-978	8-1/4	205	1-1/2	38	1 / 0

CONTRACTOR GRADE™ SPOKESHAVE

Spokeshaves are the best tools for shaping chair legs and seats, curved templates and many other kinds of curved work. They are fully adjustable for depth of cut and are available with round bottoms for concave shapes. Adjustable and replaceable cutter. Comes with a vinyl pouch.



Product ID No.	—Length—		—Cutter Width—		Box/Ctn
	Inches	mm	Inches	mm	
12-951	10	255	2-1/8	52	2 / 24

**FINE WOODWORKING
CABINET SCRAPER**

The cabinet scraper is used for fine finishing of hardwood surfaces or where planing is not advisable, such as veneered boards. The double handle design provides control and efficiency. One side of the blade is sharpened square and straight for fine work and the other side has a slight curve for heavier work like removing stains and polishes.



Product ID No.	Length Inches	Blade Width Inches	Box/Ctn
12-080	11-1/2	2-3/4	1 / 0

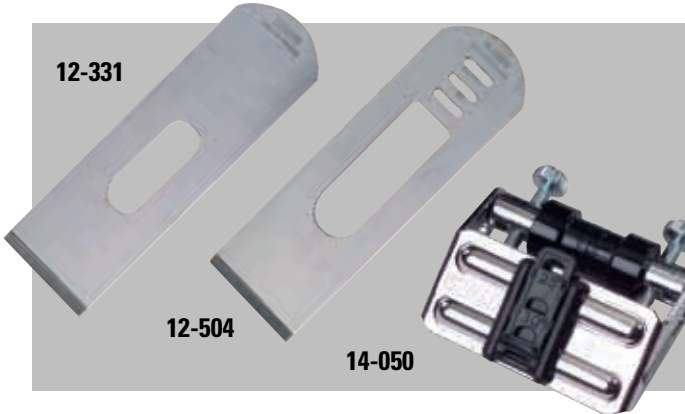

REPLACEMENT CUTTERS

Product ID No.	Plane Number	Cutter Width Inches	Box/Ctn
12-331	12-220	1-5/8	6 / 0
12-338	12-060	1-3/8	6 / 0
12-503	"G" Series		

**FINE WOODWORKING
BLOCK PLANE IRONS**

Stanley replacement plane irons are made from high chrome carbon steel which has excellent edge retention characteristics and allows a razor sharp edge to be honed. All cutters are fine rotary ground to give a flat surface that is easier to sharpen. These irons are supplied with an accurately ground edge of 25°, but before use we recommend an additional honed angle of 30° be applied using a fine sharpening stone and a honing guide.

Product ID No.	Plane Number	Cutter Width	Box/Ctn
12-504	12-960	1-3/8	6 / 0

**FINE WOODWORKING
HONING GUIDE**

To achieve optimum performance from any plane, chisel, or spokeshave, the blade must be sharp. The Stanley® Honing Guide is designed for sharpening blades from 1/8" to 2-3/8" wide and will guide its user to achieve a precise, sharp edge that is square to the blade. Our Honing Guide also features an angle setting gauge with preset markings for 25°, 30°, and 35° to help you achieve the desired hone angle.

Product ID No.	Box/Ctn
14-050 1/8" to 2-3/8" wide	2 / 20

STANLEY® PLANES

Since 1869 the Stanley Plane has been the favorite plane of carpenters, cabinet makers, industrial arts instructors and home craftsmen. Stanley Planes have been constantly improved and refined. Rigid tests and inspection maintains the highest standards possible. Cutters are ground for sharp and long lasting cutting.

PLANE TIPS

- Use the appropriate plane for the work at hand.
- Use Bench Planes to smooth rough surfaces and bring wood down to the correct size.
- Use Jack Planes or longer planes for long distance planing on doors to produce a straight line.
- Use short or trimming planes to dress up short work.



CONTRACTOR GRADE™ AVIATION SNIPS

Blade made of hot drop-forged moly alloy tool steel for long life. Cushioned vinyl grips with molded hang hole for comfort and convenience. Half-hard steel handles will not collapse. Double-overwind spring lasts the life of the tool. Pivot bolt threaded into bottom blade allows for readjustment after extended use.

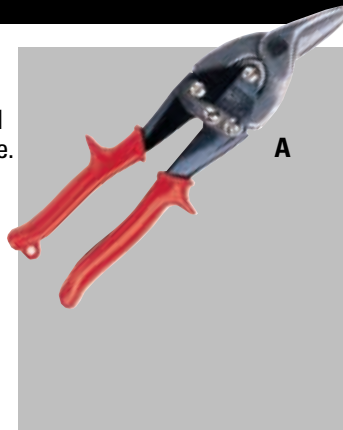

CONTRACTOR GRADE™ OFFSET AVIATION SNIPS

Offset blade snips keep hands safely above work surface on long cuts. Blades of hot drop-forged moly alloy tool steel for long life. Cushioned vinyl grips with molded hang hole for comfort and convenience. Half-hard steel handles will not collapse. Double-overwind spring lasts the life of the tool. Pivot bolt threaded into bottom blade allows for readjustment after extended use.

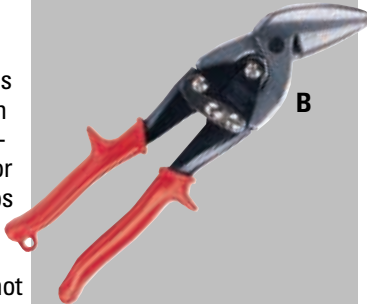

OFFSET AVIATION SNIPS

Tough alloy steel snips with offset blade design — keeps hand safely above work surface on long cuts. Compound leverage, positive lock. Contoured handles with tough vinyl grips. Available in two styles, for left and right curves, both cut straight.

VINYL GRIPS ARE FOR COMFORT ONLY. THEY DO NOT PROTECT AGAINST ELECTRICAL SHOCK.



AVIATION SNIPS

Tough alloy steel blades ground and oiled. Positive lock, contoured handles. Available in three styles, for straight cutting, and for left and right curves. Compound leverage—tough vinyl grips.

VINYL GRIPS ARE FOR COMFORT ONLY. THEY DO NOT PROTECT AGAINST ELECTRICAL SHOCK.

Product ID No.	—O/A Length—		—Cutting Edge—		Box/Ctn
	Inches	mm	Inches	mm	
14-542 <i>Left Curve</i>	9-3/4	248	1-3/8	35	6 / 24
14-543 <i>Straight Cut</i>	9-3/4	248	1-1/2	35	6 / 24
14-544 <i>Right Curve</i>	9-3/4	248	1-3/8	35	6 / 24



ALL PURPOSE SNIPS STRAIGHT PATTERN

Drop-forged steel snips for making straight cuts in metal and other tough sheet materials. Available in three sizes. Cushioned vinyl grips for comfort.

VINYL GRIPS ARE FOR COMFORT ONLY. THEY DO NOT PROTECT AGAINST ELECTRICAL SHOCK.

Product ID No.	—O/A Length—		—Cutting Edge—		Box/Ctn
	Inches	mm	Inches	mm	
14-548	7	180	1-3/4	44	6 / 36
14-549	10	254	2-1/2	64	6 / 36
14-550	12	305	3	76	6 / 36



A. Contractor Grade™ Aviation Snips

Product ID No.	—O/A Length—		—Cutting Edge—		Box/Ctn
	Inches	mm	Inches	mm	
14-755 <i>Left & Straight Cuts</i>	9-3/4	248	1-3/8	35	6 / 24
14-756 <i>Right & Straight Cut</i>	9-3/4	248	1-3/8	35	6 / 24
14-757 <i>Straight Cuts</i>	9-3/4	248	1-1/2	38	6 / 24

B. Contractor Grade™ Offset Aviation Snips

Product ID No.	—O/A Length—		—Cutting Edge—		Box/Ctn
	Inches	mm	Inches	mm	
14-758 <i>Left & Straight Cuts</i>	9-3/4	248	1-1/4	32	6 / 24

C. Offset Aviation Snips

Product ID No.	—O/A Length—		—Cutting Edge—		Box/Ctn
	Inches	mm	Inches	mm	
14-501 <i>Left Curve</i>	9-3/4	248	1-1/2	35	6 / 24
14-502 <i>Right Curve</i>	9-3/4	248	1-1/2	35	6 / 24



**WARNING: WORK SAFELY WITH TOOLS
WEAR SAFETY GOGGLES.**

SNIPS SAFTY TIPS

- Wear safety goggles when using snips.
- Be careful of the sharp edges on the cutting edges of these tools.
- Wear gloves when working with snips.
- Use snips for cutting soft metal only. Hard or hardened metal may damage the cutting edges of the snips.
- Use the right size and type of snips for the job on hand. Don't try to cut sharp curves with straight cut snips.
- Avoid springing the blades. This is the result of trying to cut metal that is too thick for the snips you are using, or by trying to cut heavy wire or nails.
- Use only hand pressure for cutting. Never hammer or use your foot to get extra pressure on the cutting edges. If you are resorting to such a technique, you are using too small a snip — the metal is too thick for the capacity of the snip.
- Oil pivot bolt on the snips occasionally.
- Keep the nut and the bolt properly adjusted at all times.
- The average user does not have the proper equipment to sharpen snips. Do not attempt to sharpen a snip blade in a sharpening device designed for scissors, garden tools or cutlery.
- Do not use “cheater bars” on handles of snips. You are trying to cut material which is too thick if you have to resort to this technique.
- Don't use snips as a hammer, screwdriver or pry bar.
- If the snips you own have locking clips, use them when the tools are not in use.
- Snips should be carefully put away after use.



- Wipe the cutting edges with a lightly oiled rag.
- Don't keep snips in a drawer with other tools.
- Tools with cutting edges should always be treated with extra respect.

GLASS CUTTER

Die cast handle has a wide contoured comfort grip and ball end for tapping. Steel wheel with general purpose cutting angle delivers precise scoring, cleaner breakout, and smoother edges.



Product ID No.	Length		Box/Ctn
	Inches	mm	
14-120	5-1/8	132	10 / 100

TUBING CUTTER

Tubing cutter will cut copper tubing in diameters up to 1-1/8" and has a deburring attachment to ream out any excess material left after cutting. Each tubing cutter comes with a replacement cutting wheel.



Product ID No.	Box/Ctn
93-020	3 / 30



POCKET SHEARS MULTI-TOOL

■ Ideal for camping, gardening, crafts and everyday household uses.

All metal components made of heat treated stainless steel for strength, durability and long wear. Blade of the shears has “Micro-Serrations” to gently hold while cutting. Shears fold into



the handle. Pocket shears has; soil knife/rope cutter, pruning saw, all-purpose knife, weeder and stripper. Carrying case included.

Product ID No.	Overall Length		Box/Ctn
	Inches	mm	
74-438	8-1/4	210	0 / 10

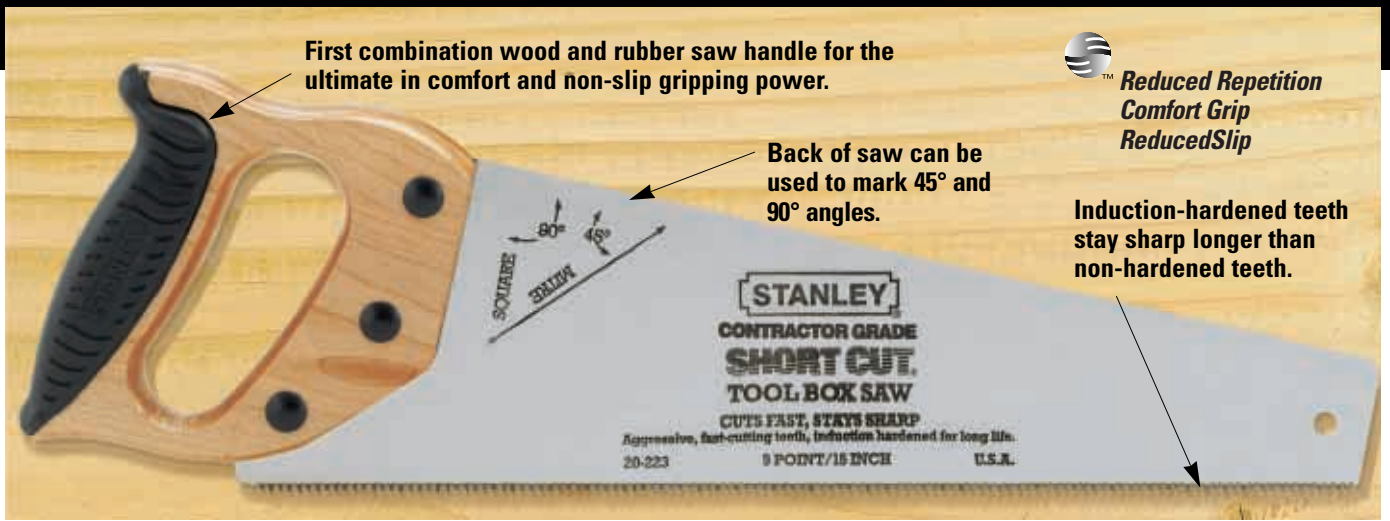

First combination wood and rubber saw handle for the ultimate in comfort and non-slip gripping power.

**Reduced Repetition
Comfort Grip
Reduced Slip**

Back of saw can be used to mark 45° and 90° angles.

Induction-hardened teeth stay sharp longer than non-hardened teeth.

CONTRACTOR GRADE™ CUSHION GRIP SHORT CUT® TOOL BOX SAW

■ The first ever combination wood and rubber create a saw handle that provides the ultimate in comfort and non-slip gripping power.



Aggressive 3-sided tooth design cuts wood 50% faster than conventional handsaws. 9 point induction-hardened teeth stay sharp longer than non-hardened teeth. Handle design allows for the back of the saw blade to be used for marking 45° and 90° angles. Total length of 18" fits conveniently in most tool boxes. Patent pending.

Product ID No.	Points per Inch	—Blade Length—		Box/Ctn
		Inches	mm	
20-223	9	15	380	0 / 4



CONTRACTOR GRADE™ SHORT CUT® TOOL BOX SAW

Aggressive 3-sided tooth design cuts wood 50% faster than conventional handsaws. Induction-hardened teeth stay sharp longer than non-hardened teeth. Handle design allows for the back of saw blade to be used for marking 45° and 90° angles. Total length of 18" fits conveniently in most tool boxes. Ideal for cutting plastic tubing. Hardwood handle.

Product ID No.	Points per Inch	—Blade Length—		Box/Ctn
		Inches	mm	
15-085	9	15	380	0 / 4
15-086	12	15	380	0 / 4



CONTRACTOR GRADE™ JET CUT® TOOL BOX SAW

Reduced Repetition

■ DynaGrip™ two textured handle gives you a non-slip grip for extra sawing power.

9 point induction hardened teeth stay sharp longer than non-hardened teeth. Aggressive 3-sided tooth design cuts wood 50% faster than conventional handsaws. Total length of 17-1/2" fits conveniently in most tool boxes.

Product ID No.	Points per Inch	—Blade Length—		Box/Ctn
		Inches	mm	
20-222	9	14	355	0 / 4



CONTRACTOR GRADE™ SHORT CUT® SAW

Aggressive 3-sided tooth design cuts wood 50% faster than conventional handsaws. Induction-hardened teeth stay sharp longer than non-hardened teeth. Hardwood handle has large opening for hand for comfort when wearing gloves. Ideal for cutting plastic tubing.

Product ID No.	Points per Inch	—Blade Length—		Box/Ctn
		Inches	mm	
15-087	8	20	508	0 / 2
15-088	12	20	508	0 / 2
20-065	12	26	660	0 / 2



SHORT CUT® TOOL BOX SAW

Compact design fits in a tool box. Aggressive 3-sided tooth design cuts 50% faster than conventional handsaws. Handle offers a square/mitre feature with 45° and 90° angles.

Product ID No.	Points per Inch	—Blade Length—		Box/Ctn
		Inches	mm	
15-334	9	15	380	4 / 4
15-534	12	15	380	4 / 4



AGGRESSIVE TOOTH DESIGN UTILIZES THREE CUTTING SURFACES.



SHORT CUT® HANDSAW

A revolutionary tooth design delivers clean cutting performance. Aggressive 3-sided tooth design cuts 50% faster than conventional handsaws. Teeth can be resharpened. Select hardwood handle provides greater comfort and control.



Product ID No.	Points per Inch	Blade Length Inches	Box/Ctn
15-335 Crosscut	8	20	4 / 4
15-336 Crosscut	8	24	2 / 2
15-535 Crosscut	12	20	2 / 2
15-536 Crosscut	12	24	0 / 2



MOLDED SAW PROTECTOR

Uniquely designed to fit most Stanley 20" panel saws or can be cut down to fit most 15" tool box saws.

The saw protector has molded carpenter's pencil pocket and inch measurements for quick reference marking. Molded of high density polyethylene, the saw protector will outlast normal cardboard sleeves and protect the blade and teeth from damage. Patent pending.

Product ID No.	Box/Ctn
20-330	0 / 6

SAW PROTECTOR WITH SHORT CUT® SAW (15-334)

We married our 15" Tool Box Saw (15-334) with the Saw Protector to provide an even greater value. Our aggressive 3-sided tooth design cuts wood 50% faster than conventional handsaws. Handle design allows for the back of the saw blade to be used for 45° and 90° angles.

Product ID No.	Box/Ctn
20-334	0 / 4



PRO HANDSAW

Traditionally designed saw has ground teeth which offer professional performance. Chrome nickel alloy steel blade holds its edge. Back striped blade. Extra wide stained hardwood handle designed for comfort and control.

Product ID No.	Points per Inch	Blade Length Inches	Box/Ctn
15-119 Rip Saw	5-1/2	26	2 / 2
15-118 Crosscut	8	26	2 / 2
15-110 Crosscut	10	26	2 / 2



HARD TOOTH™ HANDSAW

Special square and mitre feature built into saw handle enables user to draw 45° and 90° lines using the back of the blade. Induction hardened teeth preserve sharp cutting edges 3 to 5 times longer than standard teeth. Contoured sturdy polypropylene handle designed for comfort and control. Protective full-length sleeve.

Product ID No.	Points per Inch	Blade Length Inches	Box/Ctn
15-355	10	20	6 / 6
15-350	8	26	6 / 6



HANDSAW

Conventional teeth are machine set and sharpened for accurate cutting. High carbon steel blade hardened and tempered for sharpness and long life. Select hardwood handle for comfort and control. Protective full length sleeve.

Product ID No.	Points per Inch	Blade Length Inches	Box/Ctn
15-520 Crosscut	10	20	2 / 2
15-526 Crosscut	8	26	2 / 2
15-528 Crosscut	10	26	2 / 2



AGGRESSIVE TOOTH FAST CUTTING SAW

Fast cuts on both the push and pull stroke. Precision-ground; razor-sharp teeth. Handle molded for comfortable grip. Special handle design allows for back of saw to be used for marking 45° and 90° angles. 15" saw fits conveniently in tool box.

Product ID No.	Points per Inch	Blade Length Inches	Box/Ctn
15-579	9	15	0 / 4
15-580	9	20	0 / 2



CROSSCUT HANDSAW

Hardened, tempered polished steel blade for durability. Hardwood handle for comfort and control. Full length protective sleeve.

Product ID No.	Points per Inch	Blade Length Inches	Box/Ctn
15-300 Crosscut	8	26	6 / 6



726 HANDSAW

Handle offers a square/mitre feature with 45° and 90° angles. Contoured sturdy polypropylene handle designed for comfort and control. Handle ultrasonically welded to blade. Full length protective sleeve.

Product ID No.	Points per Inch	Blade Length Inches	Box/Ctn
15-726 Crosscut	8	26	6 / 6



GENERAL PURPOSE PANEL SAW

Excellent value for general household use. Machined set teeth. High carbon steel blade. Oil finished hardwood handle.

Product ID No.	Points per Inch	Blade Length Inches	Box/Ctn
15-775	8	20	6 / 6



TRADITIONAL SAW

Ground tooth design offers professional performance beyond standard filed teeth. Large comfortable traditionally shaped handle design.

Product ID No.	Points per Inch	Blade Length Inches	Box/Ctn
15-777	10	26	2 / 2



CONTRACTOR GRADE™ SHORT CUT® DRYWALL SAW

Aggressive 3-sided tooth design makes fast, smooth cuts in drywall. Induction-hardened teeth hold up against abrasive drywall materials. Hardwood handle for durability and comfort.



Product ID No.	Points per Inch	—Blade Length—		Box/Ctn
		Inches	mm	
15-025	8	15	380	0 / 2



DRYWALL SAW

Heavy duty, specially designed rounded tooth and gully prevents clogging. Teeth are sharpened and set.

Product ID No.	Points per Inch	—Blade Length—		Box/Ctn
		Inches	mm	
15-207	5-1/2	15	380	6 / 6



CONTRACTOR GRADE™ MINI UTILITY SHORT CUT® SAW

12 point induction-hardened teeth stay sharp longer than non-hardened teeth. Aggressive 3-sided tooth design cuts wood 50% faster than conventional handsaws. 10" blade is ideal for access in tight spaces and cutting a variety of materials such as plastic, pipe, particle board, and wood. Hardwood handle is contoured to fit the hand comfortably. Compact 15-1/2" overall length fits conveniently in most tool boxes.



IDEAL FOR ACCESS IN TIGHT SPACES AND CUTTING A VARIETY OF MATERIALS.

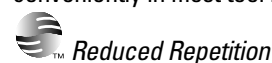

Product ID No.	Points per Inch	—Blade Length—		Box/Ctn
		Inches	mm	
20-221	12	10	254	0 / 6

CONTRACTOR GRADE™ COMPASS SAW

High grade tempered steel blade. Induction-hardened teeth stay sharp longer than non-hardened teeth. Teeth precision-set and sharpened for fast and smooth cutting. Hardwood handle for durability.

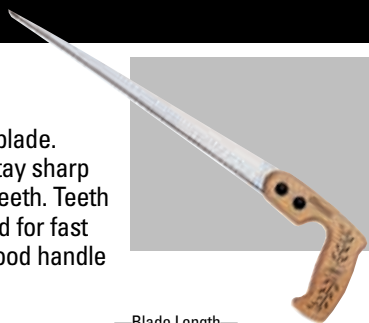

Product ID No.	Points per Inch	—Blade Length—		Box/Ctn
		Inches	mm	
15-100	8	12	305	0 / 6
15-101	8	14	355	0 / 6

HARD TOOTH™ COMPASS SAW

Induction hardened teeth preserve sharp cutting edge 3 to 5 times longer than standard teeth. For cutouts of curved shapes in wood, plywood, or plasterboard. Contoured handle for comfort. Protective sleeve.



Product ID No.	Points per Inch	—Blade Length—		Box/Ctn
		Inches	mm	
15-351	8	12	305	6 / 6

WOOD HANDLE COMPASS SAW

For cutting out curved shapes in wood, plasterboard or plywood. High grade tempered steel blades. Teeth precision set and sharpened for fast and smooth cutting.



Product ID No.	Points per Inch	—Blade Length—		Box/Ctn
		Inches	mm	
15-114	8	14	355	6 / 6
15-212	8	12	305	6 / 6
15-634	10	10	255	6 / 6

COMPASS SAW

Hardened, tempered steel blade with contoured comfortable handle.



Product ID No.	Points per Inch	—Blade Length—		Box/Ctn
		Inches	mm	
15-443	8	12	305	0 / 6



COPING SAW

Finest pro quality. Rich, walnut stained hardwood handle. Blade is highest grade high carbon steel—hardened and tempered to give clean, controllable cutting action.

Product ID No.	—Length—		—Frame Depth—		Box/Ctn
	Inches	mm	Inches	mm	
15-104	6-3/8	160	4-3/4	120	6 / 6
15-106	6-3/8	160	6-3/4	170	6 / 6

COPING SAW CARDED WITH 3 BLADES

Product ID No.	—Length—		—Frame Depth—		Box/Ctn
	Inches	mm	Inches	mm	
15-104A	6-3/8	160	4-3/4	120	6 / 6
15-106A	6-3/8	160	6-3/4	170	6 / 6

COPING SAW BLADES

Stanley® Tools proudly continues the tradition of



Trojan® Blades, known by generations for excellent quality. Over the years Trojan® coping saw blades have earned a fine reputation. That's because state-of-the-art manufacturing processes produce strong, yet flexible blades that simply last longer.

**Extra narrow blade for sharp surrounding cuts.*

Product ID No.	Size per Pitch	Box/Ctn
15-057*	6-1/2" x 20 TPI	10 / 50
15-058	6-1/2" x 10 TPI	10 / 50
15-059	6-1/2" x 20 TPI	10 / 50
15-060	6-1/2" x 32 TPI	10 / 50
15-061	6-1/2" x 15 TPI	10 / 50
20-003	6-1/2" x 24 TPI	10 / 50





4-WAY™ KEYHOLE SAW

4-way™ blade positioning cuts curves, circles and frets into places where an ordinary hacksaw cannot reach. Cuts wood, nails, metal lath, composition board, BX cable, conduit, etc. Lightweight, pistol grip handle fits hand. Complete with one wood cutting blade and one metal cutting blade.

Product ID No.	Box/Ctn
15-275	6 / 6

EXTRA BLADES FOR 4-WAY™ KEYHOLE SAW 15-275

2 blades per card.

Product ID No.	—Blade Length—		Box/Ctn
	Inches	mm	
15-276 Wood Blade	7-1/2	190	10 / 60
15-277 Metal Blade	7-1/2	190	10 / 60



KEYHOLE SAW

Turret head pistol grip handle. Quick change locking head holds blade in 8 positions. Furnished with 3 special purpose blades that are quickly and easily interchangeable. Positive chucking jaw locks blade—holds it rigid even under severe use. All metal construction.

Product ID No.	Box/Ctn
15-175 Wood, Metal, Drywall Blades	2 / 2

CONTRACTOR GRADE™ CUSHION GRIP WALLBOARD SAW

■ Ergonomically designed curved handle is cushioned for comfort and extended use.

Fully hardened, tempered blade is designed to be strong and durable. Teeth designed to cut fast and prevent clogging. Sharp tip for plunge cuts. Blade is epoxy-bonded to handle for a secure fit and long life.



Product ID No.	—Blade Length—		Box/Ctn
	Inches	mm	
15-556	6	152	6 / 36



15-206



15-764

WALLBOARD SAW

Designed especially for plasterboard. Make cutouts for electric outlets, etc. Self-starting point sharpened for plunge cuts. Blade is epoxy-bonded and ferruled to the stained wood handle, which holds the blade as much as three times longer than competitive blades, which are not epoxy bonded.

Product ID No.	—Blade Length—		Box/Ctn
	Inches	mm	
15-206	6	152	6 / 6

ECONOMY WALLBOARD SAW

Pointed blade for plunge cuts. Blade is epoxy bonded to handle for longer hold, unlike competitive blades. Oil finished hardwood handle is contoured for comfort. For all gypsum wallboard, sheetrock and plastic materials. Make cutouts for switches and outlets.

Product ID No.	—Blade Length—		Box/Ctn
	Inches	mm	
15-764	6	152	6 / 6



**CONTRACTOR GRADE™
SHORT CUT® BACK SAW**



Aggressive 3-sided tooth design cuts wood 50% faster than conventional handsaws. Induction-hardened teeth stay sharp longer than non-hardened teeth. A unique mitre saw with the Short Cut® feature and hardened tooth advantage. Hardwood handle for durability. Ideal for cutting plastic tubing.

Product ID No.	Points per Inches	Width Under Back Inches	mm	—Blade Length— Inches mm		Box/Ctn
15-672	12	3-5/16	84	12	305	0 / 2
15-673	12	3-5/16	84	14	355	0 / 2



HARD TOOTH™ BACK SAW

High quality steel, hardened and tempered for strength and durability. Solid plastic contoured handle with textured finger grips for better control. Induction hardened teeth preserve sharp cutting edge.

Product ID No.	Points per Inches	Width Under Back Inches	mm	—Blade Length— Inches mm		Box/Ctn
15-352	13	3-3/16	81	14	355	6 / 6



BACK/MITRE SAW

For general use for mitre box and cabinet work. Stiff blade with heavy steel back for strength. Solid hardwood handle for long life. Aluminum handle hardware.

Product ID No.	Points per Inches	Width Under Back Inches	mm	—Blade Length— Inches mm		Box/Ctn
15-635	13	3-3/16	81	12	305	6 / 6
15-636	13	3-3/16	81	14	355	6 / 6
15-637	13	3-3/16	81	16	405	6 / 6



BACK SAW

Hardened and tempered steel for durability with contoured, molded handle for comfort.

Product ID No.	Points per Inches	Width Under Back Inches	mm	—Blade Length— Inches mm		Box/Ctn
15-459	13	3-3/16	81	12	305	0 / 6
15-509	13	3-3/16	81	14	355	0 / 6



**CONTRACTOR GRADE™
CUSHION GRIP MULTI SAW**

Ergonomically designed curved handle is cushioned for comfort and prolonged use. Accepts standard reciprocating blade or hacksaw blade. Ideal for close quarter sawing. Large tension nut makes securing the blade quick and easy.



Product ID No.	Length Inches	Box/Ctn
20-220	8 Closed	6 / 36

FOLDING POCKET SAW

Folds like a jack knife for safe, easy storage. Accepts standard sabre and reciprocating blades. Blade storage in handle.

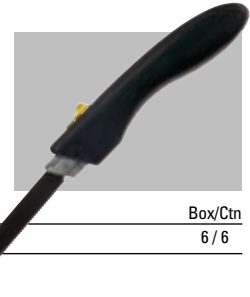

Product ID No.	Length Inches	Box/Ctn
15-333	8 Closed	6 / 6

**AGGRESSIVE TOOTH
FOLDING POCKET SAW**

Fast cuts for home, garden, hiking and camping. High visibility green is easy to find in a tool box, garage or back pack. Uses standard sabre and reciprocating blades. Store extra blades in handle.

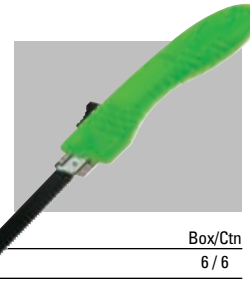

Product ID No.	Length Inches	Box/Ctn
15-666	8 Closed	6 / 6

REPLACEMENT BLADE

Product ID No.	Blades per Card	Teeth per Inch	Size of Pitch	Blade Length Inches	Box/Ctn
15-744	1	10	10 TPI x 6"	6	10 / 50

MULTI SAW

Accepts all reciprocating and hacksaw blades. Great tool for gaining access into restricted areas. Contoured handle is comfortable and provides maximum control. High visibility green colored handle for visibility.

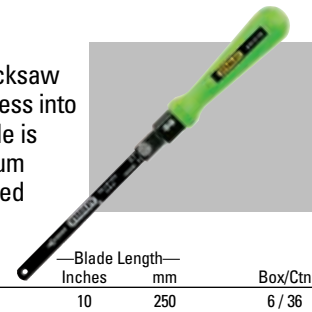

Product ID No.	—Blade Length— Inches mm		Box/Ctn
20-219	10	250	6 / 36

**CONTRACTOR GRADE™
FLUSH CUT SAW**

■ Flexible blade cuts plugs or dowels flush.

23 pt. blade cuts quickly and cleanly on the pull stroke. Double sided blade for convenient cutting to the left or right. Comfortable handle contoured for maximum control. Excellent for trimming through tenons or lap joints.



Product ID No.	Points per Inch	—Blade Length— Inches mm		Box/Ctn
20-331	23	4-3/4	119	6 / 36



NEST-OF-SAWS

Three versatile, interchangeable blades in a comfortable molded handle. Perfect for curves, circles and trim work. Includes a fast-cutting 12" Short Cut® finishing blade which can be used to cut molding, PVC pipe and even green or wet wood.

Product ID No.	Number of Blades	Box/Ctn
15-090	3	6 / 6

NEST-OF-SAW REPLACEMENT BLADE

Product ID No.	Box/Ctn
15-092 10" Compass Saw Blade	10 / 60



SHORT CUT® PRUNING SAW

Three-sided aggressive tooth design cuts on both the push and pull stroke. Pistol grip handle has safety notch to ensure a non-slip grip. Comfortable hardwood handle for durability. 8 point, 10" blade is ideal for camping, pruning and cutting firewood.

Product ID No.	Points per Inch	Blade Length Inches	Box/Ctn
20-230	8	10	0 / 6

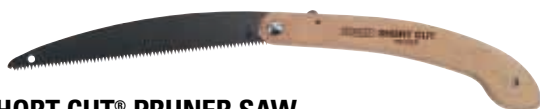

SHORT CUT® PRUNER SAW

Fast, efficient cuts in green and wet wood. Razor sharp Short Cut® teeth cut on both push and pull stroke. Comfortable hardwood handle is curved for improved cutting leverage. Has flared end for safety and control. Folds closed for safe, convenient storage.

Product ID No.	Points per Inch	—Blade Length—		Box/Ctn
		Inches	mm	
15-800	8	10	250	0 / 3



CALIFORNIA CURVED PRUNING SAW

This saw has a narrow blade made of finely tempered steel with reverse teeth to permit sawing on the pull stroke. Teeth are accurately sharpened and set. Solid hardwood handle with lacquered finish for long life.

Product ID No.	Points per Inch	—Blade Length—		Box/Ctn
		Inches	mm	
15-372	6-1/2	14	355	6 / 6

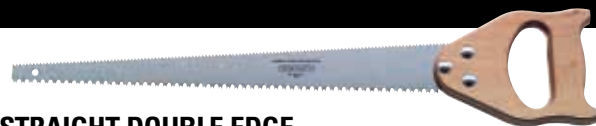

STRAIGHT DOUBLE EDGE PRUNING SAW

Good quality, specially hardened and tempered blade. One edge has sharp, crosscut teeth, 8 points to the inch for finish stroke and barking; other edge has coarse "Champion" teeth for easy sawing in green wood. Natural hardwood handle with lacquer finish.

Product ID No.	Points per Inch	—Blade Length—		Box/Ctn
		Inches	mm	
15-374	8	18	455	6 / 6



CONTRACTOR GRADE™ DOVETAIL SAW

Cuts a true, smooth and narrow kerf. Comfortably designed hardwood handle provides positive grip. Fine cutting, 15 point blade.

Product ID No.	Points per Inch	—Blade Length—		Box/Ctn
		Inches	mm	
15-022	15	10	255	2 / 2

DOVETAIL SAW

Fine cutting, 15 point blade cuts a true, smooth and narrow kerf. Oil finished hardwood handle contoured for comfort. Rigid steel back keeps 2" wide blade stiff for greater accuracy.

Product ID No.	Points per Inch	Blade Width Inches	—Blade Length—		Box/Ctn
			Inches	mm	
15-739	15	2	10	250	4 / 4

FINE WOODWORKING BACK / DOVETAIL SAW WITH REVERSIBLE HANDLE

The offset handle for flush cutting and the ability to reverse the handle for right hand or left hand cuts makes this saw one of our most versatile products. The 3" wide blade has stiff steel back for true cuts.

Product ID No.	Length Inches	Blade Width Inches	Box/Ctn
15-252	10	3	4 / 40



UNIQUE MULTI-CROSS FUNCTIONAL SAW WHICH CAN BE USED AS A BOW SAW OR A HACKSAW.



BOW SAW/HACKSAW

■ A unique multi-cross functional saw which can be used as a bow saw or a hacksaw.

When used with a hacksaw blade this saw is designed to cut wide diameter material. When used with a bow saw blade this saw allows you to cut large diameter plastic pipe, wood and tree branches.



Product ID No.	—Blade Length—		Box/Ctn
	Inches	mm	
20-447	12	305	0 / 6



BOW SAW

Tension lever provides clearance to protect fingers when changing blades. Blade fastened with rivets that remain attached during blade changes. Frames manufactured from welded tubing for added strength and durability. Saw blades are made with high-quality, cold-rolled steel. Teeth are hardened for long life and added durability.

Product ID No.	—Blade Length—		Box/Ctn
	Inches	mm	
15-449	21	535	0 / 12
15-451	24	610	0 / 12
15-453	30	760	0 / 12



BOW SAW BLADES

Saw blades made from high-quality, cold-rolled steel. Teeth are hardened for long life and added durability.

Product ID No.	—Blade Length—		Box/Ctn
	Inches	mm	
20-437 For 20-447	12	305	0 / 200
15-446	24	610	0 / 200
15-448	30	760	0 / 200



CULINARY SAW

■ 9 point stainless steel blade won't rust. Cleans easily for sanitation. Durable hardwood handle is contoured for comfortable grip. Solid nickel coated steel frame provides a positive cut. Depth of cut 5-3/4".

Product ID No.	—Length in Inches—		Depth Frame Inches	Box/Ctn
	O/A	Blade		
20-100	27	20-1/2	5-3/4	0 / 2

CULINARY SAW BLADE

9 point stainless steel blade resists rust. Cleans easily for sanitation. Blade Length 20-1/2".

Product ID No.	Points per Inch	Blade Length Inches	Box/Ctn



CONTRACTOR GRADE™ METAL MINI-HACK™ UTILITY SAW

Cast aluminum handle is lightweight — but built for durability. Comfortable handle design. Supplied with a high performance, 10" bi-metal blade.

Product ID No.	—Blade Length—		Box/Ctn
	Inches	mm	
15-809	10	254	6 / 36



MINI-HACK™ SAW

Uses regular hacksaw blades. For hard-to-get-at places and light-duty cutting. Durable molded frame offers maximum hand comfort.

Product ID No.	Length w/o Blade		Box/Ctn
	Inches	mm	
15-210	8-3/4	220	6 / 36

CONTRACTOR GRADE™ HIGH TENSION HACKSAW

■ Ergonomically designed bi-material frame and grip.

Thumb grip is designed to give better control. Fiberglass covered core absorbs more shock. Single action blade tensioning device is easy to use. Heavy duty steel reinforced core for increased cutting speed.



Product ID No.	—Depth of Throat—		—Blade Length—		Box/Ctn
	Inches	mm	Inches	mm	
20-115	5	125	12	305	0 / 2

CONTRACTOR GRADE™ HIGH TENSION HACKSAW

Rugged design for heavy-duty use. Fully adjustable tension—holds blade up to 32,000 p.s.i., which provides longer blade life and fast, accurate cuts. Blade storage in frame. Quick-release, blade-changing mechanism in handle, maintains tension setting. Tension guide on handle lever. Hacksaw or reciprocating blades extended out nose of frame can be locked into place for tight clearance work.



Product ID No.	—Depth of Throat—		—Blade Length—		Box/Ctn
	Inches	mm	Inches	mm	
15-113	3-7/8	98	12	305	2 / 12

HIGH TENSION-LOW PROFILE HACKSAW

■ Unique arc shape frame allows for cutting in tight, hard-to-reach areas.

Deep throat allows efficient cutting of large PVC pipes. Heavy duty cast aluminum I-beam frame for strength and durability. Blade angles on both 90° and 45° axis for measured cutting. High tension knob allows for easy blade tension adjustment. Ergonomically designed handle for comfortable use.



Product ID No.	—Depth of Throat—		—Blade Length—		Box/Ctn
	Inches	mm	Inches	cm	
20-001	4	102	12	30	0 / 4

HIGH TENSION HACKSAW

High tension frame provides up to 200 lbs. of blade tension for straighter cuts by reducing blade twisting and bending.

Strong rectangular tubular frame offers extra blade storage. Cast metal handle protects hands from work surface. Permanently mounted blade-anchor pins adjust to 8 cutting positions. Comes complete with high quality 12" bi-metal blade.



Product ID No.	—Depth of Throat—		—Blade Length—		Box/Ctn
	Inches	mm	Inches	mm	
15-120	4	100	12	305	2 / 12

TUBULAR FRAME HACKSAW

Heavy gauge tubular steel frame nickel plated—will not tarnish or rust—provides handy holding compartment for extra blades. Easy adjustment of frame for 10" (255 mm) and 12" (305 mm) blades. Blade can be faced in four directions. Rugged cast handle with guard designed to protect knuckles. Furnished with 10" (255 mm) standard carbon steel blade.



Product ID No.	—Depth of Throat—		—Blade Length—		Box/Ctn
	Inches	mm	Inches	mm	
15-408	3-7/8	98	10	255	2 / 12

RUBBER GRIP HACKSAW

Rigid steel frame with molded cushion grip. D-shape guard protects hand and knuckles. Adjustable frame.



Product ID No.	—Depth of Throat—		—Blade Length—		Box/Ctn
	Inches	mm	Inches	mm	
15-265	3-7/8	98	10	255	6 / 6

FIXED FRAME HACKSAW

Sturdy all metal frame. Easy blade loading. Full grip protects knuckles.



Product ID No.	—Depth of Throat—		—Blade Length—		Box/Ctn
	Inches	mm	Inches	mm	
15-285	3-1/2	88	10	255	6 / 6

ADJUSTABLE HACKSAW

Rugged plated steel frame. Fits 10" and 12" blades. Comfort pistol grip handle.



Product ID No.	—Depth of Throat—		—Blade Length—		Box/Ctn
	Inches	mm	Inches	mm	
15-565	2-3/4	70	10	255	6 / 6

FINE WOODWORKING QUICK RELEASE JUNIOR HACKSAW

Quick release hacksaw features a lever molded into the D-Grip handle for quick and easy blade changes and a deep throat for good work capacity. A spare blade is supplied with each hacksaw and extra replacement blades are available.



Product ID No.	—Depth of Throat—		—Blade Length—		Box/Ctn
	inches	mm	Inches	mm	
15-218	5-1/2	138	6	152	10 / 100
15-905 Replacement Blade			6	152	10 / 200

BI-METAL HACKSAW BLADES 15-600 SERIES

Made for the user who does not compromise performance. Stanley Bi-Metal blades combine the flexibility of carbon steel backs with the cutting performance of high speed steel.



Product ID No.	Blades per Card	Size per Pitch	—Blade Length—		Box/Ctn
			Inches	mm	
15-627	1	10" x 32 TPI	10	254	10 / 100
15-628	1	10" x 24 TPI	10	254	10 / 100
15-629	1	10" x 18 TPI	10	254	10 / 100
15-630	1	12" x 32 TPI	12	305	10 / 100
15-631	1	12" x 24 TPI	12	305	10 / 100
15-632	1	12" x 18 TPI	12	305	10 / 100
15-613	10	12" x 24 TPI	12	305	5 / 50

HACKSAW BLADES 15-800 SERIES

High speed steel blades cut most metals including unhardened tool steel and stainless.



Product ID No.	Packed	Size per Pitch	—Blade Length—		Box/Ctn
			Inches	mm	
15-802	100/Box	10" x 32 TPI	10	254	1 / 5
15-802A	1/Card	10" x 32 TPI	10	254	10 / 100
15-804	100/Box	10" x 24 TPI	10	254	1 / 5
15-804A	1/Card	10" x 24 TPI	10	254	10 / 100
15-808	100/Box	10" x 18 TPI	10	254	1 / 5
15-808A	1/Card	10" x 18 TPI	10	254	10 / 100
15-822	100/Box	12" x 32 TPI	12	305	1 / 5
15-822A	1/Card	12" x 32 TPI	12	305	10 / 100
15-824	100/Box	12" x 24 TPI	12	305	1 / 5
15-824A	1/Card	12" x 24 TPI	12	305	10 / 100
15-828	100/Box	12" x 18 TPI	12	305	1 / 5
15-828A	1/Card	12" x 18 TPI	12	305	10 / 100

HACKSAW BLADES 15-900 SERIES

High carbon steel blades cut mild steel, cast iron, aluminum, copper.



Product ID No.	Packed	Size per Pitch	—Blade Length—		Box/Ctn
			Inches	mm	
15-902	100/Box	10" x 32 TPI	10	254	1 / 5
15-902A	2/Card	10" x 32 TPI	10	254	10 / 100
15-904	100/Box	10" x 24 TPI	10	254	1 / 5
15-904A	2/Card	10" x 24 TPI	10	254	10 / 100
15-908	100/Box	10" x 18 TPI	10	254	1 / 5
15-908A	2/Card	10" x 18 TPI	10	254	10 / 100
15-922	100/Box	12" x 32 TPI	12	305	1 / 5
15-922A	2/Card	12" x 32 TPI	12	305	10 / 100
15-924	100/Box	12" x 24 TPI	12	305	1 / 5
15-924A	2/Card	12" x 24 TPI	12	305	10 / 100
15-926	10/Card	12" x 18 TPI	12	305	5 / 50
15-928	100/Box	12" x 18 TPI	12	305	1 / 5
15-928A	2/Card	12" x 18 TPI	12	305	10 / 100
15-939	10/Card	12" x 24 TPI	12	305	5 / 50
15-955	10/Card	12" x 32 TPI	12	305	5 / 50

CUTTING TOOLS

CARBIDE GRIT BLADES, HACKSAW BLADES

Tungsten carbide particles allow blade to cut on forward and reverse strokes. Makes thin straight cuts in ceramic, hardened steel, cast iron and masonry. Fits standard hacksaw frame.



Product ID No.	—Back Saw—		Box/Ctn
	Inches	mm	
15-412 Hacksaw Blade	12	305	10 / 100
15-410 Rod Saw	10	254	10 / 100



CARBIDE GRIT SABRE/JIG SAW BLADES

Tungsten carbide particles cut ceramic tile, plastic, slate, sheet metal (18 gauge) and more. 1-1/4" universal shank fits most sabre/jig saws.

Product ID No.	Blades per Card	Size Application	—Back Saw—		Box/Ctn
			Inches	mm	
15-427	1	Fine Cuts	2-7/8	73	10 / 50
15-428	1	Rough Cuts	2-7/8	73	10 / 50

SCROLL SAW BLADES

Product ID No.	Blades per Card	Size per Pitch	Box/Ctn

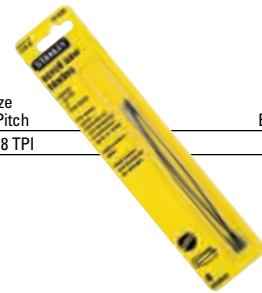

SAW SET

Saw set for setting teeth on conventional hand, back and panel saws, for both crosscut and rip. Unique magnifying lens over setting area for better visibility. Easy dial-adjustment knob for setting saws with 4 to 12 teeth per inch. Sturdy contoured pistol grip design.



Product ID No.	Box/Ctn
15-640	1 / 6

HEAVY DUTY MANDREL / HOLE SAW

Heavy duty mandrel with 1/4" shank.



Product ID No.	Shank in Inches	Fits Hole Saw Size	Box/Ctn
		Inches	
15-779	1/4	1-1/4 to 1-1/3	5 / 30



15-422

15-774

HOLE SAW 15-400 SERIES

Cuts clean round holes in ceramics, plastics, fiberglass, sheet metal up to 18 gauge.

Product ID No.	—Fits Mandrel—		Size in Inches	Box/Ctn
	5/16"	1/4"		
15-422 Carbide Grit	—	15-779	1-1/4	6 / 24

HOLE SAW STARTER SET

Makes clean round cuts in wood, composition board, plastics and soft metals. Can be used in portable electric drill, drill press and lathes.

Product ID No.	Set Contains:	Box/Ctn
15-774	1/4", 1-1/4", 1-1/2", 2", 2-1/8", Mandrels	5 / 30



CLAMPING MITRE BOX

■ Uniquely designed honeycomb base and cam pins secure work for accurate cuts.

Built-in measuring scale. Cuts miters on 45° and 90°, face angle 45° and all new 22-1/2° angles for octagon.

Product ID No.	—Back Saw—		Box/Ctn
	Inches	mm	
20-112	—	—	1 / 6
20-600 With Saw	14	350	1 / 6

MITRE BOX WITH SAW

Ideal for the do-it-yourselfer or as a second box for the pro. Cast aluminum frame construction with offset legs for stability. 4" depth capacity and patented, free floating saw guide allows larger boards to be cut with ease. Spring loaded wedge for quick angle settings. Adjustable index plate for maintaining angular accuracy. Saw thickness adjustment for added project flexibility. 11 preset cutting positions including settings for 4, 5, 6 and 8 sided figures. Cuts from 90° to 45° left and right. Contains board stop and stock guide.



Product ID No.	—Back Saw—		Box/Ctn
	Inches	mm	
19-035 With Saw	18 x 4	457 x 102	1 / 1

MITRE BOX

Rigid all aluminum construction for long life. Saw guide is easily adjusted. Simple wedging mechanism locks firmly at 8 of the most common cut angles. One wing screw adjustment allows the use of back or panel saws of different blade thicknesses. Base has recessed kerf slots to protect saw and bolt slots for bench mounting as well as holes to fasten wooden work board, if desired. Depth capacity of 2-1/4" below saw guide using recommended back saw.



Product ID No.	—Back Saw—		Box/Ctn
	Inches	mm	
19-114	—	—	1 / 1
19-614 With Saw	14 x 1/4	355 x 82	1 / 6

PLASTIC MITRE BOX

The mitre box for the occasional do-it-yourselfer. Lightweight, durable plastic body has contoured design with accuracy molded in. Slots for 90° and 45° cuts on left and right. Extended front lip butts up against work table to reduce slippage. Interior is open to allow cuttings to fall through. Counterbored holes in base allow mounting wooden board and/or fastening to workbench. Can be used with back or panel saw. Cut capacity for up to standard 2" x 4" lumber.



Product ID No.	—Back Saw—		Box/Ctn
	Inches	mm	
19-112	—	—	12 / 12
19-600 With Saw	14 x 3-1/4	355 x 83	1 / 6

Stanley finishing tools include files, rasps, scrapers, and exclusive Stanley Surform® planes and Surform® files. All are used for “surface forming”, shaving, planing, smoothing, filing and sanding wood, plastics, soft metals and other materials. The cutting blades of Surform® tools have a unique design akin to that of a cheese or vegetable grater. Rows and rows of protruding teeth alternate with holes in the blade to cut into the stock and allow the waste to pass through the blade. Because of this unique design, Surform® tools can shape and smooth materials quickly, easily, and precisely without clogging.

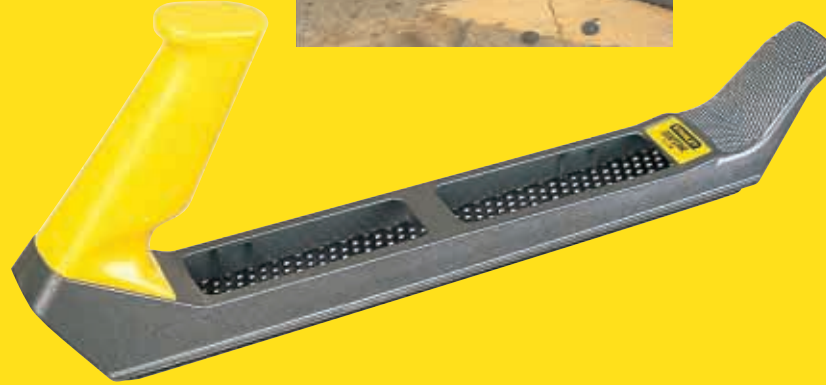

Surform® tools cut, shave, scrape, plane, form, file, smooth, sand and finish.



Putty knives have full tang steel blades, which are hardened, tempered and polished. The blade is permanently fastened to the handle with a full selection of blade styles.



STANLEY®

FINISHING TOOLS

Stanley® offers a variety of paint scrapers, window scrapers, glass and tile scrapers. Blades are made from high carbon steel for maximum sharpness.



Stanley® offers traditional files with high carbon file steel blades and impact resistant handles.



SURFORM® TOOLS CUT, SHAVE, SCRAPE, PLANE, FORM, FILE, SMOOTH, SAND AND FINISH.



IDEAL FOR END-GRAIN WORK, AUTOMOTIVE BODYWORK REPAIR AND SHEETROCKING.

SURFORM® PLANE

Resilient enough for use on materials that would destroy a traditional bench plane blade. Manufactured with a metallic grey, die-cast alloy body. Handle made of tough polypropylene. Fitted with a replaceable (10"/250mm) standard cut blade.



Product ID No.	Width		O/A Length in Inches	Box/Ctn
	Inches	mm		
21-296	1-5/8	41	12-1/2	0 / 4

SURFORM® POCKET PLANE

Neat, one handed tool. Ideal for end-grain work and sheetrocking. Manufactured with a metallic grey, die-cast alloy body. Includes a thumb screw locking mechanism for quick blade replacement. Fitted with a replaceable (5-1/2"/140mm) fine cut blade.



Product ID No.	Width		O/A Length in Inches	Box/Ctn
	Inches	mm		
21-399	1-5/8	41	6	4 / 24

SURFORM® FLAT FILE

More versatile and comfortable to use than a traditional file. Manufactured with a metallic grey, die-cast alloy body. Handle made of tough polypropylene. Fitted with a replaceable (10"/250mm) standard cut blade.



Product ID No.	Width		O/A Length in Inches	Box/Ctn
	Inches	mm		
21-295	1-5/8	41	17-3/8	6 / 6

SURFORM® SHAVER

Compact and effective lightweight polypropylene molded body. Curved blade for increased stock removal. Works on the pull stroke. Simple, click-on blade replacement.

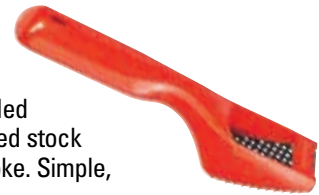

Product ID No.	O/A Length in Inches	Box/Ctn
21-115	7-1/4	6 / 36

SURFORM® ROUND FILE

Especially useful for enlarging holes and smoothing curved surfaces. Ideal for pipe fittings in MDF or chipboard. Manufactured with a tough polypropylene handle and thumb support. Fitted with a replaceable (10"/250mm) round blade.



Product ID No.	O/A Length in Inches	Box/Ctn
21-297	15-3/4	6 / 24

SURFORM® STANDARD CUT REPLACEMENT BLADE

10"/250mm. All purpose blade — use on wood, vinyl, plaster, thermalite, fiberglass and linoleum. Standard cut blade features teeth flush to the blade edge for working into edges.

21-293



SURFORM® FINE CUT REPLACEMENT BLADE

10"/250mm. Designed to produce a fine finish on hard woods, end grains, ceramics and plaster.

21-393

SURFORM® FINE CUT REPLACEMENT BLADE

5-1/2"/140mm. Fine cut blade for finishing work and end grain.

21-398

Product ID No.	Fits Tools	—Overall Length— Inches mm	Width in Inches	Cut	Box/Ctn
21-293	21-295, 21-296, 21-285	10 250	1-5/8	Regular	6 / 36
21-393	21-295, 21-296	10 250	1-5/8	Fine	6 / 72
21-398	21-399	5-1/2 140	1-5/8	Fine	6 / 36

SURFORM® HALF ROUND REPLACEMENT BLADE

Half round convex blade for faster stock removal and shaping curved surfaces. Ideal for work on fiberglass and removing filler (for cars and boats).

21-299



SURFORM® ROUND REPLACEMENT BLADE

10"/250mm. Round blade for enlarging holes and smoothing curved surfaces.







21-291

SURFORM® SHAVER REPLACEMENT BLADE

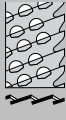
2-1/2"/63mm. Curved blade for fast stock removal. Works on the pull stroke.

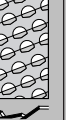
21-515

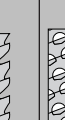
Product ID No.	Fits Tools	—Overall Length— Inches mm	Width in Inches	Cut	Box/Ctn
21-299	21-295, 21-296	10 250	1-1/2	Regular	6 / 36
21-291	21-297	10 250	1-1/2	Regular	6 / 36
21-515	21-115	2-1/2 63	1-5/8	Regular	6 / 36

Surform® Tool and Blade Chart						
	Standard Cut 21-293	Fine Cut 21-393	Half Round 21-299	Round 21-291	Fine Cut 21-398	Curved 21-515
Hardwood	▲	▲	▲	▲	▲	▲
Softwoods	▲	▲	▲	▲	▲	▲
End Grain		▲			▲	
Chipboard	▲		▲	▲		▲
Plywood	▲		▲	▲		▲
Blockboard	▲		▲	▲		▲
Vinyl	▲	▲	▲	▲	▲	▲
Rubber	▲		▲	▲		▲
Plaster	▲	▲	▲	▲	▲	▲
Thermalite	▲		▲	▲		▲
Chalk	▲		▲	▲		▲
Fiberglass	▲		▲	▲		▲
Brass		▲			▲	
Lead		▲			▲	▲
Aluminum		▲			▲	
Copper		▲			▲	
Mild Steel						
Plastic Laminates						▲
Plastic Fillers			▲		▲	▲
Nylon	▲		▲	▲		▲
Linoleum	▲		▲	▲		▲
Ceramics		▲			▲	
Fits Tool(s)		21-295 21-296		21-297	21-399	21-115

MILL BASTARD FILE



For general purpose use; sharpening, smoothing and polishing. Blades manufactured from high carbon file steel. Each file comes with its own high impact-resistant molded handle with convenient hang hole.

Product ID No.	Length in Inches	Box/Ctn
22-006	6	6 / 36
22-008	8	6 / 36
22-010	10	6 / 36

HALF ROUND BASTARD FILE



Used for enlarging round and square holes and trimming burrs from pipe. Blades manufactured from high carbon file steel. Each file comes with its own high impact-resistant molded handle with convenient hang hole.

Product ID No.	Length in Inches	Box/Ctn
22-038	8	6 / 36

4-WAY™ RASP



For use on woods and plastics. Four different cutting surfaces. One side offers a flat rasp and double cut file. The other side offers a half round rasp and double cut file. Blades manufactured from high carbon file steel. Each file comes with its own high impact-resistant molded handle with convenient hang hole.

Product ID No.	Length in Inches	Box/Ctn
22-100	8	6 / 36

4 PIECE FILE SET

Versatile, the right shape for all filing needs. Four popular shapes, No. 6. Mill Bastard, No. 6 Slim Taper, No. 6 Round Bastard, 4-Way™ file. Long lasting, manufactured from hardened tool steel.



Product ID No.	Contents	Box/Ctn
22-004	6" Mill Bastard 6" Round Bastard 6" Slim Taper 4-Way™ File	6 / 6

SHORT CUT® SAW SHARPENING KIT

Designed for reshaping Stanley® Aggressive Tooth Short Cut® Saws. Triangular file with safe edge to use with file guide. File alone can be used on conventional saws. Sharpening instructions on back of card.



Product ID No.	Box/Ctn
22-434	4 / 24

NYLON HANDLE KNIVES

Full tang steel blade is hardened, tempered and polished. Permanently fastened to shatter resistant nylon handle.



A. PUTTY KNIFE

Available with stiff blade, full flexible taper ground blade, or chisel edge blade.

Product ID No.	Blade Type	—Blade Width—		Box/Ctn
		Inches	mm	
28-140	Stiff	1-1/4	32	5 / 50
28-240	Flexible	1-1/4	32	5 / 50
28-141	Stiff	1-1/2	38	5 / 50
28-241	Flexible	1-1/2	38	5 / 50
28-142	Stiff	2	51	5 / 50
28-242	Flexible	2	51	5 / 50

B. SCRAPER

Available with stiff blade or full flexible taper ground blade.

Product ID No.	Blade Type	—Blade Width—		Box/Ctn
		Inches	mm	
28-139	Stiff	3	76	5 / 50

C. JOINT KNIFE

Product ID No.	Blade Type	—Blade Width—		Box/Ctn
		Inches	mm	
28-244	Flexible	4	100	5 / 50
28-246	Flexible	6	152	5 / 50

WOOD HANDLE KNIVES

Full tang high carbon steel blade is hardened, tempered, taper ground and polished. Permanently fastened to hardwood handle.

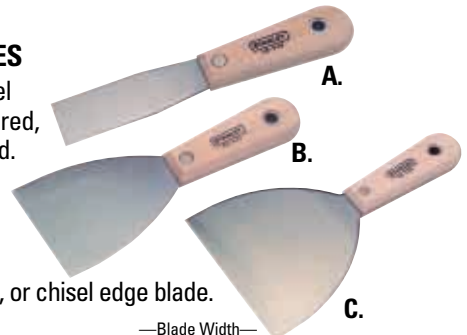

A. PUTTY KNIFE

Available with stiff, flexible, or chisel edge blade.

Product ID No.	Type	—Blade Width—		Box/Ctn
		Inches	mm	
28-540	Flexible	1-1/4	32	5 / 50
28-541	Stiff	1-1/4	32	5 / 50
28-542	Chisel	1-1/4	32	5 / 50

B. SCRAPER

Available with stiff or flexible blade.

Product ID No.	Type	—Blade Width—		Box/Ctn
		Inches	mm	
28-539	Flexible	3	76	5 / 50
28-543	Stiff	3	76	5 / 50

C. JOINT KNIFE

Product ID No.	Type	—Blade Width—		Box/Ctn
		Inches	mm	
28-538	Flexible	5	127	5 / 50
28-546	Flexible	6	152	5 / 50

POLYPROPYLENE HANDLE SCRAPER

Tempered steel blade securely fastened to polypropylene handle with three brass grommets. Clear coated blade resists rust.



Product ID No.	Type	—Blade Width—		Box/Ctn
		Inches	mm	
28-703	Stiff	3	76	5 / 50
28-713	Flexible	3	76	5 / 50

4-EDGE PAINT SCRAPER

Lightweight molded polypropylene paint scraper with curved handle. Designed for long life and comfort. Steel core grip knobs are ideal for light duty nail setting. Comes with four-edge blade.



Product ID No.	Handle Size In Inches	Blade Type	—Blade Width—		Box/Ctn
			Inches	mm	
28-612	12	4-Edge	2-1/2	64	5 / 5

4-EDGE SCRAPER REPLACEMENT BLADE

High carbon steel to maintain maximum sharpness for the life of the blade. Four-edge blade has two corrugated edges for rough scraping and two smooth edges for fine scraping.

Product ID No.	Fits Tools	—Blade Width—		Box/Ctn
		Inches	mm	
28-634	28-609, 28-612	2-1/2	64	5 / 25

2-EDGE PAINT SCRAPER

Lightweight molded polypropylene contoured paint scrapers. Designed for long life and comfort. Comes with two-edge blade.



Product ID No.	Handle Size In Inches	Blade Type	—Blade Width—		Box/Ctn
			Inches	mm	
28-616	6	2-Edge	1	25	5 / 30
28-617	7	2-Edge	1-1/2	38	5 / 30
28-619	9	2-Edge	2-1/2	64	5 / 30

2-EDGE SCRAPER REPLACEMENT BLADE

High carbon steel to maintain maximum sharpness for the life of the blade. Two smooth edges ideal for fine scraping.

Product ID No.	Fits Tools	—Blade Width—		Box/Ctn
		Inches	mm	
28-631	28-616	1	25	5 / 50
28-290	28-291, 28-617	1-1/2	38	5 / 50
28-292	28-293, 28-622, 28-619	2-1/2	64	5 / 50

BURN-OFF SCRAPER

Heavy duty steel blade bends at a 20° angle for easy paint removal.



Product ID No.	Blade Type	—Blade Width—		Box/Ctn
		Inches	mm	
28-170	Bent	3	76	5 / 50

SCRAPER

Quality tempered steel blade with accurately ground bevel edge removes both paint and wallpaper. Full size hardwood handle with lacquer finish.



Product ID No.	—Blade Length—		—Blade Width—		Box/Ctn
	Inches	mm	Inches	mm	
28-189	3-13/16	97	3-1/2	89	5 / 50

REFINISHING HAND SCRAPER

Selection of steel and heat treatment of this blade make it a superior tool. Thickness — .037".



Product ID No.	—Overall Length—		—Width—		Box/Ctn
	Inches	mm	Inches	mm	
28-035	5	127	3	76	5 / 50

RETRACTABLE RAZOR BLADE SCRAPER

Removes paint, glue, putty or adhesives from glass, tile, walls, floors or other smooth surfaces. Blade retracts for safe storage. Uses standard single edge razor blades. Comes with 5 blades.



Product ID No.	—Overall Length—		Box/Ctn
	Inches	mm	
28-500	3-3/4	95	10 / 100

HIGH VISIBILITY MINI BLADE SCRAPER

Lightweight and economical plastic razor blade scraper in assorted high visibility colors. Blade reverses for safe storage. Uses standard single edge razor blade. Great for scraping in hard-to-reach places.



Product ID No.	—Overall Length—		Box/Ctn
	Inches	mm	
28-100	1-13/16	46	12 / 144

SINGLE EDGE RAZOR BLADES

Steel backed high carbon steel blade fits all standard razor blade tools. Replacement blades for 28-100 and 28-500 scrapers.



Product ID No.	Packed	Length in	Thickness	Box/Ctn
		Inches	in Inches	
28-510	10/Card	1-12	.009	10 / 100
11-516	100/Box	1-1/2	.009	0 / 50

WINDOW SCRAPER

Ideal for scraping paint from windows, mirrors, tiles and other flat surfaces. Furnished with one 11-921 utility blade.



Product ID No.	—Overall Length—		Box/Ctn
	Inches	mm	
28-593	7	178	4 / 24

GLASS AND TILE SCRAPER

4" wide blade to save time on large jobs. Used to remove paint and stickers from glass and tile. Replaceable blade. Rugged polypropylene construction resists most common paint thinners. Quick release blade change.



Product ID No.	Box/Ctn

4" SCRAPER BLADE



Product ID No.	Width	Box/Ctn
	in Inches	
28-597	4	10 / 200

From innovative locking tape measures to industrial long tapes, Stanley® measuring tools are recognized and used around the world. For 150 years, we've been building durable, accurate tape rules that meet the needs and demands of top pros and do-it-yourselfers alike. Today, Stanley offers tapes in a variety of styles and lengths — from 3' to 200' — with features like positive blade lock, automatic return, Mylar* coating and impact-resistant cases. No wonder we're the undisputed leader in measuring tools. At Stanley, we do whatever it takes to measure up to your expectations.

*DuPont polyester film.



Stanley® fiberglass long tapes have more fiberglass strands which means less stretch and better accuracy. The blade is printed on both sides with multiple formats (fractional/decimal or Metric English).



BADGE OF THE PROFESSIONAL

The design of the POWERLOCK® Tape Rule case is a registered trademark of The Stanley Works.

STANLEY

MEASURING TOOLS



Stanley® tape rules offer heavy-duty steel or fiberglass blades designed for exceptional standout and readability. Many tapes have markings for laying out studs on 16" centers or other specialized markings.



Stanley® Contractor Grade™ tape rules feature highly durable, impact-resistant cases and "blanket wrap" Mylar* coatings that extend blade life up to ten times longer.

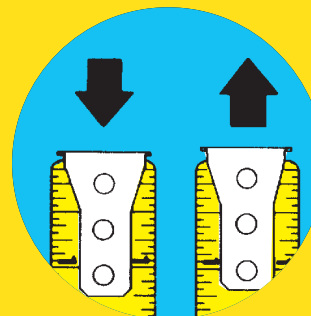

TRU-ZERO FEATURE
For inside or outside measurements, hook slides automatically to allow for its own thickness.

*DuPont Polyester Film.



Exclusive cushion grip for comfortable, non-slip grip and impact resistance!

 **Comfort Grip
Reduced Slip**

**CONTRACTOR GRADE™
MAXSTEEL™ TAPE RULES**

■ 25% thicker blade for the longest standout available up to 9 feet.

Exclusive cushion grip built into the case for comfortable non-slip grip and impact resistance. Massive new bumper designed for increased hook life. Heavier and stronger spring for extra long life and “smooth-as-silk” blade recoil. Three rivet, corrosion-resistant hook moves to allow accurate inside and outside measurements. Improved blade readability with high contrast color — easy to read in all light conditions. Top forward blade lock design makes it easier to lock and unlock the blade. Impact-resistant, safety-yellow case. Heavy-duty Mylar* “blanket-wrap” coating extends blade life up to ten times longer!



Product ID No.	Blade Length		Blade Width Inches	Box/Ctn
	Feet	Meters		
33-691	12	3	5/8	6 / 30
33-692	16	5	3/4	6 / 30
33-599†	25	7.5	1	4 / 24
33-600†	30	9	1	4 / 24

†25% thicker blade up to 9' standout, all others 13% thicker blade.

Metric

Product ID No.	—Blade Length—		Blade Width Inches	Box/Ctn
	Feet	Meters		
33-589	10	3	5/8	6 / 30
33-590	—	3	5/8	6 / 30
33-695	16	5	3/4	6 / 30
33-696	—	5	3/4	6 / 30
33-591	25	7.5	1	4 / 24
33-224	26	8	1	4 / 24
33-225	—	8	1	4 / 24
33-605	33	10	1	4 / 24
33-606	—	10	1	4 / 24
33-603	33	10	1	4 / 24
33-604	—	10	1	4 / 24

**CONTRACTOR GRADE™
HEAVY DUTY POWERLOCK® TAPE RULES**

13% thicker blade for longer standout up to 8 feet. Heavier and stronger spring for extra long life and “smooth-as-silk” blade recoil. Three rivet corrosion-resistant hook moves to allow accurate inside and outside measurements.

Improved blade readability with high contrast color — easy to read in all light conditions. Impact-resistant, safety-yellow case. Heavy-duty Mylar* “blanket-wrap” coating extends blade life up to ten times longer!



Product ID No.	Blade Length		Blade Width Inches	Box/Ctn
	Feet	Meters		
33-117	16	5	3/4	6 / 36
33-446	16	5	1	4 / 24
33-445	25	7.5	1	4 / 24
33-447	30	9	1	4 / 24
33-973	33	9.9	1	4 / 24

Metric

Product ID No.	—Blade Length—		Blade Width Inches	Box/Ctn
	Feet	Meters		
33-316	16	5	3/4	6 / 36
33-416	16	5	1	4 / 24
33-525	25	7.5	1	4 / 24
33-354	—	8	1	4 / 24
33-355	—	8	1	4 / 24

**CONTRACTOR GRADE™
HEAVY DUTY POWERLOCK® TAPE RULES WITH METAL CASE**

Extra strong, cast-metal case. 12' tape length. Heavy-duty Mylar* “blanket-wrap” coating extends blade life up to ten times longer. Two rivet, corrosion-resistant hook.



Product ID No.	—Blade Length—		Blade Width Inches	Box/Ctn
	Feet	Meters		
33-512	12	3.7	1/2	6 / 36
33-272	12	3.7	1/2	6 / 36

*DuPont Polyester Film.

CONTRACTOR GRADE™

HEAVY DUTY POWERSTOP® TAPE RULES

Mechanical bumper system helps reduce hook breakage. Heavier and stronger spring for longer life. Three rivet, corrosion-resistant hook moves to allow accurate inside and outside measurements. High contrast color improves blade readability — easy to read in all light conditions. Impact-resistant, safety yellow case. Heavy-duty Mylar* “blanket-wrap” coating extends blade life up to ten times longer!



Product ID No.	—Blade Length—		Blade Width Inches	Box/Ctn
	Feet	Meters		
33-587	27	—	1	4 / 24

POWERLOCK® TAPE RULES — 1" WIDE BLADE

Mylar* coated for added durability. Heat treated spring for longer life. 16" and 19.2" stud center markings on blade for framing purposes. Easy reach blade remains rigid for 7'. Positive blade lock will not creep while taking measurements.



Product ID No.	Blade Feet	Blade Width		Box/Ctn
		Feet	Inches	
33-423	16	1	1	4 / 24
33-425	25	1	1	4 / 24
33-430	30	1	1	4 / 24
33-835	35	1	1	4 / 24

Metric

Product ID No.	—Blade Length—		Blade Width Inches	Box/Ctn
	Feet	Meters		
33-195 <i>cm graduation</i>	—	5	1	4 / 24
33-428 <i>cm graduation</i>	25	7.5	1	4 / 24
33-427 <i>cm graduation</i>	—	7.5	1	4 / 24
33-429 <i>mm graduation</i>	26	8	1	4 / 24
33-198 <i>cm graduation</i>	—	8	1	4 / 24
33-825 <i>mm graduation</i>	—	8	1	4 / 24
33-443 <i>cm graduation</i>	33	10	1	4 / 24
33-432 <i>mm graduation</i>	33	10	1	4 / 24
33-442 <i>cm graduation</i>	—	10	1	4 / 24
33-433 <i>mm graduation</i>	—	10	1	4 / 24



COMFORT GRIP POWERLOCK® TAPE RULE

Smaller size for easier grip. Mylar* coated blade extends blade life up to ten times longer.

Product ID No.	Blade Length		Blade Width Inches	Box/Ctn
	Feet	Inches		
33-699	25	1	1	4 / 24



POWERLOCK® TAPE RULES — 3/4" WIDE BLADE

Mylar* coated blade for added durability. Heat treated spring for longer life. Positive blade lock will not creep while taking measurements. Graduated in 16ths of an inch. Belt clip is fastened on back of case.

Product ID No.	Blade Length		Blade Width Inches	Box/Ctn
	Feet	Meters		
33-310	10	3	3/4	6 / 36
33-312	12	3.5	3/4	6 / 36
33-116	16	5	3/4	4 / 24
33-320	20	6	3/4	6 / 36

Metric

Product ID No.	—Blade Length—		Blade Width Inches	Box/Ctn
	Feet	Meters		
33-328 <i>cm graduation</i>	10	3	3/4	6 / 36
33-076 <i>cm graduation</i>	12	3.5	3/4	6 / 36
33-158 <i>cm graduation</i>	16	5	3/4	6 / 36
33-194 <i>cm graduation</i>	—	5	3/4	6 / 36
33-166 <i>mm graduation</i>	20	6	3/4	6 / 36
33-259 <i>mm graduation</i>	—	6	3/4	6 / 36

Engineer's Scale 10th and 100th of Feet

Product ID No.	Blade Length		Blade Width Inches	Box/Ctn
	Feet	Meters		
33-235 <i>10th and 100th of feet</i>	12	3.5	3/4	6 / 36



MASON'S POWERLOCK® TAPE RULE

Mylar* coated blade for added durability. Six scales in 16" modular for bricks, blocks, tile. Inch graduations on one edge, modular markings on other edge. Heat-treated spring for longer life. Positive blade lock will not creep while taking measurements.

Product ID No.	Blade Length		Blade Width Inches	Box/Ctn
	Feet	Meters		
33-570 <i>Modular Spacing</i>	10	3	3/4	6 / 36
33-575 <i>Brick Spacing</i>	10	3	3/4	6 / 36



*DuPont Polyester Film.



POWERLOCK® TAPE RULES — 1/2" WIDE BLADE

Mylar* coated blade for added durability. Heat treated spring for longer life. Positive blade lock will not creep while taking measurements. Graduated in 16ths of an inch. Belt clip is fastened on back of case.

Product ID No.	Blade Length Feet	Blade Width Inches	Box/Ctn
33-208	8	1/2	6 / 36
33-210	10	1/2	6 / 36
33-212	12	1/2	6 / 36

Metric

Product ID No.	—Blade Length— Feet Meters		Blade Width in Inches	Box/Ctn
33-238 <i>cm graduation</i>	—	3	1/2	6 / 36
33-203 <i>cm graduation</i>	10	3	1/2	6 / 36
33-180 <i>mm graduation</i>	—	3.5	1/2	6 / 36
33-215 <i>mm graduation</i>	12	3.5	1/2	6 / 36

Metric and Decimal Inch Graduations

For decimal measuring in automotive, aircraft, electronic, paper board and box manufacturing industries. Also has fraction graduations. First six inches of blade graduated in 32nds of an inch on upper edge and 50ths of an inch on lower edge. Balance of blade graduated in 16ths of an inch on upper edge and 10ths of an inch on lower edge. Mylar* coated blade for added durability. Heat-treated spring for longer life. Positive blade lock will not creep while taking measurements.



Product ID No.	—Blade Length— Feet Meters		Blade Width Inches	Box/Ctn
33-223	10	3	1/2	6 / 36



POWERLOCK® POCKET TAPE RULES — 1/4" WIDE BLADE

Scale on back of 33-115 will measure up to 3' diameters. Spring is heat treated for added durability and protected blade will withstand abrasion for long life. Slim, trim case is ideal for pocket or purse.

Product ID No.	—Blade Length— Feet Meters		Blade Width Inches	Box/Ctn
33-115 <i>Diameter Scale</i>	10	—	1/4	6 / 36
33-113	10	3	1/4	6 / 72



POWERLOCK® KEY TAPES

Blade is lacquer coated for added rust protection. Durable key ring feature, trim and lightweight for convenience. The “anywhere” rule – with you when you need it.

Product ID No.	—Blade Length— Feet Meters		Blade Width Inches	Box/Ctn
39-130	3	—	1/4	6 / 72
39-133 <i>cm graduation</i>	3	1	1/4	6 / 72
39-055 <i>cm graduation</i>	—	1	1/4	6 / 72



LEVERLOCK® TAPE RULES

Power return tape rule with automatic bottom lock for easy operation. Special Tru-Zero hook allows use of nail as pivot to draw circles and arcs. Three-riquet hook for longer life. Mylar* coated blade for added durability. Heat-treated spring for longer life. Belt clip is fastened on back of case.

Product ID No.	Blade Length Feet	Blade Width Inches	Box/Ctn
30-562	6	1/4	6 / 72
30-563	8	1/4	6 / 72
30-564	10	1/4	6 / 72
30-534	8	1/2	4 / 24
30-537	12	1/2	4 / 24
30-513	12	3/4	6 / 36
30-516	16	3/4	6 / 36
30-525	25	3/4	6 / 36
30-625	25	1	4 / 24

Metric

Product ID No.	—Blade Length— Feet Meters		Blade Width Inches	Box/Ctn
30-508 <i>mm graduation</i>	16	5	3/4	6 / 36
30-511 <i>mm graduation</i>	—	5	3/4	6 / 36
30-509 <i>mm graduation</i>	26	8	1	6 / 36
30-512 <i>mm graduation</i>	—	8	1	4 / 24

*DuPont Polyester Film.



HIGH VISIBILITY LEVERLOCK® TAPE RULES

High visibility color makes it easy to find in your tool box, cabinet or on the job. Power return tape rule with automatic bottom lock for easy operation. Mylar* coated blade for added durability. Heat-treated spring for longer life. Belt clip is fastened on back of case.

Product ID No.	Blade Length		Blade Width Inches	Color	Box/Ctn
	Feet	Meters			
30-434 * Key Tape	10	3	1/4	Green	6 / 72
30-984 *	8	2.4	1/2	Green	4 / 24
30-982 *	12	3.6	1/2	Green	6 / 36
30-986	16	4.8	3/4	Green	6 / 36
30-925	25	7.5	1	Green	4 / 24
30-985	25	7.5	1	Red	4 / 24
30-927	25	7.5	1	Orange	4 / 24
30-997	30	9	1	Green	4 / 24
30-995	30	9	1	Red	4 / 24
30-333	33	9.9	1	Red	4 / 24

Metric

Product ID No.	—Blade Length—		Blade Width Inches	Color	Box/Ctn
	Feet	Meters			
30-074 cm graduation	10	3	1/2	Orange	4 / 24
30-076 cm graduation	12	3.5	3/4	Orange	6 / 36
30-491 cm graduation	16	5	3/4	Orange	6 / 36
30-913 mm graduation	16	5	3/4	Green	6 / 36
30-951 mm graduation	—	5	3/4	Green	6 / 36
30-575 cm graduation	25	7.5	3/4	Orange	6 / 36
30-494 cm graduation	25	7.5	1	Orange	4 / 24
30-914 mm graduation	26	8	1	Green	4 / 24
30-957 mm graduation	—	8	1	Green	4 / 24
30-915 mm graduation	33	10	1	Green	4 / 24
30-958 mm graduation	—	10	1	Green	4 / 24

POCKET TAPE RULES

Slim, compact case. Yellow blade graduated in 16ths of an inch the entire length and 32nds of an inch for first six inches.

Product ID No.	Blade Length		Blade Width Inches	Box/Ctn
	Feet	Meters		
30-506	6	1.8	1/2	6 / 12
30-038	6	1.8	1/4	6 / 72
30-039	8	2.4	1/4	6 / 72
30-040	10	3.0	1/4	6 / 72



STANLEY® TAPE RULES

7' standout. Polymer coated blade for long life. Durable textured case for non-slip grip. High contrast blade for easy readability.

Product ID No.	—Blade Length—		Blade Width	Box/Ctn.
	feet	meter		
30-485	12	3.6	1/2	6 / 36
30-495	16	4.8	3/4	6 / 36
30-455	25	7.5	1	6 / 24

Metric

Product ID No.	—Blade Length—		Blade Width	Box/Ctn.
	feet	meter		
30-486 cm graduation	10	3	1/2	6 / 36
30-487 cm graduation	—	3	1/2	6 / 36
30-488 cm graduation	12	3.5	1/2	6 / 36
30-496 cm graduation	16	5	3/4	6 / 36
30-497 cm graduation	—	5	3/4	6 / 36
30-456 cm graduation	26	8	1	6 / 24
30-457 cm graduation	—	8	1	6 / 24
30-458 mm graduation	26	8	1	6 / 24
30-459 mm graduation	—	8	1	6 / 24



NUMERICAL READOUTS EVERY 1/8".

FRACTIONAL READ

Numerical readouts every 1/8". 7' standout. Polymer coated blade for long life. Durable textured case for non-slip grip. High contrast blade for easy readability.

Product ID No.	—Blade Length—		Blade Width	Box/Ctn.
	feet	meter		
30-454	25	7.5	1	4 / 24



**CONTRACTOR GRADE™
MAXSTEEL™ LONG TAPE**

■ 33% thicker blade for longer life.

Strong, corrosion resistant, Tru-Zero, two-position hook. Yellow tape with black markings for easy reading. Rugged metal case, will not rust. Contoured shape to fit the hand. Heavy duty Mylar* blanket-wrap coating extends blade life up to 10 times longer.

Product ID No.	—Blade Length—		Blade Width Inches	Box/Ctn
	Feet	Meters		
34-404	50	—	3/8	2 / 24
34-402	100	—	3/8	2 / 24

Metric

Product ID No.	—Blade Length—		Blade Width Inches	Box/Ctn
	Feet	Meters		
34-428	50	15	3/8	2 / 24
34-403	100	30	3/8	2 / 24



**CONTRACTOR GRADE™
HEAVY DUTY STEEL LONG TAPES**

Heavy-duty Mylar* “blanket-wrap” coating extends blade life up to ten times longer! Extra strong, 10% thicker blade for longer life. Impact-resistant, safety yellow case. Stainless steel roller cage for smooth blade action. Strong, corrosion resistant, two-position hook.

Product ID No.	Blade Length	Blade Width	Box/Ctn
	Feet	Inches	
34-251	50	3/8	6 / 24
34-252	100	3/8	6 / 24

Metric

Product ID No.	—Blade Length—		Blade Width Inches	Box/Ctn
	Feet	Meters		
34-305	50	15	3/8	6 / 24
34-310	100	30	3/8	6 / 24



HIGH VISIBILITY LONG TAPES

Superior quality and high visibility allows for easy identification. Mylar* protected blade last up to 10 times longer. Rugged, high visibility case is perfect for both professional and DIY'er.

Product ID No.	Blade Length	Blade Width	Color	Box/Ctn
	Feet	Inches		
34-095	50	3/8	Green	6 / 24
34-096	100	3/8	Green	6 / 24



**STEEL LONG TAPES —
3/8" WIDE WHITE BLADE**

Sturdy lightweight molded case designed to fit the hand comfortably and compactly. Easy-to-read blade with 1/8" graduations and foot markings printed in red. True reading hook with double spurs enables one person to take many measurements unassisted. Smooth, easy rewinding action.

Product ID No.	Blade Length	Blade Width	Box/Ctn
	Feet	Inches	
34-450	50	3/8	6 / 24
34-500	100	3/8	6 / 24

Metric

Product ID No.	—Blade Length—		Blade Width Inches	Box/Ctn
	Feet	Meters		
34-389	—	10	3/8	6 / 24
34-383	50	15	3/8	6 / 24
34-390	—	20	3/8	6 / 24
34-393	100	30	3/8	6 / 24
34-391	—	30	3/8	6 / 24

**CONTRACTOR GRADE™
OPEN REEL FIBERGLASS LONG TAPES**

■ Increased number of fiberglass strands means less stretch and better accuracy. Blades are made with PVC, so the tape can be wound wet and easily cleaned. Two-sided printing with multiple formats (fractional/decimal or metric/english). 1/2" wide blade with easy to read markings for more accurate measurements. Rubber grip for comfort. High visibility color makes it easy to find on the job site.



Open Reel — Fractional/Decimal

Product ID No.	Blade Length	Blade Width	Box/Ctn
	feet	inches	
34-790	100	1/2	2 / 6
34-793	200	1/2	2 / 6

Open Reel — Metric/English

Product ID No.	Blade Length		Blade Width	Box/Ctn
	feet	m	inches	
34-791	100	30	1/2	2 / 6
34-794	200	60	1/2	2 / 6

Open Reel — Metric

Product ID No.	Blade Length	Blade Width	Box/Ctn
	Meters	inches	
34-792	30	1/2	2 / 6
34-795	60	1/2	2 / 6

*DuPont Polyester Film.

With its broad offering of levels, squares, bevels and gauges, Stanley® has homeowner and professional Contractor Grade™ layout tools to match any task. Together with measuring tools, these quality hand tools form the basis of successful, quality workmanship. Since 1857, Stanley has been making levels in a variety of lengths and styles for precision determination of level and plumb in carpentry, masonry, and other home projects. The carpenter's square is an indispensable tool for marking 45° and 90° angles and checking corner alignment in large layout and framing work. Unique tools such as the IntelliBeacon leveling and alignment tool and the Compulevel® Elevation Measurement System are also available as part of the Contractor Grade™ line.



Stanley® carpenter's levels are constructed of heavy-duty, I-beam frames and feature highly accurate, replaceable 360° vials for easy reading from all angles.



Stanley® combination squares, the most versatile of layout tools, are ideal for an array of tasks from checking corners, angles, and depth to making measurements and marking layouts.

STANLEY

LAYOUT TOOLS

Stanley® carpenter's square is an indispensable tool for marking 45° and 90° angles and checking corner alignment in large layout and framing work. Stanley® offers these simple, rugged tools in a variety of aluminum or steel models.

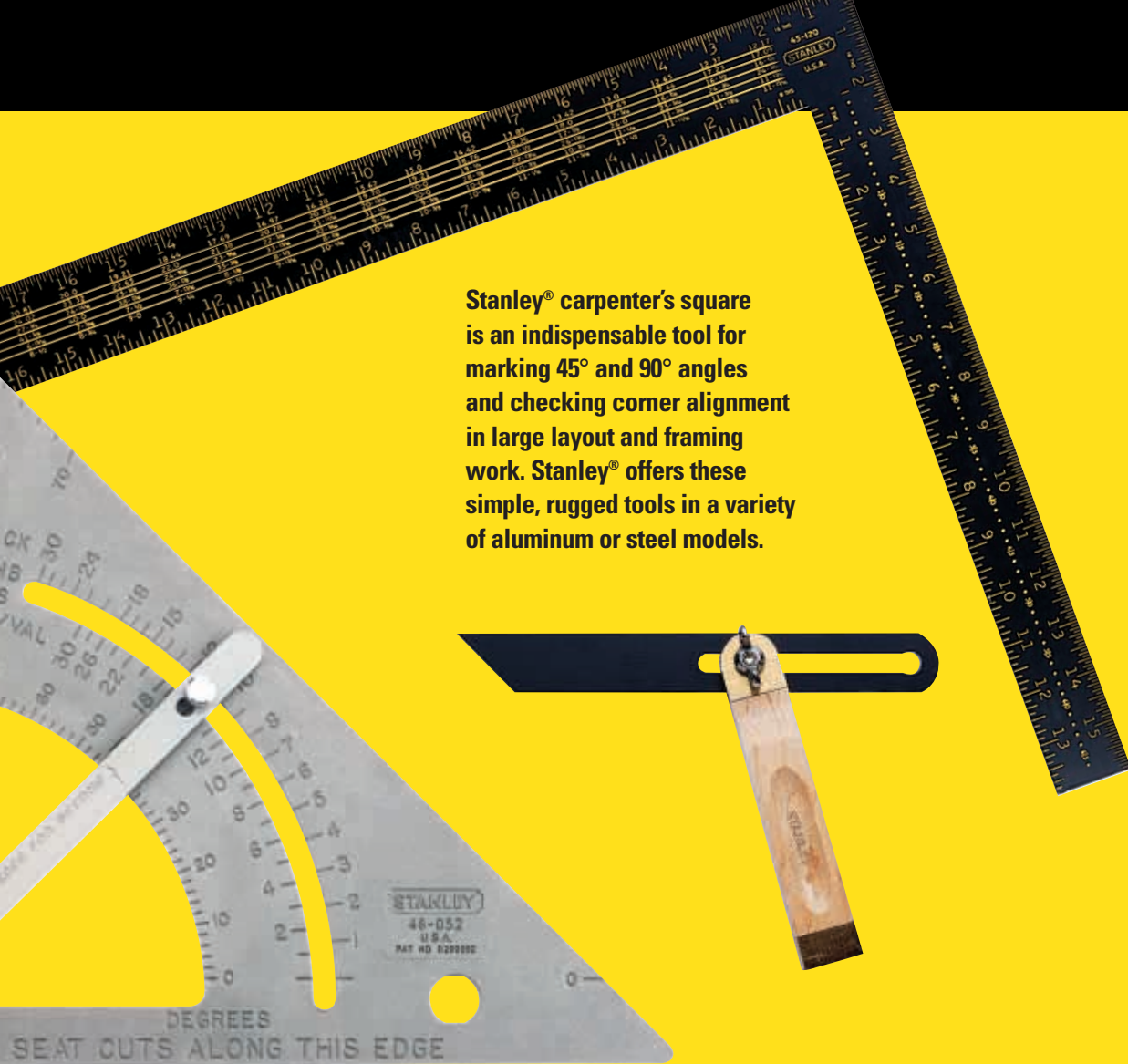

Stanley's IntelliTools™ line of electronic products offers the most technically advanced array of electronic tools available anywhere. From the unique audio/visual sensitivity of our IntelliSensor™ stud sensors, to the pinpoint accuracy of our laser layout tools and Compulevel® Elevation Measurement System, IntelliTools™ electronic products deliver precision at the speed of light.

IntelliTools™

Introducing IntelliTools™ electronic products — a new line of sophisticated tools engineered to help pros work with more precision and greater productivity than ever before.

Stanley's IntelliTools™ line of electronic products offers the most technically advanced array of electronic tools available anywhere. From the unique audio/visual sensitivity of our IntelliSensor™ stud finders, to the pinpoint accuracy of our laser layout tools and Compulevel® Elevation Measurement System, IntelliTools™ electronic products deliver precision at the speed of light.

Look to the tools with no equal. Look to Stanley for the intelligent products your customers deserve.



INTELLISENSOR™ PRO STUD SENSOR

■ Differentiates between wood and metal. Detects and locates studs and joists. Detects live wires for added safety. Detects metal/rebar through 2" of concrete.

LED display and audio horn indicate stud edge and center position for accurate marking. Has built-in automatic pin marker. Manual pencil hole marker. Heavy-duty ABS construction. Belt clip. Automatic calibration.

Product ID No.	Box/Ctn
77-200	2 / 24

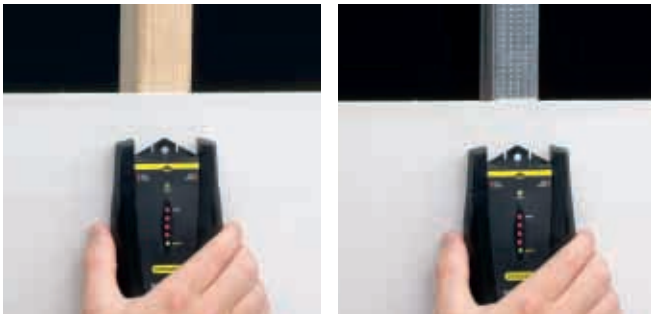

DETECTS AND LOCATES STUDS AND JOISTS. DETECTS LIVE WIRES FOR ADDED SAFETY. DETECTS METAL/REBAR THROUGH 2" OF CONCRETE.

INTELLISENSOR™ STUD SENSOR

■ Detects and locates studs and joists. LED display and audio horn indicates stud edge and center position for accurate marking. Pencil hole marker. Heavy-duty ABS construction. Automatic calibration.



Product ID No.	Box/Ctn
77-100	2 / 8



CONTRACTOR GRADE™ INTELLILEVEL™ LASER RAIL

■ Projects eye-safe, laser dot from end of referencing level visible on almost any surface.

24" in length. Portable I-beam level. Built-in laser to save time and eliminate layout errors. Battery powered. Accurately extends plumb and level reference to a maximum of 100'. Heavy-duty, weather resistant construction. High quality referencing vials can be field calibrated. Comes with a padded shoulder strap carrying case.

Product ID No.	O/A Length in Inches	Box/Ctn
77-001	24	1 / 1



BEAM SPREADER LENS

Changes laser dot into either level or plumb lines for extended layout. Easily snaps in place.

Product ID No.
77-002



Box/Ctn
2 / 4

BEAM SPLITTER LENS

Creates horizontal/vertical axes for measuring 90° angles. Easily snaps in place.

Product ID No.
77-003



Box/Ctn
2 / 4

TRIPOD ADAPTER

Easily fits onto tripod to hold IntelliLevel™ Laser Rail in place. Allows easy leveling adjustment.

Product ID No.
77-004



Box/Ctn
1 / 4



CONTRACTOR GRADE™ INTELLITOOLS™ TRIPOD

■ Heavy-duty aluminum construction. Allows for hands-off use of IntelliLevel™ Laser Rail and other products that require a tripod.

Extendible legs. Easy to use leveling feature. Plumb bob accessory holder. Convenient carry strap.

Product ID No.
77-005

Box/Ctn
0 / 1

INTELLIMEASURE™ LASER ESTIMATOR

■ Safe, visible red laser pointer to precisely locate point to be measured. Greater accuracy in readings 50' range and accurate to +/- .5% of reading. Measuring time: 2-6 seconds. Readings may be taken from top or bottom of the case. Incorporates: areas and volume calculation, memory storage and recall, automatic summing of measurements. Digital display gives readings in both English and metric graduations. Data input beep when buttons pressed. Low battery indicator. Automatic shut off.



SAFE, VISIBLE RED LASER POINTER TO PRECISELY LOCATE POINT TO BE MEASURED.

Product ID No.
77-007

Box/Ctn
2 / 6

INTELLITAPE™ DIGITAL TAPE RULE

Digital or traditional measurement calculation. Memory storage and recall. Freeze display. Zero display at any tape position. Midpoint of measurement function. Auto shut-off and low battery indicator.

Product ID No.	Blade Length Feet	Blade Width Inches	Box/Ctn
77-008	25	1	2 / 6





INTELLIPOINT™ LEVEL

■ Aluminum base for added strength and accuracy. Base fitted with threaded insert for tripod mounting. Accurate to 1/4" over 100 feet. Projects eye-safe light dot visible on almost any surface. Rotating vial that operates through 180°. Made of tough ABS plastic.

Product ID No.	Vials	Box/Ctn
77-010	2	2 / 4



INTELLIPOINT™ — PLUS LEVEL

■ Aluminum base for added strength and accuracy. Base fitted with threaded insert for tripod mounting. Accurate to 1/4" over 100 feet. Projects eye-safe light dot visible on almost any surface. Rotating vial that operates through 180°. Made of tough ABS plastic.

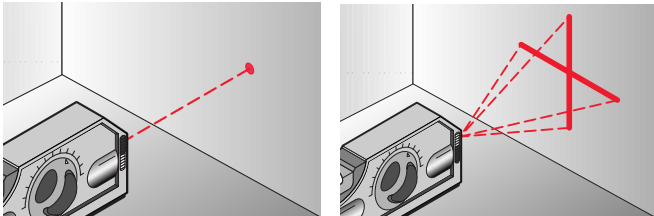

INTERNAL ROTATING VIAL (90° TO 0° TO 90°) WITH DETENTS AND BUILT IN SWITCH TO CHANGE LASER DOT TO CROSS BEAM.

Product ID No.	Vials	Box/Ctn
77-009	2	2 / 4



BLOCK LASER LEVEL

360° rotating laser line and 90° laser. Durable cast aluminum alloy body for long life. Three easy to read eye levels: bulls eye, horizontal, and vertical. Versatile mounting capabilities:

- Bracket allows mounting on traditional levels.
- Magnetic base mounts to steel studs or other metal objects for leveling.
- 1/4" x 20" threaded tripod screw mount.



Product ID No.	O/A Length		Box/Ctn
	Inches	mm	
77-011	3	76	0 / 2



DUAL LASER LEVEL

16" laser level. Fixed position horizontal laser line. Intersecting +/-160° adjustable laser line with 15° detents. Tripod mountable when used with block level base.

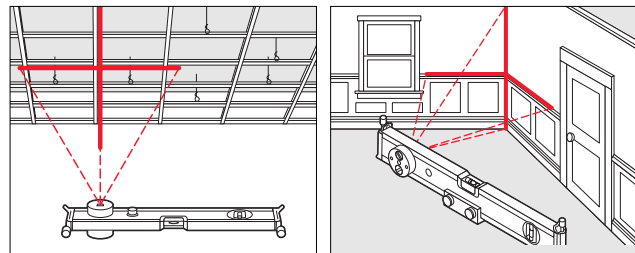

LEVEL CEILING FRAMES.

LEVEL CHAIR RAILS.

Product ID No.	O/A Length		Box/Ctn
	Inches	mm	
77-012	16	406	0 / 2



INTELLIBEACON

360° rotating light beam for leveling and alignment. Electronic self leveling. Fully automatic horizontal and vertical layout. Set horizontal or vertical position without mounts. Chalk line feature. Remote control capabilities.

Product ID No.	O/A Length in Inches	Box/Ctn
77-400	6-3/4 x 6 x 5-1/2	1 / 1



INTELLIEYE DETECTOR

Sensor with bracket for attachment to rod for exterior applications. Working radius of up to 500'. LCD read-out, audio switch, automatic off. For use with rotating laser and other similar lasers.

Product ID No.	O/A Length in Inches	Box/Ctn
77-401	3 x 6 x 1	1 / 4

**“THE BEST MADE LEVEL
IN THE WORLD”**

Our Wood Levels Are Hollow Grind

- ✓ High Quality
- ✓ High Performance



*A Product That Shows Your Pride
In Owning The Best.*

HOLLOW GRIND PROCESS

When placed on a flat surface, light can be seen underneath the center of our level. The slight curvature is an important part of the process of creating a properly functioning wood level.

The curvature is known as “hollow grind,” and is created in the manufacturing process to ensure that when the level is placed on a masonry surface, it will rest on its ends and will not rock back and forth in the middle as it might do if the edge of the level were perfectly flat. This results in a more accurate reading.

Another reason for the hollow grind is in the nature of the wood itself. Over time, wood will gain or lose moisture content, resulting in small dimensional changes. By creating a slight curvature, we are able to compensate for these changes.

Be assured that by including this extra step in our manufacturing, we are producing a superior product.



**CONTRACTOR GRADE™
BRASS BOUND MASON'S LEVEL**

Large, tinted, break-resistant acrylic bent vials are field replaceable, easy to read, extremely accurate (.001 per inch) Rubber gaskets allow for easy, no caulk vial replacement. Individual laser engraved serial numbers for traceability. Solid brass edges are pre-coated to resist tarnish. Hard rubber end caps are screwed into place. Hollow grind process results in more accurate readings, and allows for wood dimensional changes.

Product ID No.	Vials	Length in Inches	Box/Ctn
42-321	6	24	1 / 12
42-347	6	48	1 / 12



**CONTRACTOR GRADE™
WOOD / I-BEAM LEVEL**

Rugged aluminum I-beam frame with select grade wood inserts provides both stability and accuracy. Large tinted, durable acrylic bent vials are field replaceable, easy to read, extremely accurate (within .001 per inch) and break-resistant. Rubber gaskets allow for easy, no-caulk vial cover replacement. Individual laser engraved serial numbers for traceability. Hard rubber end caps are screwed into place.

Product ID No.	Vials	Length in Inches	Box/Ctn
42-422	6	24	1 / 12
42-449	6	48	1 / 12



**CONTRACTOR GRADE™
TOP READ I-BEAM MAGNETIC LEVEL**

Heavy duty aluminum I-beam frame with large protected top read window and shock absorbing end caps. Accurate 360° vials are set directly into I-beam frame and can be read easily from all angles, never needs adjustment. Machined working surfaces. Magnetic strip extends the length of the level. Replaceable vials and covers.

Product ID No.	Vials	Length in Inches	Box/Ctn
42-244	3: 1 Level, 1 Plumb, 1 45°	24	1 / 6
42-486	3: 1 Level, 1 Plumb, 1 45°	48	1 / 3



**CONTRACTOR GRADE™
HEAVY DUTY DOUBLE VIAL I-BEAM LEVEL**

Extra large, rugged aluminum frame with large hand holes and hang hole. Large tinted, break-resistant acrylic vials provide more useful range and are replaceable. Double bent vials for maximum bubble range. Vials mounted directly in frame for unsurpassed accuracy. Machined working surfaces. Accurate to .001 per inch. Pipe groove on one working surface.

Product ID No.	Vials	Length in Inches	Box/Ctn
42-125	6: 2 Level, 4 Plumb	24	0 / 6
42-150	6: 2 Level, 4 Plumb	48	1 / 3
42-173	8: 4 Level, 4 Plumb	72	1 / 1
42-179	8: 4 Level, 4 Plumb	78	1 / 1
42-197	12: 4 Level, 8 Plumb	96	1 / 1



**CONTRACTOR GRADE™
LEVEL CASE**

High density polyethylene for long life. Holes in bottom for drainage. Convenient hang tab for easy storage. Twist lock cap prevents accidental opening.

Product ID No.	Box/Ctn
42-025 Fits most 24" levels	6 / 6
42-027 Fits most 48" levels	6 / 6



TOP READ I-BEAM LEVEL

Heavy duty aluminum I-beam frame with large, protected top read window and shock absorbing end caps. Accurate 360° vials are set directly into I-beam frame can be read easily from all angles, and never needs adjustment. Large screw on vial covers with protective lenses allow maximum visibility. Machined working surfaces. Replaceable vials and covers.

Product ID No.	Vials	Length in Inches	Box/Ctn
42-180	3: 1 Level, 1 Plumb, 1 45°	18	1 / 6
42-240	3: 1 Level, 2 Plumb	24	1 / 6
42-480	3: 1 Level, 2 Plumb	48	1 / 3



BLACK I-BEAM LEVEL

Durable aluminum I-beam frame with hand holes and hang hole. Accurate 360° vials and contrasting black extrusion finish with yellow vial covers provide good visibility. Replaceable vials and covers.

Product ID No.	Vials	Length in Inches	Box/Ctn
42-224	3: 1 Level, 2 Plumb	24	1 / 6
42-248	3: 1 Level, 2 Plumb	48	1 / 3



SILVER I-BEAM LEVEL

Sturdy aluminum I-beam frame with hand holes and hang hole. Easy reading 360° vials. Pipe groove allows use on round objects. Ideal for the occasional DIY'er. Replaceable vials and covers.

Product ID No.	Vials	Length in Inches	Box/Ctn
42-018	2: 1 Plumb, 1 Level	18	6 / 6
42-824	3: 1 Plumb, 1 Level, 1 45°	24	6 / 6
42-436	3: 1 Plumb, 1 Level, 1 45°	36	6 / 6
42-748	3: 1 Plumb, 1 Level, 1 45°	48	3 / 3

**CONTRACTOR GRADE™
LIGHTED TORPEDO LEVEL**

Tinted vials illuminate with the push of a button. Ideal when working in dark areas (basements, under cabinets, etc). Magnetic strip allows hands-free operation on metal surfaces. Durable, aluminum I-beam frame with large, top read vial window. Grooved surface for pipe and conduit work. 2 AAA DURACELL® batteries included.

42-512



42-512

**CONTRACTOR GRADE™
CAST ALUMINUM
TORPEDO LEVEL**

Durable, heavy-duty cast aluminum frame with large, top read vial window. Tinted 360° vials for easy reading are replaceable in seconds. Ideal for pipe and conduit work. Magnetic strip allows hands-free operation on metal surfaces.

42-465



42-465

**I-BEAM TORPEDO
LEVEL**

Heavy-duty aluminum I-beam extrusion for durability. Three easy-to-read 360° vials for plumb, level and 45° applications. Large top read window allows viewing vial from any angle. Grooved top surface for use on round objects. Magnetic strip for hands free use on metal surfaces.

42-308/42-311



42-311

Product ID No.	Vials	Length in Inches	Box/Ctn
42-512 <i>Magnetic</i>	3	9	6 / 36

Product ID No.	Vials	Length in Inches	Box/Ctn
42-465 <i>Magnetic</i>	3	9	6 / 36

Product ID No.	Vials	Length in Inches	Box/Ctn
42-309	3	9	6 / 36
42-311 <i>Magnetic</i>	3	9	6 / 36

9" TORPEDO LEVEL

Top reading. Made of tough, shock resistant ABS plastic material. Three replaceable 360° vials: plumb, top read, and 45°. Base on 42-264 has strong magnetic strip that holds to iron and steel surfaces for hands-free operation.

42-191/42-264



42-191

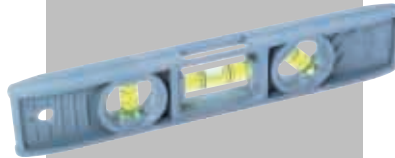

42-291

8" TORPEDO LEVEL

Top reading feature allows greater visibility. Made of tough ABS plastic. Level, plumb and 45° vial. Base of 42-291 has magnetic strip that holds to iron and steel surfaces for hands-free operation.

42-294/42-291

Product ID No.	Vials	Length		Box/Ctn
		Inches	mm	
42-191	3	9	229	6 / 36
42-264 <i>Magnetic</i>	3	9	229	6 / 36

Product ID No.	Vials	Length		Box/Ctn
		Inches	mm	
42-294	3	8	203	6 / 36
42-291 <i>Magnetic</i>	3	8	203	6 / 36

ALUMINUM LINE LEVEL

Lightweight, aluminum construction. Special hooks hold to line which allows level to slide freely for easy positioning. Bottom is flat for surface leveling. 360° yellow vial.

Product ID No.	Vials	Length		Box/Ctn
		Inches	mm	
42-287	1	3-3/32	79	6 / 72

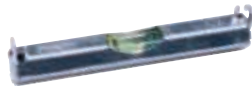

HIGH VISIBILITY PLASTIC LINE LEVEL

High visibility plastic line level is accurate with a 360° vial. Level is lightweight yet very durable. Flat base is ideal for surface leveling.

Product ID No.	Color	Vials	Length		Box/Ctn
			Inches	mm	
42-184	Orange	1	3	76	6 / 72
42-190	Green	1	3	76	6 / 72



POCKET LEVEL

Lightweight body with pocket clip made of tough, plastic materials with a strong acrylic 360° vial. Base is grooved for use on pipes, etc.

Product ID No.	Vials	Length		Box/Ctn
		Inches	mm	
42-189	1	5	127	6 / 0



UTILITY LEVEL

Has two 360° vials. A versatile level designed for leveling campers, trailers, cameras, instruments, storage units, refrigerators, etc. Level in two directions at one time. Apply to surface with screws.



Product ID No.	Vials	Length		Box/Ctn
		Inches	mm	
42-182	2	2-1/16	52	6 / 72

STRAIGHT EDGE

Strong, lightweight aluminum construction.

Product ID No.	Length		Box/Ctn
	Inches	mm	
35-338	36	914	10 / 10

CONTRACTOR GRADE™ STEEL RAFTER SQUARE

Cold rolled steel designed to maintain accuracy of square. Individually inspected for accuracy. Deep graduations are filled with yellow paint for superior readability in all light conditions. Surface protected to resist corrosion.

Product ID No.	Finish	Length		Graduation		Box/Ctn
		Body	Tongue	Face	Back	
45-119 <i>English</i>	Blued	24"	16"	1/16", 1/8"	1/16", 1/10", 1/12"	3 / 3

CONTRACTOR GRADE™ ALUMINUM RAFTER SQUARE

Extra thick aircraft grade aluminum for durability and maintaining accurate square. Individually inspected for accuracy. Deep graduations are filled with yellow paint for superior readability in all light conditions. Surface protected to resist corrosion.

Product ID No.	Finish	Length		Graduation		Box/Ctn
		Body	Tongue	Face	Back	
45-011 <i>English</i>	Black	24" x 2"	16" x 1-1/2"	1/16", 1/8"	1/16", 1/10", 1/12"	3 / 3

RAFTER SQUARE BOOK

Detailed instruction manual is in two sections. The first section explains in detail the description of the square; roof framing and types; common, hip, valley and jack rafters; brace and Essex board measures; laying out a stair; plus more. The second section is rafter tables arranged by roof pitch for easy "one-page" reference. Book is bound to allow pages to flip freely and lie flat. Fits into shirt or back pocket.

Product ID No.	Box/Ctn
45-720	10 / 50



STEEL RAFTER / ROOFING SQUARE

Embossed graduations and figures on work-hardened steel for durability and long life. 45-910 has Essex board measure, octagon scale, brace scale, and rafter table. 45-530 has metric roofing table. Buffed finish with a clear lacquer that resists rust.

Product ID No.	Finish	Length		Graduation		Box/Ctn
		Body	Tongue	Face	Back	
45-910 <i>English</i>	Buffed	24" x 2"	16" x 1-1/2"	1/16", 1/8"	1/16", 1/10", 1/12"	6 / 6
45-530 <i>Metric</i>	Buffed	600 x 50mm	400 x 38mm	2mm	2mm	6 / 6

STEEL CARPENTER'S SQUARES

Tempered steel designed for durability. Deep graduations for easy reading on face and back. Surface protected with a clear finish that resists rust. Reverse reading scale.

Product ID No.	Finish	Length		Graduation		Box/Ctn
		Body	Tongue	Face	Back	
45-500 <i>English</i>	Buffed	24" x 2"	16 x 1-1/2"	1/8"	1/8"	6 / 6
45-600 <i>Metric/Eng.</i>	Buffed	24" x 2"	16 x 1-1/2"	1/8"	1/8"	6 / 6

ALUMINUM CARPENTER'S SQUARE

High tempered aluminum for maximum durability. Useful tables and information stamped into square, such as: new lumber scale, decimal equivalent table, metric conversion table, formula for squaring a foundation 45°, 60°, 30° angle markings, volume and area formulas, wood screw gauge table, nail sizes (common and finish) quantity per pound, depth scale. Deep, long-wearing graduations for easy reading. Protective lacquered coating resists corrosion.

Product ID No.	Finish	Length		Graduation		Box/Ctn
		Body	Tongue	Face	Back	
45-300 <i>English</i>	Buffed	24" x 2"	16" x 1-1/2"	1/8"	1/8"	6 / 6

12" STEEL SQUARE

Work hardened steel designed for durability. Deep long wearing graduations for easy reading. Surface protected with a clear finish that resists rust.

Product ID No.	Finish	Length		Graduation		Box/Ctn
		Body	Tongue	Face	Back	
45-912 <i>English</i>	Buffed	12" x 1-1/2"	8" x 1"	1/16"	1/16"	6 / 6

12" ALUMINUM SQUARE

Permanently embossed graduations and figures are filled with yellow color against a black finish for superior readability. High tempered aluminum for maximum durability.

Product ID No.	Finish	Length		Graduation		Box/Ctn
		Body	Tongue	Face	Back	
45-012 <i>English</i>	Black	12" x 1-1/2"	8" x 1"	1/16"	1/16"	6 / 6

8" MINI-SQUARE™ STEEL SQUARE

Has many features of the large Stanley® Steel Squares including accurately stamped easy-to-read graduations on both sides. Edges are accurate and true. 1/16" graduations on face and back. Lacquered finish.

Product ID No.	Finish	Length		Graduation		Box/Ctn
		Body	Tongue	Face	Back	
45-068 <i>English</i>	Buffed	8" x 1-1/2"	6" x 1"	1/16"	1/16"	12 / 12

SAW GLIDE® LAYOUT TOOL

A new layout tool designed for making circular saw cuts on any lumber, but most specifically, on composite I-beam trusses. The Saw Glide is an improvement over other types of "speed square" layout tools/saw guides because it will cover the full width of a composite I-beam truss and provide for a shelf for the base of a circular saw to ride on over the dip in the center span of the I-beam. It also provides graduated markings along its edge to allow for accurate angle cuts.

Product ID No.	O/A Length in Inches	Box/Ctn
46-068	16 x 12 x 1	0 / 6

CONTRACTOR GRADE™ STAIR GAUGES

Designed to fit onto a square for stair layout. Solid brass body. Fits most carpenter squares. Set of two.



Product ID No.	Box/Ctn
45-711 <i>Brass</i>	3 / 36

STANLEY®

Inventors of
The Carpenter's
Square in 1817

CONTRACTOR GRADE™
12" SLOTTED BLADE
COMBINATION SQUARE

Reversible slotted blade. Heavy-duty die cast metal handle. Solid brass knobs are textured for easy adjustments. Vial individually regulated to ensure accuracy. Unique, high visibility black blade with deep etchings filled with yellow paint. Coated blade resists rust.



Product ID No.	O/A Length		Box/Ctn
	Inches	mm	
46-022	12	305	0 / 3

CONTRACTOR GRADE™
16" COMBINATION SQUARE

16" blade allows scribing on 10" and 12" stock. Heavy-duty die cast metal handle with precision-ground edges. Solid brass knobs are textured for easy adjustments. Vial individually regulated to ensure accuracy. Blade graduations are filled with yellow paint for superior readability. Coated blade resists rust.



Product ID No.	O/A Length		Box/Ctn
	Inches	mm	
46-131	16	407	0 / 3

CONTRACTOR GRADE™
COMBINATION SQUARE

Heavy-duty die cast metal handle. Solid brass knobs are textured for easy adjustments. Vial individually regulated to ensure accuracy. Unique, high visibility black blade with deep etchings filled with yellow paint. Coated blade resists rust.



Product ID No.	O/A Length		Box/Ctn
	Inches	mm	
46-123	12	305	0 / 3
46-323	7	178	6 / 6

COMBINATION SQUARE

Heavy duty die cast metal handle has built in accuracy and durability. Coated blade resists rust. Scriber conveniently stores in handle. Level vial increases versatility. Available in English/Metric.



Product ID No.	O/A Length		Box/Ctn
	Inches	mm	
46-024 English/Metric	12	305	0 / 3

COMBINATION SQUARE

Die cast metal handle has built in accuracy and durability. Coated blade resists rust. Scriber conveniently stores in handle. Level vial increases versatility. Available in English, Metric, and English/Metric.



Product ID No.	O/A Length		Box/Ctn
	Inches	mm	
46-222 English	12	305	0 / 6
46-029 Metric	11-13/16	300	0 / 6
46-028 English/Metric	12	305	0 / 6

6" MINI COMBINATION SQUARE

Compact size fits easily into pouch or pocket. Precision die cast body has built in accuracy and durability. 6" coated blade resists rust. Deep debossed graduations in 16ths and 32nds of an inch are more accurate and longer lasting. Scriber conveniently stores in handle. Level vial increases versatility.



Product ID No.	O/A Length		Box/Ctn
	Inches	mm	
46-324	6	150	6 / 6

PLASTIC HANDLE COMBINATION SQUARE

Durable plastic handle for long life. Coated blade resists rust. Deep debossed graduations are more accurate and longer lasting. Level vial increases versatility. Available in English and Metric.



Product ID No.	O/A Length		Box/Ctn
	Inches	mm	
46-012 English	12	305	0 / 6
46-017 Metric	11-13/16	300	0 / 6

6" PLASTIC HANDLE MINI COMBINATION SQUARE

Compact size fits easily in pouch or pocket. Durable plastic handle for long life. 6" coated blade resists rust. Deep debossed graduations in 16ths and 32nds of an inch are more accurate and longer lasting. Level vial increases versatility.



Product ID No.	O/A Length		Box/Ctn
	Inches	mm	
46-322	6	150	0 / 6

**CONTRACTOR GRADE™
ADJUSTABLE QUICK SQUARE®
LAYOUT TOOL**

Rafter layout square with adjustable arm — a Stanley exclusive. Ideal for marking repetitive cuts accurately. Black body with yellow graduations for maximum readability in all light conditions. Heavy duty aluminum construction is lightweight yet durable. Common/Jack and Hip/Valley scales. Can be used as a saw guide, bevel, or protractor.

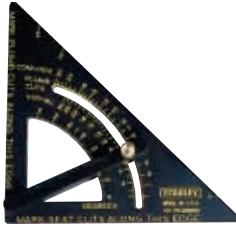

Product ID No.	Base Length	Rule Length	Box/Ctn
46-053	10-3/4"	6-3/4"	6 / 6

**CONTRACTOR GRADE™
QUICK SQUARE® LAYOUT TOOL**

Rafter layout square with black body and yellow graduations for maximum readability in all light conditions. Aluminum construction is lightweight yet durable. Extra thick body for use as a saw guide with a 0° to 90° protractor scale.

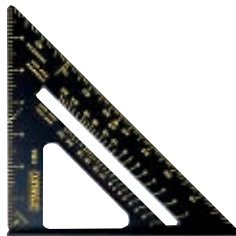

Product ID No.	Base Length	Rule Length	Box/Ctn
46-071	10-1/4"	6-3/4"	6 / 6

**ADJUSTABLE QUICK SQUARE®
LAYOUT TOOL**

Exclusive movable locking arm insures fast, accurate and repeatable measurements. Use as a power saw guide, protractor, rafter square or combination square. Buffed finish.



Product ID No.	Finish	Base Length	Rule Length	Box/Ctn
46-050	Buffed	10-3/4"	6"	6 / 6
46-052	Buffed	16-1/4"	10"	4 / 4

**QUICK SQUARE®
LAYOUT TOOL**

This layout tool is made of rugged, die-cast aluminum for durability. Deep, permanent graduations are designed for easy reading and long life. Can be used as a rafter square, protractor or circular saw guide.

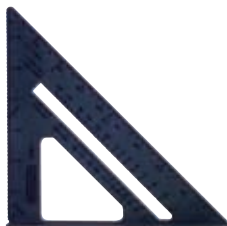

Product ID No.	Base Length	Rule Length	Box/Ctn
46-064	10-1/4"	6-3/4"	6 / 6
46-065 <i>Includes Instruction Booklet</i>	10-1/4"	6-3/4"	6 / 6

**QUICK SQUARE®
POCKET SQUARE**

Versatile layout tool works as a rafter square, try square, protractor, or power saw guide. Heavy duty ABS plastic body. Detailed instruction book included.



Product ID No.	Base Length	Rule Length	Box/Ctn
46-060	10-13/16"	6-3/4"	6 / 6

**CONTRACTOR GRADE™
HARDWOOD TRY SQUARE**

Select, hard rock maple handle with solid brass face plate. 1/8" graduations. Coated blade resists rust. Handle lacquer coated.

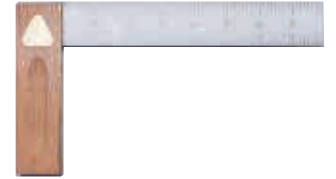

Product ID No.	Blade		Blade Width Inches	Handle		Box/Ctn
	Inches	mm		Inches	mm	
46-209	8	203	1-1/2	5-3/8	136	6 / 6

**CAST ZINC HANDLE
TRY / MITRE SQUARE**

Precision machined for accuracy. 1/8" graduations and numbers are stamped for durability and long life. Handle finished in black and protected with oil finish. Blade coated with acrylic wax to resist rust. 1-1/2" wide blade for stud marking.



Product ID No.	Blade		Handle		Box/Ctn
	Inches	mm	Inches	mm	
46-522 <i>English</i>	8	203	4-7/8	124	6 / 6

**PLASTIC HANDLE
TRY / MITRE SQUARE**

Lightweight square for laying out 45° and 90° angles. 8" blade with 1/8" graduations.



Product ID No.	Blade		Blade Width Inches	Handle		Box/Ctn
	Inches	mm		Inches	mm	
46-502 <i>English</i>	8	203	1-1/2	5-1/8	130	6 / 60

MAGNETIC STUD FINDER

A useful tool for locating wall studs. Magnet is attracted to steel nails used to hold drywall to studding. Base of the stud finder is notched for marking once studs are located.



Product ID No.	—O/A Length—		Box/Ctn
	Inches	mm	
47-400	1-3/8 x 1-3/8 x 1-1/4	35 x 35 x 32	6 / 36

CONTRACTOR GRADE™ METAL T-BEVEL

Heavy-duty metal die cast handle. Unique locking screw at bottom of handle. Coated blade resists rust.



Product ID No.	—Blade—		—Handle—		Box/Ctn
	Inches	mm	Inches	mm	
46-801	8	203	5	127	6 / 0

CONTRACTOR GRADE™ HARDWOOD T-BEVEL

Durable steel blade coated to resist rust. Select, hard rock maple wood handle. Recessed grip area. Solid brass end plates.



Product ID No.	—Blade—		—Handle—		Box/Ctn
	Inches	mm	Inches	mm	
46-813	8	203	5-1/2	140	6 / 0

T-BEVEL

Tough plastic handle with handy grip. Steel blade and blade locking device.



Product ID No.	—Blade—		—Handle—		Box/Ctn
	Inches	mm	Inches	mm	
46-825	8	203	5-1/2	140	6 / 36

FINE WOODWORKING ROSEWOOD T-BEVEL

The "T" Bevel or Sliding Bevel can be adjusted to form any angle. This is particularly helpful when transferring angles for multiple cuts or setting angles with the help of a protractor. The very best materials are used to make this bevel including high quality rosewood for the body with brass tips and blued steel blade.

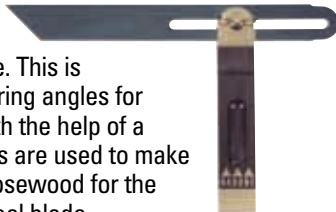

Product ID No.	—Blade—		—Handle—		Box/Ctn
	Inches	mm	Inches	mm	
46-702	9	229	5-1/2	140	1 / 50

HARDWOOD MARKING GAUGE

Fixed tempered steel pin, held at proper angle, scores a perfect line. Bar and head made of hardwood. Graduated in 16ths of an inch for six inches.



Product ID No.	—O/A Length—		Box/Ctn
	Inches	mm	
47-061	8-7/8	214	5 / 0

STYRENE MARKING GAUGE

Made of tough impact styrene with metal face plate for long wear. Thumbscrew and shoe. One side graduated in 16ths of an inch and reverse side in 2mm graduations.



Product ID No.	—O/A Length—		Box/Ctn
	Inches	mm	
47-064	8-7/16	214	5 / 30

SINGLE BAR STEEL MARKING GAUGE

Used for scoring a knife-like line on metal or wood. Single face head carefully machined. Adjustable single bar with tempered steel point. Bar is graduated in 16ths of an inch for five inches. Nickel plated finish on bar.



Product ID No.	—O/A Length—		Box/Ctn
	Inches	mm	
47-090	6-9/16	167	1 / 0

DOUBLE BAR STEEL MARKING GAUGE

Single face head carefully machined. Adjustable double bars with steel points score perfect lines. Bars are 6-9/16" long and graduated in 16ths of an inch for five inches. Nickel plated finish on bar. For use on metal or wood.



Product ID No.	—O/A Length—		Box/Ctn
	Inches	mm	
47-091	6-9/16	167	1 / 0

FINE WOODWORKING ROSEWOOD MARKING AND MORTISE GAUGE

Top quality Marking Gauge can serve as a Mortise Gauge. One side of the beam has a single pin for marking and the other side has two pins, one fixed and the other slides to adjust the width of your mortise. The select rosewood body is detailed with solid brass facing plates, mortise adjustment and thumb screw.



Product ID No.	—O/A Length—		Box/Ctn
	Inches	mm	
46-703	8-1/4" beam length		1 / 20

WING DIVIDER (COMPASS)

Special adjusting screw and tension spring for precision adjusting. Black finish with hardened steel points.



Product ID No.	—O/A Length—		Box/Ctn
	Inches	mm	
47-017	7	178	1 / 0

**CONTRACTOR GRADE™
GEAR DRIVE CHALK LINE REEL**

Super fast 4:1 rewind ratio saves time. Tough ABS safety yellow case. Universal hook designed to take on-the-job punishment. Sliding door to fill chalk reel easily.

47-120



**CONTRACTOR GRADE™
CHALK LINE REEL**

Durable, heavy-duty die cast body for extra long life. Long wearing felt gasket hugs line and distributes uniform chalk coating. Universal hook has been designed to endure the rigors of everyday use. Can be used as plumb bob.

47-051/47-099

CHALK LINE REEL

Shatter resistant polypropylene case. Easy to fill. Free wheeling crank mechanism.

47-150, 47-200

**REPLACEMENT
CHALK LINE**

High quality replacement line, 100 ft. (30m) on reel.

47-101

Product ID No.	Length		Box/Ctn
	Feet	Meters	
47-120	100	30	0 / 6

Product ID No.	Length		Box/Ctn
	Feet	Meters	
47-051	50	15	2 / 24
47-099	100	30	2 / 24

Product ID No.	Length		Box/Ctn
	Feet	Meters	
47-150	50	15	6 / 24
47-200	100	30	6 / 24

Product ID No.	Length		Box/Ctn
	Feet	Meters	
47-101	100	30	6 / 36

**CONTRACTOR GRADE™
PLUMB BOB**

Black oxide replaceable steel tip. Cap permits attachment of cord. Rust proof, powder-coated yellow cast body is easy to locate and use.



Product ID No.	Length		Size		Box/Ctn
	Inches	mm	oz.	gr.	
47-970	4-3/4	121	5	170	6 / 6
47-971	5-1/4	133	8	227	6 / 6
47-972	6-1/8	158	12	340	6 / 6

**CONTRACTOR GRADE™
5 LB. CHALK**

High grade chalk in a choice of two vivid colors. Packed in plastic canisters with easy-pouring spout. 5 lb. container.



8 OZ. CHALK

8 oz. plastic bottle with twist-to-open cap.

4 OZ. CHALK

4 ounce plastic bottle with twist-to-open cap.

Product ID No.	Size in Pounds	Color	Box/Ctn
47-502	5	Blue	4 / 4
47-505	5	Red	4 / 4

Product ID No.	Size in Ounces	Color	Box/Ctn
47-803	8	Blue	12 / 12
47-804	8	Red	12 / 12

Product ID No.	Size in Ounces	Color	Box/Ctn
47-403	4	Blue	12 / 12
47-404	4	Red	12 / 12



47-679



47-672



47-671

**CONTRACTOR GRADE™
3 PIECE GEAR DRIVE LAYOUT SET**

150 ft gear drive chalk line reel with a 4 oz. bottle of blue chalk and aluminum line level.

Product ID No.	Box/Ctn
47-679	0 / 5

3 PIECE LAYOUT SET

50 ft. chalk line reel with a 4 oz bottle of blue chalk and plastic line level.

Product ID No.	Box/Ctn
47-672	5 / 5

CHALK AND REEL SET

50 ft. shatter resistant polypropylene chalk line reel and 4 oz. bottle of blue chalk.

Product ID No.	Box/Ctn
47-671	5 / 5

Once careful layout and cutting is accomplished, the next step in a project is assembly, a phase in which Stanley® striking and struck tools are well suited. Stanley makes a comprehensive assortment of hammers designed to meet the needs of any striking job. A range of quality prying tools are also a must for pulling apart assembled materials. Stanley's consumer and Contractor Grade™ fiberglass, steel and hardwood hammers are available in a range of weights, types and styles. Stanley wood chisels, a preferred choice among woodworking enthusiasts, feature large, comfortable grips with high carbon, heat-treated blades and precision-ground cutting edges.



Heavy-duty Stanley® prying and pulling jobs include an array of nail pullers, ripping bars, and pry bars, and other tools. The high-carbon steel construction of a ripping bar makes it superb for pulling large spikes or for heavy demolition work.



STANLEY

STRIKING TOOLS

For straightening deck and joist boards faster and easier, a BoardBender, designed by and for builders, has been added to the Contractor Grade™ hand tools product line.



Cushion grip nail sets for a non-slip grip. Ribbed grip for precision hold. Made from hardened, precision milled steel for extra long life. Designed by and for the pro.



Cushioned grip for comfort. Diameter shape for lower grip force control to reduce vibrational shock energy generated from hammering.



The over-molded, chemically resistant jacket provides overstrike protection.



Comfort Grip
Reduced Slip
Reduced Vibration

**CONTRACTOR GRADE™
ANTIVIBE™ HAMMERS**

■ Designed to reduce exposure to vibrational energy generated during repetitive hammering impacts to the work-piece.

The high carbon, polished steel head is precision balanced for a superior swing. Patented head-to-handle assembly for added safety. The handle is constructed from anti-vibration shank materials and components and is designed to minimize exposure to shock waves from hammering. This hammer provides eight times better vibration reduction compared to the leading all-steel hammer. The grip is cushioned for comfort and is an ideal diameter and shape to allow lower grip force to control the hammer. This reduces coupling and vibrational shock energy generated from hammering. The over-molded, chemically resistant, jacket provides overstrike protection.

Nail Hammers

Product ID No.	—Overall Length—		—Weight—		Box/Ctn
	in	mm	oz.	grams	
51-741 Curve Claw	13-1/4	335	16	450	4 / 24
51-742 Rip Claw	13-1/4	335	16	450	4 / 24
51-743 Curve Claw	13-1/4	335	20	570	4 / 24
51-744 Rip Claw	13-1/4	335	20	570	4 / 24

Framing Hammers

Product ID No.	—Overall Length—		—Weight—		Box/Ctn
	in	mm	oz.	grams	
51-748 Plain Face	15	381	24	680	2 / 12
51-749 Checkered Face	15	381	24	680	2 / 12
51-750 Checkered Face	15	381	28	795	2 / 12
51-753 Checkered Face	15	381	33	937	2 / 12



Comfort Grip
Reduced Slip
Reduced Vibration

Jacketed Graphite Handle Construction
Extruded for maximum bend strength. Shock absorption.



Solid graphite core rod extends to nib of handle.

Molded jacket for complete overstrike protection, maximum shock and vibration absorption. Chemically resistant.

**CONTRACTOR GRADE™
JACKETED GRAPHITE HAMMERS**

Jacketed graphite handle to reduce shock and vibration. Has the “feel” of wood but with overstrike protection. This handle just dents when missed. High carbon, polished steel head has been precision balanced for a superior swing. New ribbed grip handle allows air to cool hand and channel sweat away. Patented head-to-handle assembly. Smooth handle-to-grip contour — won’t hang up on your tool belt. Nib at end of handle prevents hammer from slipping off hand.

Nail Hammers

Product ID No.	—Overall Length—		—Weight—		Box/Ctn
	in	mm	oz.	grams	
51-440 Curved Claw	13	330	13	370	4 / 12
51-441 Curved Claw	13-1/4	337	16	450	4 / 24
51-442 Rip Claw	13-1/4	337	16	450	4 / 24
51-443 Curve Claw	13-1/4	337	20	570	4 / 24
51-444 Rip Claw	13-1/4	337	20	570	4 / 24

Framing Hammers

Product ID No.	—Overall Length—		—Weight—		Box/Ctn
	in	mm	oz.	grams	
51-446 Plain Face	15	381	20	570	2 / 12
51-447 Checkered Face	15	381	20	570	2 / 12
51-448 Plain Face	15	381	24	680	2 / 12
51-449 Checkered Face	15	381	24	680	2 / 12
51-450 Checkered Face	15	381	28	795	2 / 12

HAMMER SAFETY RULES

- Always wear safety goggles when hammering.
- Always strike squarely to avoid glancing blows.
- Always discard hammer when face shows excessive wear, mushrooming, chipping, dents, etc.
- Never strike with side of hammer.
- Never strike one hammer with another.
- Never use a hammer with a loose or damaged handle.





16 OZ. JACKETED FIBERGLASS NAIL HAMMERS

Jacketed design provides superior overstrike protection for long life and safety. Cushion grip handle for added comfort. Rim-Tempered™ face reduces chipping. Fiberglass handle allows for maximum shock absorption. Bright yellow color makes it easy to locate.

Product ID No.	—Overall Length—		—Weight—		Box/Ctn
	in	mm	oz.	grams	
51-110 Curved Claw	13-1/4	335	16	450	6 / 6
51-518 Rip Claw	13-1/4	335	16	450	0 / 6



WOOD HANDLE FRAMING HAMMERS

Select straight grain, hickory handle. Triple wedge head-to-handle assembly prevents any loosening. Octagon contour handle for a controlled swing. High carbon, high polish steel head.

Product ID No.	—Overall Length—		—Weight—		Box/Ctn
	in	mm	oz.	grams	
51-356 Plain Face	16	406	20	570	2 / 12
51-357 Checkered Face	16	406	20	570	2 / 12
51-359 Plain Face	16	406	24	680	2 / 12
51-360 Checkered Face	16	406	24	680	2 / 12
51-362 Checkered Face	18	457	28	795	2 / 12



FIBERGLASS NAIL HAMMERS

High strength fiberglass handle core for durability. One-piece gray molded outer jacket to prevent fiberglass splintering. Contoured textured, ribbed vinyl grip minimizes slipping. Semi-polished high carbon 16 oz. head. Curve and rip claw available. Head fully heat treated with Rim Tempered™ face to reduce chipping.

Product ID No.	—Overall Length—		—Weight—		Box/Ctn
	in	mm	oz.	grams	
51-098 Curved Claw	13	330	16	450	6 / 6
51-099 Rip Claw	13	330	16	450	0 / 6



WOOD HANDLE NAIL HAMMERS

High-carbon, steel head. Fully heat treated and polished bell face. Hickory handle.

Product ID No.	—Overall Length—		—Weight—		Box/Ctn
	in	mm	oz.	grams	
51-613 Curved Claw	11-1/2	290	7	200	0 / 6
51-713 Curve Claw	13	330	13	370	0 / 6
51-616 Curved Claw	13-1/4	335	16	450	0 / 6
51-716 Rip Claw	13-1/4	335	16	450	6 / 6



WOOD HANDLE NAIL HAMMERS

Select straight grain, hickory handle. Triple wedge head-to-handle assembly prevents any loosening. Octagon contour handle for a controlled swing. High carbon, high polish steel head.

Product ID No.	—Overall Length—		—Weight—		Box/Ctn
	in	mm	oz.	grams	
51-350 Curved Claw	13	330	13	370	4 / 24
51-351 Curved Claw	13-1/4	337	16	450	4 / 24
51-352 Rip Claw	13-1/4	337	16	450	4 / 24
51-353 Curved Claw	13-1/4	337	20	570	4 / 24
51-354 Rip Claw	13-1/4	337	20	570	4 / 24
51-355 Long Handle Rip Claw	16	406	20	570	2 / 12

**FOR SAFETY AND PERFORMANCE
SELECT THE PROPER HAMMER**

NAIL HAMMERS: For common and finishing nail sets. Not for masonry nails, cold chisels and other metal.



**WARNING: WEAR SAFETY GOGGLES
USER AND BYSTANDER.**



Comfort Grip
Reduced Slip
Reduced Vibration

CONTRACTOR GRADE™

JACKETED GRAPHITE BALL PEIN HAMMERS

Heat-treated, high-carbon steel head for superior strength and durability. Rim Tempered™ process around the striking face minimizes chipping from off-center strikes — a Stanley safety exclusive. Patented head-to-handle assembly for a permanent fit. Molded jacket over graphite handle means maximum overstrike protection. Cushioned grip, molded jacket is designed to absorb shock. Ergonomically designed grip is contoured for working comfort while the ribbed channels allows air to ventilate and cool hand, allows moisture to escape. Flared end provides greater control and reduces slippage. Exceeds ANSI safety specifications.

Product ID No.	—Overall Length—		—Weight—		Box/Ctn
	in	mm	oz.	grams	
54-708	12-1/4	311	8	230	4 / 24
54-712	13	345	12	340	4 / 24
54-716	14	355	16	450	4 / 24
54-724	15	381	24	680	4 / 24
54-732	16	405	32	910	4 / 24



BALL PEIN HAMMERS

High-carbon, steel forged head, hardened and tempered. Rim Tempered™ face minimizes chipping, assures greater safety. Select clear lacquered hickory handle. Polished face and pein.

*54-004 does not have Rim-Tempered™ face.

Product ID No.	Size	—Overall Length—		—Weight—		Box/Ctn
		in	mm	oz.	grams	
54-004*	5/0	10-7/8	275	4	110	6 / 24
54-008	3/0	12-1/4	311	8	230	6 / 24
54-012	2/0	13	345	12	340	6 / 24
54-016	0	14	355	16	450	6 / 24
54-024	2	15	381	24	680	6 / 24
54-032	4	16	405	32	910	4 / 12
54-040	6	16	405	40	1130	4 / 12
54-048	8	16	405	48	1360	4 / 12



BRICKLAYER'S WOOD HANDLE HAMMERS

Forged, heat-treated steel head. Clear lacquered hickory handle.

Product ID No.	—Overall Length—		—Weight—		Box/Ctn
	in	mm	oz.	grams	
54-431	11	280	18	510	4 / 24
54-435	11	280	24	680	4 / 24

FOR SAFETY AND PERFORMANCE SELECT THE PROPER HAMMER

BALL PEIN HAMMERS:

For cold chisels, punches, rivets and shaping metal.

BRICK HAMMERS:

For setting splitting bricks, tiles, concrete blocks. Also for chipping mortar.

BLACKSMITH HAMMERS:

For spikes, stakes, cold chisels, hardened nails, etc.



CONTRACTOR GRADE™

JACKETED FIBERGLASS ENGINEER HAMMERS

Forged steel head — hardened and tempered. Faces machine finished. Yellow colored, jacketed fiberglass handle provides greater visibility, strength and durability.

Product ID No.	—Weight—		—Head Length—		Box/Ctn
	lbs.	kilograms	inches	mm	
56-202	2.5	1.1	4-3/8	112	4 / 4
56-204	4	1.8	5-1/4	135	4 / 4

CONTRACTOR GRADE™

HICKORY HANDLE ENGINEER HAMMERS

Forged steel head — hardened and tempered. Faces machine finished. Selected clear lacquered hickory handle.

Product ID No.	—Weight—		—Head Length—		Box/Ctn
	lb.	kilograms	inches	mm	
56-802	2.5	1.1	4-3/8	112	4 / 4
56-803	3	1.4	5-1/8	130	4 / 4
56-804	4	1.8	5-1/4	135	4 / 4



CONTRACTOR GRADE™

JACKETED FIBERGLASS HAND DRILLING HAMMERS

Forged steel head — hardened and tempered. Faces machine finished. Yellow colored, jacketed fiberglass handle provides greater visibility, strength and durability.

Product ID No.	—Weight—		—Head Length—		Box/Ctn
	lb.	kilograms	inches	mm	
56-222	2	0.9	3-3/4	95	4 / 4

CONTRACTOR GRADE™

HICKORY HANDLE HAND DRILLING HAMMERS

Forged steel head — hardened and tempered. Faces machine finished. Selected clear lacquered hickory handle.

Product ID No.	—Weight—		—Head Length—		Box/Ctn
	lb.	kilograms	inches	mm	
56-702	2	0.9	3-3/4	95	4 / 4
56-703	3	1.4	4-3/8	111	4 / 4
56-704	4	1.8	4-3/4	121	4 / 4



CONTRACTOR GRADE™

JACKETED FIBERGLASS BLACKSMITH HAMMERS

New England pattern head. Forged from high quality, hardened and tempered steel. Faces are ground and polished. Yellow colored, jacketed fiberglass handle provides greater visibility, strength and durability.

Product ID No.	—Weight—		—Head Length—		Box/Ctn
	lbs.	kilograms	inches	mm	
56-218	2.5	1.1	5	125	4 / 4
56-220	4	1.4	5-1/8	135	4 / 4

CONTRACTOR GRADE™

HICKORY HANDLE BLACKSMITH HAMMERS

New England pattern head. Forged from high quality, hardened and tempered steel. Faces are ground and polished. Selected clear lacquered hickory handle.

Product ID No.	—Weight—		—Head Length—		Box/Ctn
	lbs.	kilograms	inches	mm	
56-412	2.5	1.1	5	125	4 / 4



CONTRACTOR GRADE™

JACKETED FIBERGLASS SLEDGE HAMMERS

Forged steel head — hardened and tempered. Faces machine finished. Yellow colored, jacketed fiberglass handle provides greater visibility, strength and durability.

Product ID No.	—Weight—		—Head Length—		Box/Ctn
	lbs.	kilograms	inches	mm	
56-208	8	3.6	6-1/2	165	4 / 4
56-210	10	4.5	7-1/4	185	4 / 4
56-212	12	5.4	7-3/4	195	4 / 4

CONTRACTOR GRADE™

HICKORY HANDLE SLEDGE HAMMERS

Forged steel head — hardened and tempered. Faces machine finished. Selected clear lacquered hickory handle.

Product ID No.	—Weight—		—Head Length—		Box/Ctn
	lb.	kilograms	inches	mm	
56-806	6	2.7	6-1/8	155	4 / 4
56-808	8	3.6	6-1/2	165	4 / 4
56-810	10	4.5	7-1/4	185	4 / 4
56-812	12	5.4	7-3/4	195	4 / 4
56-816	16	7.3	8-1/2	215	2 / 2



WARNING: WEAR SAFETY GOGGLES USER AND BYSTANDER.



MAGNETIC TACK HAMMER

Forged head, black finish. Polished face, clear lacquered hickory handle. Magnetic tip.

Product ID No.	—O/A Length—		—Weight—		—Head—		Box/Ctn
	in	mm	oz.	grams	in	mm	
54-304	10-1/2	265	5	140	3-3/4	95	6 / 24



SOFT FACE HAMMERS

Replaceable tips are made of tough plastic that won't mar finely finished surfaces. Handles are made of hickory and securely locked in oval eye body. Lacquered handle. Plastic tips are replaceable.

Product ID No.	—Head Weight—		—Handle Length—		Box/Ctn
	oz.	grams	inches	mm	
57-592	1-1/2	40	8	205	6 / 24
57-593	4	110	10-7/8	276	6 / 24
57-594	8	230	12	305	6 / 24
57-595	16	450	13-1/2	343	6 / 24
57-596	32	910	14-1/2	370	2 / 12

SOFT FACE REPLACEMENT TIPS

Soft face tips are marked for identification.



Product ID No.	—Diameter—		Fits Hammer	Box/Ctn
	in	mm		
57-584	1-1/4	32	57-594	6 / 144
57-585	1-3/8	35	57-595	6 / 144



RUBBER MALLET

Tough rubber head molded to a lacquered handle.

Product ID No.	—Overall Length—		—Weight—		Box/Ctn
	in	mm	oz.	grams	
57-522	13-3/4	350	18	510	5 / 5



RIG BUILDERS HATCHET

Strong forged head. Hickory handle. Milled checkered face. **59-140**

CAMP AXE

Heads are forged from high carbon steel and fully heat treated. All axes have fully polished bits and flame finish handles. **59-200, 59-213**

Rig Builders Hatchet

Product ID No.	—Overall Length—		—Cut—		Box/Ctn
	in	mm	in	mm	
59-140	17	445	3-3/4	95	4 / 24

Camp Axe

Product ID No.	Bit	—Head Weight—		—Handle Length—		Box/Ctn
		oz.	grams	inches	mm	
59-200 <i>Camp</i>	Single	1-1/4	0.6	14	355	6 / 6
59-213 <i>Michigan</i>	Single	3-1/2	1.6	36	915	2 / 2

HAMMER HOLSTER

Leather holster with "U" shaped steel loop. Holds hammer within easy reach.



Product ID No.	Box/Ctn
51-900	6 / 36

ALL LEATHER HAMMER HOLSTER

Leather conforms to hammer handle.



Product ID No.	Box/Ctn
51-901	12 / 72

GOGGLES

WORK SAFELY WITH TOOLS BY WEARING SAFETY GOGGLES.

Front and side vision — heavy duty, anti-fog lens. Adjustable head band.



Product ID No.	Box/Ctn
93-060	6 / 24



**COMPO-CAST®
BALL PEIN HAMMERS**

Dead blow steel face ball pein hammer heads are tempered alloy steel with crowned faces for more accuracy — no bounce back. Steel reinforced handle provides added strength and safety, resists breaking on overstrike. Dead blow function uses steel shot.

Product ID No.	—O/A Length—		—Weight—		—Head—		—Face—		Box/Ctn
	in	mm	oz.	grams	in	mm	in	mm	
54-508	11	279	8	227	3-9/16	90	3/4	18	4 / 12
54-512	12	305	12	340	3-13/16	97	7/8	22	4 / 12
54-516	12-5/8	321	16	454	4-1/8	105	1	25	4 / 12
54-524	12-7/8	327	24	680	4-7/16	113	1-3/16	30	2 / 12
54-532	13-5/8	346	32	907	4-3/4	121	1-9/32	32	2 / 12
54-540	16-7/16	417	40	1134	4-3/4	121	1-9/32	32	2 / 12



**COMPO-CAST®
SLIMLINE HEAD SOFT FACE HAMMERS**

Non sparking soft slimline hammers of Uni-Cast™ construction have no exposed metal. Soft faces do not mar surfaces. Do not absorb liquids. Slimline model offers unique profile, ideal for assembly and repair applications in confined areas. Dead blow function uses steel shot. Steel reinforced handle provides added strength and safety, resists breaking on overstrike.

Product ID No.	—O/A Length—		—Weight—		—Head—		—Face—		Box/Ctn
	in	mm	oz.	grams	in	mm	in	mm	
57-540	9-3/8	238	5	142	2-7/8	73	.7	17.5	4 / 12
57-541	10-9/16	268	14	397	4-3/16	106	1.1	27	4 / 12
57-542	12-1/8	308	18	510	4-1/4	108	1.3	33	2 / 12
57-543	12-7/8	327	21	595	5-1/4	133	1.4	35	2 / 12



**COMPO-CAST®
HAND DRILLING / ENGINEER'S HAMMER**

Dead blow steel face hammer heads are tempered alloy steel with crowned faces for more accuracy — no bounce back. Steel reinforced handle provides added strength and safety, resists breaking on overstrike. Dead blow function uses steel shot.

Hand Drilling

Product ID No.	—O/A Length—		—Weight—		—Head—		—Face—		Box/Ctn
	in	mm	oz.	grams	in	mm	in	mm	
56-532	10-7/16	265	32	907	4-3/4	121	1-11/16	43	2 / 12
							1-9/32	33	



**COMPO-CAST®
SLEDGE MODEL SOFT FACE HAMMERS**

Non sparking soft face sledge hammers. Flat area on head allows upright storage. Urethane covering helps reduce noise pollution. Dead blow function uses steel shot. Steel reinforced handle provides added strength and safety, resists breaking on overstrike.

Product ID No.	—O/A Length—		—Weight—		—Head—		—Face—		Box/Ctn
	in	mm	lbs	kilograms	in	mm	in	mm	
57-550	19-5/8	498	5	2.27	7	178	2.5	63	2 / 2
57-551	29-7/8	759	8	3.63	7-1/8	181	2.6	66	2 / 2
57-552	30	762	10.5	4.76	8-1/4	210	3.0	76	2 / 2
57-554	36	914	11.5	5.21	8-1/8	206	3.0	76	2 / 2



**COMPO-CAST®
STANDARD HEAD SOFT FACE HAMMERS**

Non-sparking soft face hammer of Uni-Cast™ construction have no exposed metal. Soft faces do not mar surfaces or equipment. Do not absorb liquids. Dead blow function uses steel shot. Steel reinforced handle provides added strength and safety, resists breaking on overstrike.

Product ID No.	—O/A Length—		—Weight—		—Head—		—Face—		Box/Ctn
	in	mm	oz.	grams	in	mm	in	mm	
57-530	10-1/8	257	10	283	3-1/8	79	1.2	30	4 / 12
57-531	11-1/4	286	18	510	3-3/4	95	1.6	40	4 / 24
57-532	12-7/8	327	21	595	4-1/16	103	1.8	45	4 / 24
57-533	14-1/4	362	42	1,190	4-5/8	117	2.1	53	4 / 12
57-534	15-1/4	387	52	1,473	5-3/8	136	2.5	63	2 / 6



**WARNING: WEAR SAFETY GOGGLES
USER AND BYSTANDER.**

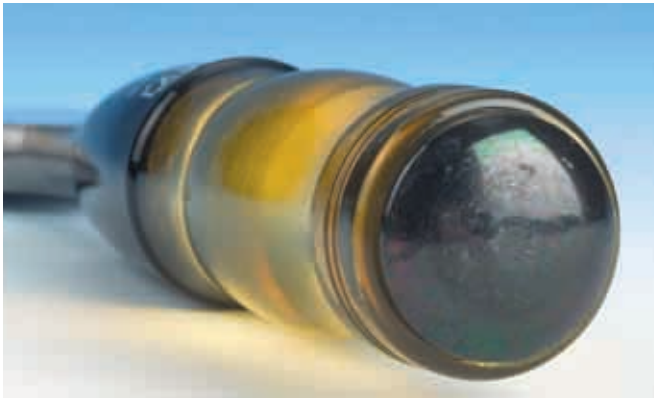

HEAVY-DUTY STRIKE CAPS ARE CROWNED FOR CENTERING BLOWS AND DURABILITY.



900 SERIES WOOD CHISELS

Durable precision-ground cutting edge. Blades are heat treated, beveled and polished. Width identification on handle for quick selection. Blade is forged from high-quality, cutlery grade steel. Extra-long, shatter-resistant handle provides better control and comfort during use.

Product ID No.	—Overall Length—		—Width—		Box/Ctn
	in	mm	in	mm	
16-903	9	228	1/4	6	2 / 24
16-904	9	228	3/8	10	2 / 24
16-905	9	228	1/2	12	2 / 24
16-906	9	228	5/8	16	2 / 24
16-907	9	228	3/4	18	2 / 24
16-908	9	228	1	25	2 / 24
16-909	9	228	1-1/4	32	2 / 24
16-910	9	228	1-1/2	38	2 / 24
16-911	9	228	2	50	2 / 24

900 SERIES 9 Piece Wood Chisel Set

Product ID No.	Contains	—Overall Length—		—Width—		Box/Ctn
		in	mm	in	mm	
16-902	16-903	9	228	1/4	6	1 / 6
	16-904	9	228	3/8	10	
	16-905	9	228	1/2	12	
	16-906	9	228	5/8	16	
	16-907	9	228	3/4	18	
	16-908	9	228	1	25	
	16-909	9	228	1-1/4	32	
	16-910	9	228	1-1/2	38	
	16-911	9	228	2	50	



900 SERIES 6 Piece Wood Chisel Set

Product ID No.	Contains	—Overall Length—		—Width—		Box/Ctn
		in	mm	in	mm	
16-901	12-903	9	228	1/4	6	1 / 6
	12-905	9	228	1/2	12	
	12-907	9	228	3/4	18	
	12-908	9	228	1	25	
	12-909	9	228	1-1/4	32	
	12-910	9	228	1-1/2	38	

900 SERIES 3 Piece Wood Chisel Set

Product ID No.	Contains	—Overall Length—		—Width—		Box/Ctn
		in	mm	in	mm	
16-900	16-905	9	228	1/2	12	1 / 6
	16-907	9	228	3/4	18	
	16-908	9	228	1	25	



CHISEL SAFETY TIPS

- Keep both hands back of the cutting edge at all times when using chisels.
- Always shield the cutting edge when not using.
- Always wear safety goggles when using a wood chisel
- Never place a wood chisel in your pocket.

200 SERIES WOOD CHISEL

Blades are heat treated, beveled and polished. Durable precision ground cutting edge. Blades are forged from high quality cutlery grade steel. Shatter-resistant large amber handle for a comfortable grip.

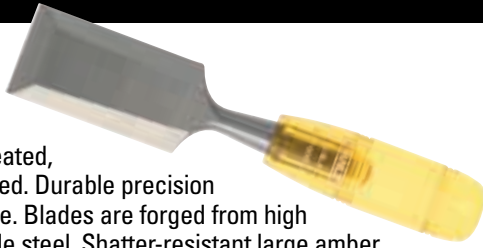

Product ID No.	—Overall Length—		—Width—		Box/Ctn
	in	mm	in	mm	
16-204	7-13/32	188	1/4	6	6 / 24
16-208	7-13/32	188	1/2	12	6 / 24
16-212	7-13/16	198	3/4	18	6 / 24
16-216	7-13/16	198	1	25	6 / 24
16-220	7-13/16	198	1-1/4	32	6 / 24
16-224	7-13/16	198	1-1/2	38	6 / 24

200 SERIES 4 Piece Wood Chisel Set



Product ID No.	Contains	—Overall Length—		—Width—		Box/Ctn
		in	mm	in	mm	
16-200A	16-204	7-13/32	188	1/4	6	1 / 6
	16-208	7-13/32	188	1/2	12	
	16-212	7-13/16	198	3/4	18	
	16-216	7-13/16	198	1	25	

200 SERIES 3 Piece Wood Chisel Set



Product ID No.	Contains	—Overall Length—		—Width—		Box/Ctn
		in	mm	in	mm	
16-180	16-208	7-13/32	188	1/2	12	1 / 6
	16-212	7-13/16	198	3/4	18	
	16-216	7-13/16	198	1	25	

3 PIECE WOOD CHISEL SET

Fully hardened forged blade for re-sharpening. Can be used on hard or soft wood with mallet or hammer. Tough, shock absorbing handle with contoured end to better fit hand.



Product ID No.	Contains	—Overall Length—		—Width—		Box/Ctn
		in	mm	in	mm	
16-150	16-153	7-3/4	199	1/2	12	5 / 30
	16-155	7-3/4	199	3/4	18	
	16-157	7-3/4	199	1	25	

FINE WOODWORKING WOOD GOUGES

Wood gouges range in size from 1/4" to 1" with a finely polished inner surface for shaping, carving and molding various surfaces. These are half rounded, out-cannel gouges, which means that the bevel is ground on the outside of the blade so they're ideal for cutting concave surfaces such as finger pulls for drawers. The select beechwood handles are protected with chromed steel ferrules at the top and bottom.



Product ID No.	—Overall Length—		—Width—		Box/Ctn
	in	mm	in	mm	
16-947	10	254	1/4	6	2 / 20
16-952	10-1/4	260	3/4	18	2 / 20



**WARNING: WEAR SAFETY GOGGLES
USER AND BYSTANDER.**

ELECTRICIAN FLOORING CHISELS

Thin cutting blade for rough cuts. Forged from chrome vanadium steel. Full shank heat treatment.



Product ID No.	—Overall Length—		—Stock Size—		—Cutting Edge—		Box/Ctn
	in	mm	in	mm	in	mm	
18-509	8	203.2	3/4	19.1	2-3/4	69.8	4 / 24
18-511	10-1/2	266.7	5/8	19.9	2-1/2	63.5	4 / 24

BRICK SET

Used for cutting and shaping bricks and blocks. Forged from chrome vanadium steel. Full shank heat treatment.



Product ID No.	—Overall Length—		—Stock Size—		—Cutting Edge—		Box/Ctn
	in	mm	in	mm	in	mm	
18-536	7-1/2	190.5	1	29.4	3-1/2	88.9	4 / 24

COLD CHISELS

Used for cutting metal that is softer than the chisel's cutting edge. Forged from alloy steel, one-piece construction. Hardened and tempered for long life. Blasted finish with rust preventative.



Product ID No.	—Overall Length—		—Stock Size—		—Cutting Edge—		Box/Ctn
	in	mm	in	mm	in	mm	
18-606C	5	127.0	1/4	6.4	1/4	6.4	6 / 24
18-608C	5-1/2	139.7	5/16	7.9	3/8	9.5	6 / 24
18-610C	6	152.4	7/16	11.1	1/2	12.7	6 / 24
18-612C	6-1/2	165.1	1/2	12.7	5/8	15.9	6 / 24
18-615C	7	180.9	5/8	15.9	3/4	19.1	6 / 24
18-621C	8	203.2	7/8	22.2	1	25.4	4 / 4
18-622C	12	304.8	3/4	19.1	1	25.4	4 / 4

3 PIECE COLD CHISEL SET

Durable vinyl pouch for convenient storage or carrying.

Product ID No.	Contains	—Overall Length—		—Stock Size—		—Cutting Edge—		Box/Ctn
		in	mm	in	mm	in	mm	
18-460	18-608	5-1/2	139.7	5/16	7.9	3/8	9.5	2 / 6
	18-610	6	152.4	7/16	11.1	1/2	12.7	
	18-615	7	180.9	5/8	15.9	3/4	19.1	

PIN PUNCHES

Used for removing loosened pins and keys. Forged from alloy steel, one-piece construction. Hardened and tempered for long life. Blasted finish with rust preventative.



Product ID No.	—Overall Length—		—Stock Size—		—Point Size—		Box/Ctn
	in	mm	in	mm	in	mm	
18-628C	4-3/4	120.7	5/16	7.9	1/8	3.2	6 / 24
18-630C	5	127.0	5/16	7.9	5/32	4	6 / 24
18-631C	5-1/4	133.3	3/8	9.5	3/16	4.8	6 / 24

STARTING SOLID PUNCHES

Used for loosening pins and keys or for knocking out rivets. Forged from alloy steel, one-piece construction. Hardened and tempered for long life. Blasted finish with rust preventative.



Product ID No.	—Overall Length—		—Stock Size—		—Point Size—		Box/Ctn
	in	mm	in	mm	in	mm	
18-650C	5	127.0	3/8	9.5	1/8	3.2	6 / 24

PRICK PUNCH

Used for marking metal. Forged from alloy steel, one-piece construction. Hardened and tempered for long life. Blasted finish with rust preventative.



Product ID No.	—Overall Length—		—Stock Size—		—Point Size—		Box/Ctn
	in	mm	in	mm	in	mm	
18-661C	5	127.0	3/8	9.5	5/32	4.0	6 / 24

CENTER PUNCH

Used for marking metal or making indentations for starting drill holes. Forged from alloy steel, one-piece construction. Hardened and tempered for long life. Blasted finish with rust preventative.



Product ID No.	—Overall Length—		—Stock Size—		—Point Size—		Box/Ctn
	in	mm	in	mm	in	mm	
18-665C	4-1/4	107.9	5/16	7.9	5/32	4.0	6 / 24

DRIFT ALIGNING PUNCH

For aligning holes in metal plates or pieces before fastening with rivets, pins, or bolts. Forged from alloy steel, one-piece construction. Hardened and tempered for long life. Blasted finish with rust preventative.



Product ID No.	—Overall Length—		—Stock Size—		—Point Size—		Box/Ctn
	in	mm	in	mm	in	mm	
18-677C	9	228.6	3/8	9.5	5/32	4.0	6 / 24



**CONTRACTOR GRADE™
BOARDBENDER**

■ Designed by builders to straighten deck and joist boards faster and easier. Extra heavy duty, 5/8" high carbon steel bar for extra strength and durability. Cushioned handle designed for kneeling to maintain pressure — frees both hands for nailing. Saves time, money and material.

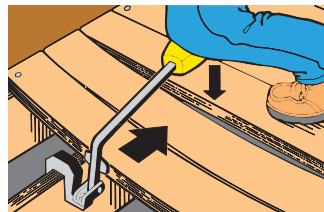

HOOK TOOL ON JOIST. PUSH HANDLE DOWN. BOARDS SQUEEZE TIGHT.

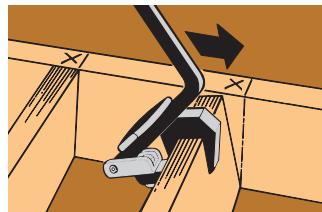

STRAIGHTEN JOISTS.

Product ID No.	Box/Ctn
93-310	2 / 2

**SUPER WONDER BAR®
PRY BAR**

■ Extra long length for extra reach and more leverage. Tightly radiused bend angle for precise positioning. Extra long tongue for better grip and longer reach for hard-to-get-at places. Arch in center of bar gives more swing during nail pulling — no need for a wood block. Works as a panel lift: position pry end under panel, press down radiused end with foot, hands-free operation.

Product ID No.	—Overall Length—		—Blade Width—		Box/Ctn
	inches	mm	inches	mm	
55-525	15-1/2	395	1-3/4	44	0 / 4

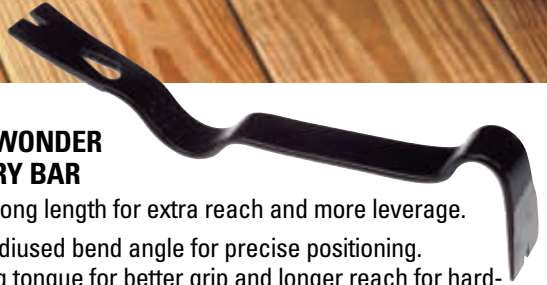

**WONDER BAR®
PRY BAR**

Forged high carbon steel. Heat treated for extra toughness with polished and beveled cutting edges. Contoured bar is ideal for pulling nails, prying, lifting scraping. Beveled nail slot both ends.

Product ID No.	—Overall Length—		—Blade Width—		Box/Ctn
	inches	mm	inches	mm	
55-515	12-3/8	314	1-3/4	44	0 / 4



WARNING: WEAR SAFETY GOGGLES USER AND BYSTANDER.



**WONDER BAR® II
PRY BAR**

Tempered steel with nickel plated finish.

Product ID No.	—Overall Length—		—Blade Width—		Box/Ctn
	inches	mm	inches	mm	
55-045	7	180	7/8	22	6 / 36



NAIL CLAW

Special extracting claw. Heat treated. Beveled nail slot.

Product ID No.	—Overall Length—		—Stock Size—		Box/Ctn
	in	mm	in	mm	
55-033	10	254	9/16	14	6 / 36



NAIL PULLER

Double end puller features 90° and 30° offset claws. Fully sharpened claw tips.

Product ID No.	—Overall Length—		—Stock Size—		Box/Ctn
	in	mm	in	mm	
55-035	11	280	5/8	16	5 / 25



**COMBINATION NAIL
CLAW AND CHISEL**

Combination puller features 90° offset claw and bevel sharpened ripping chisel end.

Product ID No.	—Overall Length—		—Stock Size—		Box/Ctn
	in	mm	in	mm	
55-040	15	380	5/8	16	5 / 25



RIPPING CHISEL

High carbon steel bar. Fully heat treated.

Product ID No.	in	—Stock Size—		—Cutting Edge—		Box/Ctn
		mm	in	mm		
55-146	11/16 x 18	17 x 455	1-1/2	38	0 / 5	



**OFFSET PATTERN
RIPPING CHISEL**

Extra wide claw. Beveled nail slot.

Product ID No.	—Overall Length—		—Stock Size—		—Cutting Edge—		Box/Ctn
	in	mm	in	mm	in	mm	
55-818	17	432	11/16	17	1-11/16	43	5 / 5

A.



B.



**A. FORGED HEXAGONAL
STEEL RIPPING BAR**

High carbon steel for extra strength. Chisel end beveled. Claw and chisel end polished, claw slotted.

Product ID No.	—Size—		Box/Ctn
	inches	mm	
55-112	1/2 x 11	13 x 305	6 / 6
55-118	5/8 x 17	16 x 455	6 / 6
55-124	3/4 x 23	19 x 610	6 / 6
55-130	3/4 x 29	19 x 760	6 / 6
55-136	3/4 x 35	19 x 915	6 / 6

**B. FORGED HEXAGONAL
STEEL RIPPING BAR — GOOSE NECK PATTERN.**

Slotted claw and chisel end. Goose neck pattern.

Product ID No.	—Size—		Box/Ctn
	inches	mm	
55-418	19/32 x 17	15 x 455	6 / 6
55-424	23/32 x 23	18 x 610	6 / 6
55-430	23/32 x 29	18 x 760	6 / 6

Shock absorbing ribbed grip for precision hold.



**CONTRACTOR GRADE™
CUSHION GRIP NAIL SET**

■ Cushioned grip is designed for a non-slip grip in all weather conditions.

Shock absorbing ribbed grip for precision hold. 25% longer length makes it easy to set nails in hidden and “hard-to-reach” areas. Color coded by tip size makes it easy to locate. Fully hardened, precision-milled steel for extra long life. Long beveled tip for easier nail head alignment. Designed by and for the pro. Patent pending.



 *Comfort Grip
Reduced Slip
Reduced Heat/Cold Transfer*

Product ID No.	—Overall Length—		—Tip—		Box/Ctn
	in	mm	in	mm	
58-911 Yellow	5	127	1/32	0.8	6 / 36
58-912 Red	5	127	2/32	1.6	6 / 36
58-913 Gray	5	127	3/32	2.4	6 / 36

3 PIECE CUSHION GRIP NAIL SET

Product ID No.	Contains	—Overall Length—		—Tip—		Box/Ctn
		in	mm	in	mm	
58-930	58-911	5	127	1/32	0.8	6 / 36
	58-912	5	127	2/32	1.6	
	58-913	5	127	3/32	2.4	



NAIL SETS

Square head, round knurled body. Alloy steel hardened and tempered. Tips are cupped and chamfered. Square head prevents rolling.

Product ID No.	—Overall Length—		—Tip—		—Sq. Stock Size—		Box/Ctn
	in	mm	in	mm	in	mm	
58-111	4	100	1/32	.08	5/16	8.0	6 / 72
58-112	4	100	2/32	1.6	5/16	8.0	6 / 72
58-113	4	100	3/32	2.4	5/16	8.0	6 / 72
58-114	4	100	4/32	3.2	5/16	8.0	6 / 72

NAIL SET PACK

Assortment of three nail sets.

Product ID No.	Contains	—Overall Length—		—Tip—		—Sq. Stock Size—		Box/Ctn
		in	mm	in	mm	in	mm	
58-230	58-111	4	101	1/32	.08	5/16	8.0	6 / 72
	58-112	4	101	2/32	1.6	5/16	8.0	
	58-113	4	101	3/32	2.4	5/16	8.0	

SELF-CENTERING NAIL SETS

Engineered for faster positive setting of nails and brads mechanically without marring wood surface. 58-010 sets 16, 17, 18 brads. 58-011 sets 4d and 6d finishing nails. Nickel plated.

Product ID No.	—Overall Length—		—Face Diam.—		Box/Ctn
	in	mm	in	mm	
58-010	2-25/32	70.6	3/8	9.5	6 / 36
58-011	3-5/32	80.2	9/16	14.3	6 / 36

SELF-CENTERING SCREW HOLE PUNCH

Self-centering on hinges, catches, etc. Nickel plated.

Product ID No.	—Overall Length—		—Face Diam.—		Box/Ctn
	in	mm	in	mm	
58-013	3-1/16	77.8	3/8	9.5	6 / 36

CENTER PUNCH

Square head.

Product ID No.	—Overall Length—		—Tip—		—Stock Size—		Box/Ctn
	in	mm	in	mm	in	mm	
58-120	4	100	1/8	3.2	5/16	8.0	6 / 72



**WARNING: WEAR SAFETY GOGGLES
USER AND BYSTANDER.**

Screwdrivers are among the simplest and most universally practical hand tools. Not only are there screwdrivers for every screw-fastening task, they are still preferable in many instances to power drivers. In particular, if a pilot hole is readied for the screw, hand-held screwdrivers are nearly as fast and offer far more control as their powered counterparts. In addition to basic screwdriver designs, tip and handle styles, Stanley® offers a variety of specialty versions, including stubby drivers for close-in areas and offset drivers for superior turning power in the tightest locations.

Stanley® screwdrivers feature forged, heat-treated, rust-resistant steel blades for maximum performance and resiliency, with precision tips in every variety.

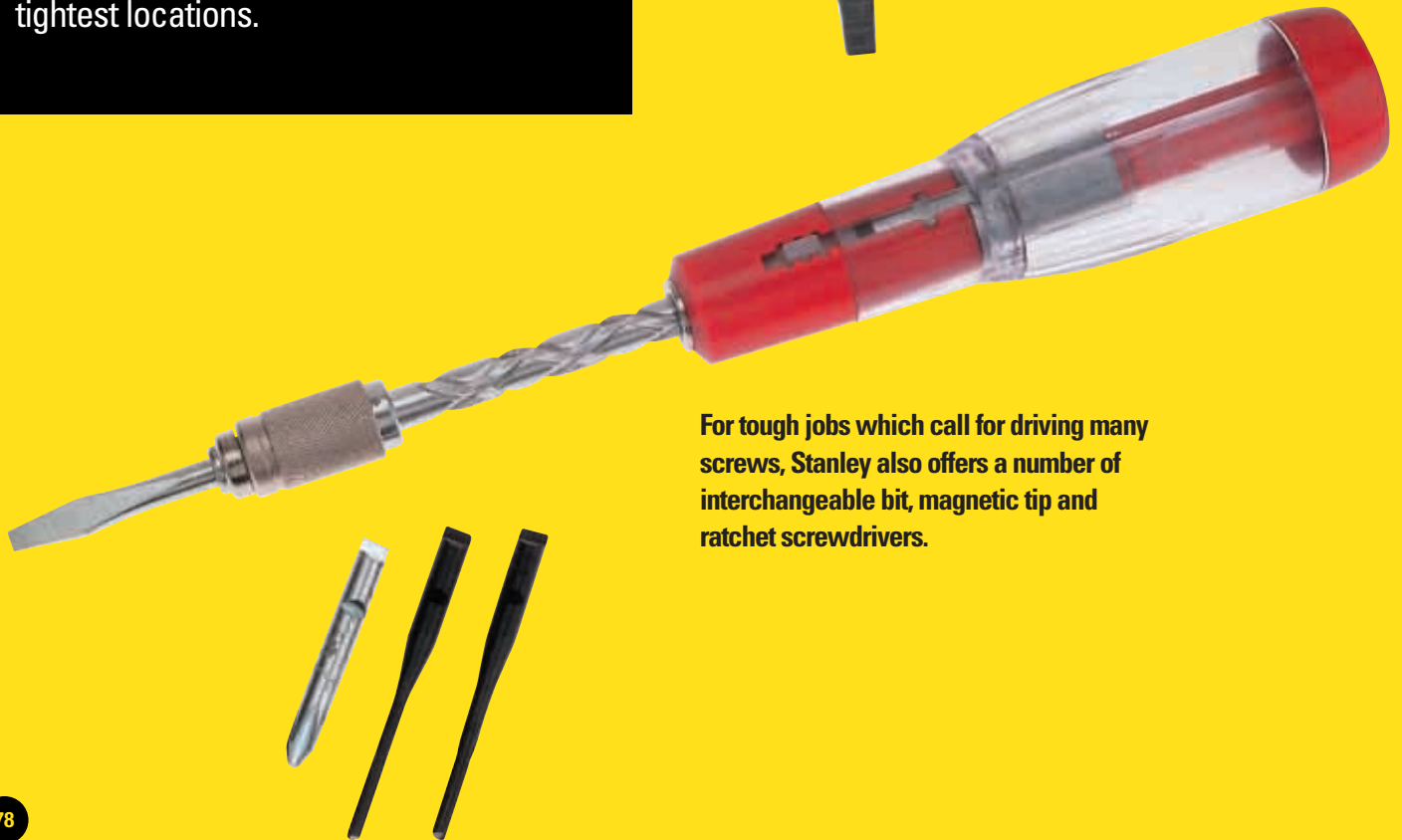

For tough jobs which call for driving many screws, Stanley also offers a number of interchangeable bit, magnetic tip and ratchet screwdrivers.

STANLEY

FASTENING TOOLS

Stanley® Contractor Grade™ full size, vinyl grips provide superior comfort and increased turning power and control.



SCREWDRIVER STYLES



CONTRACTOR GRADE™

Vinyl Grip Screwdrivers

- Full sleeve vinyl grip for comfort and turning force
- Hard plastic core built for strength (and abuse)
- Full size handles for extra gripping power
- Chrome plated for superior corrosion resistance
- Phillips tips are blasted black oxide for precision and to eliminate plate chipping
- Some of the standard tips include a bolster for strength and additional turning capabilities
- 6 pc. set and full open stock available
- Contractor Grade™ packaging identifies this product as being extra tough and durable



CONTRACTOR GRADE™

100 Plus Screwdrivers

- Full size handles
- Alloy steel blade
- Some of the standard tips include a bolster for strength and additional turning capabilities
- Precision-ground tip
- Chrome plated for corrosion resistance



Fluted Screwdrivers

- Two-texture grip for maximum comfort and turning power
- Bigger handles for a better grip
- Color coded handles for easy tip identification
- Nickel plated bars for corrosion resistance

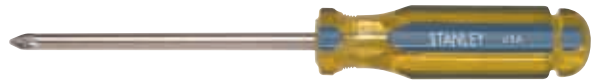

Handyman® Screwdrivers

- Color coded handles for easy tip identification
- Nickel plated for corrosion resistance
- Full open stock and sets



Standard Fluted Screwdrivers

- Nickel plated for corrosion resistance
- Basic Stanley® black and yellow graphics

SCREWDRIVER TIP CONFIGURATIONS



SLOTTED: Standard or flat for driving single slotted screws. Tip width range from 1/6" to 1/2".



PHILLIPS*: Designed specifically for use with Phillips head screw, which has two recessed slots at right angles to each other. Sizes range from 0 point (small) to 4 point (large).



POZIDRIV*: Similar to the Phillips style, the screw can be identified by additional lines on the face. Sizes range from 1 point (small) to 4 point (large).



CLUTCH HEAD: Hour glass tip configuration, used in mobile homes, recreational vehicles and industrial applications. Tips widths range from 5/32" x to 5/16".



SQUARE HEAD: Square tip, used in mobile homes, recreational vehicles and industrial applications. Sizes range from 1 point (small) to 3 point (large).



TORX†: Star shaped, used in the automotive industry. Sizes range from T-10 (small) to T-30 (large).

CONTRACTOR GRADE™ Vinyl Grip Screwdrivers

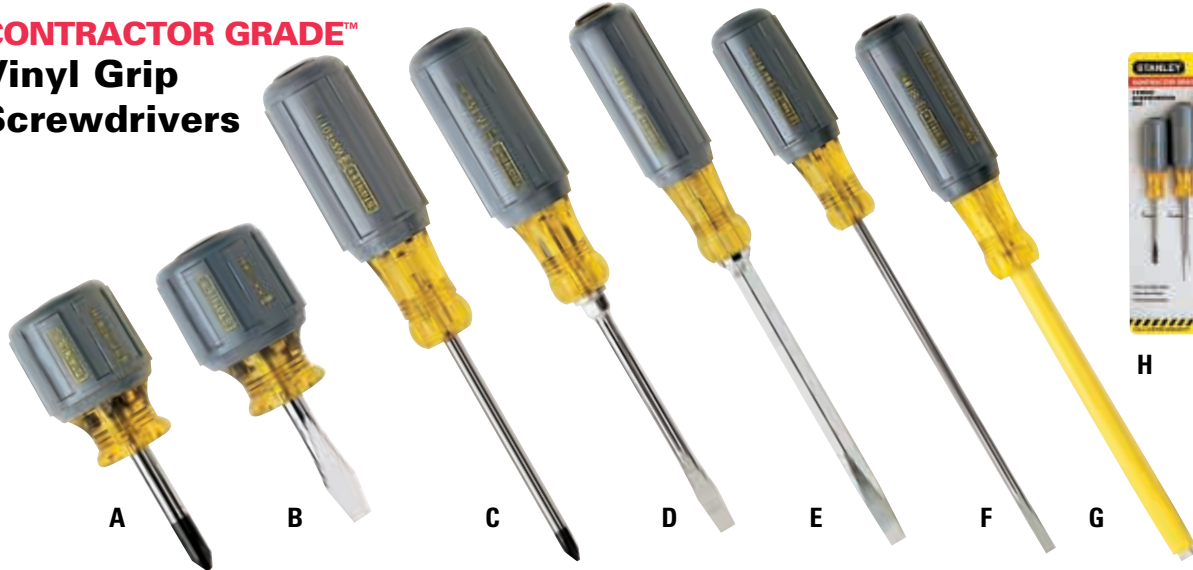

Full size vinyl grip handle. Alloy steel blade. Precision machined black oxide on Phillips* tip. Chrome plated for corrosion resistance.

A. VINYL GRIP PHILLIPS* TIP STUBBY SCREWDRIVER

For close-quarter driving. Precision machined black oxide tip. Alloy steel blade. Chrome plated for corrosion resistance.

Product ID No.	—O/A Length—		—Blade Len.—		—Blade Dia.—		Point Size	Box/Ctn
	in	mm	in	mm	in	mm		
66-905	3-7/8	87	1-1/2	40	1/4	6	2	6 / 36

B. VINYL GRIP STUBBY / STANDARD TIP SCREWDRIVER

For close-quarter driving. Rubber grip handle. Alloy steel blade. Chrome plated for corrosion resistance.

Product ID No.	—O/A Length—		—Blade Len.—		—Blade Dia.—		—Tip Width—		Box/Ctn
	in	mm	in	mm	in	mm	in	mm	
66-088	3-7/16	87	1-1/2	40	1/4	6	1/4	6	6 / 36

C. VINYL GRIP PHILLIPS* TIP SCREWDRIVER

Product ID No.	—O/A Length—		—Blade Len.—		—Blade Dia.—		Point Size	Box/Ctn
	in	mm	in	mm	in	mm		
65-901	6-3/4	170	3	76	3/16	5	1	6 / 36
65-902	6-5/16	211	4	100	1/4	6	2	6 / 36
65-903	10-3/16	277	6	150	5/16	8	3	6 / 36

D. VINYL GRIP STANDARD BLADE/STANDARD TIP SCREWDRIVER

Tips fully cross ground for more secure fit. Chrome plated for corrosion resistance. Bolstered blade for maximum strength.

Product ID No.	—Tip Thick.—		—O/A Length—		—Blade Len.—		—Blade Dia.—		—Tip Width—		Box/Ctn
	in	mm	in	mm	in	mm	in	mm	in	mm	
66-089	.032	0.8	6-3/4	170	3	76	7/32	5.5	7/32	5.5	6 / 36
66-090	.037	0.9	8-1/4	210	4	102	1/4	6	1/4	6	6 / 36
66-091	.042	1.1	10-5/16	277	6	152	5/16	8	5/16	8	6 / 24
66-092	.050	1.3	13-3/8	340	8	200	3/8	10	3/8	10	6 / 24

E. VINYL GRIP SQUARE BLADE/STANDARD TIP SCREWDRIVER

Tips fully cross ground for more secure fit. Chrome plated for corrosion resistance. Bolstered blade for maximum strength.

Product ID No.	—O/A Length—		—Blade Len.—		—Blade Dia.—		—Tip Width—		Box/Ctn
	in	mm	in	mm	in	mm	in	mm	
66-093	8-1/4	210	4	102	1/4	6	1/4	6	6 / 36
66-094	10-5/16	277	6	152	5/16	8	5/16	8	6 / 24
66-095	10-5/16	277	8	203	3/8	10	3/8	10	6 / 24

F. VINYL GRIP LIGHT BLADE / CABINET TIP SCREWDRIVER

Product ID No.	—O/A Length—		—Blade Len.—		—Blade Dia.—		—Tip Width—		Box/Ctn
	in	mm	in	mm	in	mm	in	mm	
66-096	6-3/4	170	3	76	3/16	5	3/16	5	6 / 36
66-097	9-3/4	248	6	152	3/16	5	3/16	5	6 / 36
66-098	11-3/4	298	8	200	3/16	5	3/16	5	6 / 24

G. VINYL GRIP VINYL COATED BLADE SCREWDRIVER

CAUTION: Never depend on a driver's handle or covered blade to insulate you from electricity. Vinyl-coated blades are intended only as a protective measure against shorting-out components.

Product ID No.	—O/A Length—		—Blade Len.—		—Blade Dia.—		—Tip Width—		Box/Ctn
	in	mm	in	mm	in	mm	in	mm	
66-894	8-1/16	204	3-3/4	95	1/4	6	1/4	6	6 / 36

H. VINYL GRIP 6 PIECE SCREWDRIVER SET

Product ID No.	Contains		Box/Ctn
66-565	4" Standard 6" Standard 3" Cabinet 6" Cabinet 1 pt. Phillips* 2 pt. Phillips*		6 / 6

*PHILLIPS registered trademark of Phillips Screw Co.

†TORX registered trademark of Textron, Inc.

*POZIDRIVE registered trademark of Camcar Division of Textron, Inc.

**CONTRACTOR GRADE™
100 Plus® Screwdrivers**



Full size handles. Alloy steel blade. Precision-ground tip. Chrome plated for corrosion resistance.

A. 100 PLUS® STANDARD BLADE / STANDARD TIP SCREWDRIVER

Bolster blade for maximum strength.

Product ID No.	—O/A Length—		—Blade Len.—		—Blade Dia.—		—Tip Width—		Box/Ctn
	in	mm	in	mm	in	mm	in	mm	
66-163	6-3/4	170	3	76	7/32	5.5	7/32	5.5	6 / 36
66-164	8-1/4	210	4	102	1/4	6	1/4	6	6 / 36
66-166	11	280	6	152	5/16	8	5/16	8	6 / 24
66-011	10-1/4	260	6	152	1/4	6	1/4	6	6 / 24
66-168	13-1/4	336	8	200	3/8	10	3/8	10	6 / 24
66-013	13	330	8	200	5/16	8	5/16	8	6 / 24
66-160	15-1/4	387	10	254	3/8	10	3/8	10	6 / 24
66-162	17-1/4	438	12	305	3/8	10	3/8	10	6 / 24

B. 100 PLUS® SQUARE BLADE / STANDARD TIP SCREWDRIVER

Bolster blade for maximum strength.

Product ID No.	—O/A Length—		—Blade Len.—		—Blade Dia.—		—Tip Width—		Box/Ctn
	in	mm	in	mm	in	mm	in	mm	
66-015	6-3/4	170	3	76	3/16	5	3/16	5	6 / 36
66-018	8-3/4	210	4	102	3/16	5	3/16	5	6 / 36
66-174	8-3/4	210	4	102	1/4	6	1/4	6	6 / 36
66-176	11	280	6	152	5/16	8	5/16	8	6 / 24
66-178	13-1/4	336	8	200	3/8	10	3/8	10	6 / 24
66-170	15-1/4	387	10	254	3/8	10	1/2	13	6 / 24
66-172	17-1/4	438	12	305	3/8	10	1/2	13	6 / 24

C. 100 PLUS® STUBBY SCREWDRIVER

Product ID No.	—O/A Length—		—Blade Len.—		—Blade Dia.—		—Tip Width—		Box/Ctn
	in	mm	in	mm	in	mm	in	mm	
66-161	3-1/2	90	1-1/2	40	1/4	6	1/4	6	6 / 36

D. 100 PLUS® PHILLIPS™ TIP SCREWDRIVER

Product ID No.	—O/A Length—		—Blade Len.—		—Blade Dia.—		Point Size	Box/Ctn
	in	mm	in	mm	in	mm		
64-100	5-1/8	130	2-3/4	70	1/8	3	0	6 / 72
64-101	6-3/4	130	3	76	3/16	5	1	6 / 72
64-102	8-1/4	210	4	102	1/4	6	2	6 / 36
64-103	11	280	6	152	5/16	8	3	6 / 24
64-104	13-1/4	336	8	200	3/8	1	4	6 / 24
64-171	13-1/2	343	10	254	3/16	5	1	6 / 24
64-172	14-1/2	368	10	254	1/4	6	2	6 / 24
64-175	24-1/4	616	20	508	1/4	6	2	6 / 6

E. 100 PLUS® PHILLIPS TIP STUBBY SCREWDRIVER

Product ID No.	—O/A Length—		—Blade Len.—		—Blade Dia.—		Point Size	Box/Ctn
	in	mm	in	mm	in	mm		
64-105	3-1/2	90	1-1/2	40	1/4	6	2	6 / 36

F. 100 PLUS® STANDARD BLADE / CABINET TIP SCREWDRIVER

Product ID No.	—O/A Length—		—Blade Len.—		—Blade Dia.—		—Tip Width—		Box/Ctn
	in	mm	in	mm	in	mm	in	mm	
66-183	6-3/4	170	3	76	3/16	5	3/16	5	6 / 36
66-186	11-3/4	298	6	152	3/16	5	3/16	5	6 / 36
66-188	11-3/4	298	8	200	3/16	5	3/16	5	6 / 36
66-180	13-3/4	349	10	254	3/16	5	3/16	5	6 / 24
66-182	15-3/4	400	12	305	3/16	5	3/16	5	6 / 24

G. 100 PLUS® EXTRA LIGHT BLADE / CABINET TIP SCREWDRIVER

Designed for precision screw driving applications. Contoured amber handle designed to fit comfortably in the hand for delicate work. Tips are heat treated for high strength for radio, TV and the electronics industry.

Product ID No.	—O/A Length—		—Blade Len.—		—Blade Dia.—		—Tip Width—		Box/Ctn
	in	mm	in	mm	in	mm	in	mm	
66-112	5-3/8	136	2	50	1/8	3	1/8	3	6 / 36
66-113	6-3/8	160	3	76	1/8	3	1/8	3	6 / 36
66-114	7-3/8	187	4	102	1/8	3	1/8	3	6 / 36
66-116	9-3/8	238	6	152	1/8	3	1/8	3	6 / 36
66-118	11-3/8	340	8	200	1/8	3	1/8	3	6 / 36
66-110	13-3/8	340	10	224	1/8	3	1/8	3	6 / 36

CONTRACTOR GRADE™ 100 Plus® Screwdrivers



H. 100 PLUS® POCKET SCREWDRIVER

Pocket clip. Practical for light work.

Product ID No.	—O/A Length—		—Blade Len.—		—Blade Dia.—		—Tip Width—		Box/Ctn
	in	mm	in	mm	in	mm	in	mm	
66-101	4-3/8	110	2	50	1/8	3	1/8	3	12 / 72
66-102	5-3/8	110	3	76	3/32	2.4	3/32	2	6 / 36
66-103	6-3/8	162	4	102	3/32	2.4	3/32	2	6 / 36
64-170	4-3/8	110	2	50	1/8	3	0 pt. Phillips		6 / 36

I. 100 PLUS® POZIDRIV® SCREWDRIVER

Designed to fit Pozidriv screws. Black oxide finish on blade. Used in automotive, aircraft, electronic and appliance businesses.

Product ID No.	—O/A Length—		—Blade Len.—		—Blade Dia.—		Point Size	Screw Size	Box/Ctn
	in	mm	in	mm	in	mm			
64-131	6-3/4	170	3	76	3/16	5	1	2-4	6 / 72
64-132	8-1/4	210	4	102	1/4	6	2	5-10	6 / 36
64-133	11	280	6	152	5/16	8	3	12-1/4	6 / 24
64-134	13-1/4	337	8	208	3/8	10	4	5/16-3/8	6 / 36

J. 100 PLUS® SQUARE HEAD STYLE SCREWDRIVER

Designed to fit square head style screws. Chrome plated to resist rust. Commonly used in mobile homes, boat construction and the hobby industry.

Blade Tips Made For Stanley in Canada.

Product ID No.	—O/A Length—		—Blade Len.—		—Blade Dia.—		Point Size	Box/Ctn
	in	mm	in	mm	in	mm		
64-422	8-1/4	210	4	102	1/4	6	2	6 / 36

Product ID No.	Screw Capacity		Self-Tapping Screws
	Wood Screws	Machine Screws	
64-422	8, 9, 10	8, 10	8, 10

K. 100 PLUS® SCRATCH AWL

Bolstered blade, reinforced construction.

Product ID No.	—O/A Length—		—Blade Len.—		—Blade Dia.—		Box/Ctn
	in	mm	in	mm	in	mm	
69-006	7-1/4	184	3-1/2	89	1/4	6	6 / 36

SCREWDRIVER SAFETY TIPS

- Never use a screwdriver as a cold chisel, or for prying, punching, chiseling, scoring or scraping.
- Make sure the tip fits the slot of the screw; not too loose or tight.
- Never expose a screwdriver to excessive heat or cold.
- Always discard a screwdriver with a worn or broken handle.
- Never use a screwdriver on a workpiece held in your hand. A slip could cause serious injury.
- Never depend on a screwdrivers' handle or covered blade to insulate you from electricity. Vinyl covered blades are intended only as a protective measure against shorting out components.



*PHILLIPS registered trademark of Phillips Screw Co.

†TORX registered trademark of Textron, Inc.

•POZIDRIV registered trademark of Camcar Division of Textron, Inc.



**Fluted
Screwdrivers**

Two-textured handle for extra turning power even when your hand is sweaty or greasy. Color coded handles make it easy to find the right tip for the job. Nickel plated for corrosion resistance.

**FLUTED STANDARD TIP
SCREWDRIVER**

Product ID No.	—O/A Length—		—Blade Len.—		—Blade Dia.—		—Tip Width—		Box/Ctn
	in	mm	in	mm	in	mm	in	mm	
69-422 <i>Pocket clip</i>	4-3/8	111	2	51	1/8	3	1/8	3	6 / 36
69-424	8-1/4	210	4	102	1/4	6	1/4	6	6 / 36
69-426	10-1/4	260	6	152	1/4	6	1/4	6	6 / 36
69-427	10-5/8	270	6	152	5/16	8	5/16	8	6 / 36
69-428	12-5/8	321	8	203	5/16	8	5/16	8	6 / 36

**FLUTED STUBBY / STANDARD TIP
SCREWDRIVER**

Product ID No.	—O/A Length—		—Blade Len.—		—Blade Dia.—		—Tip Width—		Box/Ctn
	in	mm	in	mm	in	mm	in	mm	
69-425	3-21/32	93	1-1/2	38	1/4	6	1/4	6	6 / 36

**FLUTED CABINET TIP
SCREWDRIVER**

Product ID No.	—O/A Length—		—Blade Len.—		—Blade Dia.—		—Tip Width—		Box/Ctn
	in	mm	in	mm	in	mm	in	mm	
69-413	7-1/4	184	3	76	3/16	5	3/16	5	6 / 36
69-416	10-1/4	260	6	152	3/16	5	3/16	5	6 / 36
69-418	12-1/4	311	8	203	3/16	5	3/16	5	6 / 36

**FLUTED PHILLIPS® TIP
SCREWDRIVER**

Product ID No.	—O/A Length—		—Blade Len.—		—Blade Dia.—		Point Size	Box/Ctn
	in	mm	in	mm	in	mm		
69-410 <i>Pocket clip</i>	4-3/8	111	2	51	1/8	3	0	6 / 36
69-401	8-1/4	210	4	102	3/16	5	1	6 / 36
69-402	8-1/4	210	4	102	1/4	6	2	6 / 36
69-403	10-5/8	270	6	152	5/16	8	3	6 / 36

**FLUTED STUBBY PHILLIPS TIP
SCREWDRIVER**

Product ID No.	—O/A Length—		—Blade Len.—		—Blade Dia.—		Point Size	Box/Ctn
	in	mm	in	mm	in	mm		
69-405	3-21/32	93	1-1/2	38	1/4	6	2	6 / 36

**FLUTED TORX†
SCREWDRIVER**

Product ID No.	—O/A Length—		—Blade Len.—		—Blade Dia.—		Torx Size	Box/Ctn
	in	mm	in	mm	in	mm		
69-430	7-1/2	191	3-1/4	83	3/16	5	T10	6 / 36
69-431	7-1/2	191	3-1/4	83	3/16	5	T15	6 / 36
69-432	7-1/2	191	3-1/4	83	3/16	5	T20	6 / 36
69-433	8-1/4	210	4	102	3/16	5	T25	6 / 36
69-434	8-1/4	210	4	102	1/4	6	T30	6 / 36

FLUTED SCRATCH AWL / ICE PICK

Product ID No.	—O/A Length—		—Blade Len.—		—Blade Dia.—		Box/Ctn
	in	mm	in	mm	in	mm	
69-435	8-1/4	210	4	102	5/32	4	6 / 36

FLUTED TACK CLAW

Product ID No.	—O/A Length—		—Blade Len.—		—Blade Dia.—		Box/Ctn
	in	mm	in	mm	in	mm	
69-436	7-7/8	200	3-5/8	92	1/4	6	6 / 36



FLUTED SCREWDRIVER SETS

Product ID No.	Contains	Box/Ctn
69-453 <i>3 Pc. Set</i>	4" Standard, 1 Pt. and 2 Pt. Phillips	0 / 6
69-455 <i>5 Pc. Set</i>	4" and 6" Standard, 3" Cabinet 1 Pt. and 2 Pt. Phillips	0 / 6
69-457 <i>7 Pc. Set</i>	4" and 6" Standard, Standard Tip Stubby 3" Cabinet, 1 Pt. and 2 Pt. Phillips, Phillips Stubby	0 / 6
69-458 <i>8 Pc. Tube Set</i>	4" and 6" Standard, 3" and 6" Cabinet, 1 Pt. and 2 Pt. Phillips, Standard Pocket, 0 pt. Phillips Pocket	0 / 15

Handyman® Screwdrivers

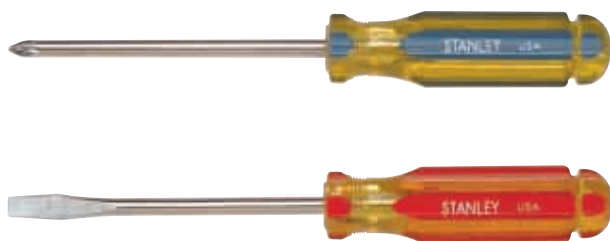

Color coded handles for easy tip identification. Nickel plated for corrosion resistance. Handles shaped for a comfortable grip. Tips sized for a more secure fit in screw slot.

HANDYMAN® STANDARD BLADE / STANDARD TIP SCREWDRIVERS

Product ID No.	—O/A Length—		—Blade Len.—		—Blade Dia.—		—Tip Width—		Box/Ctn
	in	mm	in	mm	in	mm	in	mm	
64-864	8-1/8	206	4	102	3/8	8	1/4	6	6 / 72
64-866	10-3/16	259	6	150	5/16	8	5/16	8	6 / 72
64-896	10-1/8	257	6	150	1/4	6	1/4	6	6 / 36
64-868	13	330	8	200	5/16	8	3/8	10	6 / 24

HANDYMAN® STANDARD STUBBY SCREWDRIVER

Product ID No.	—O/A Length—		—Blade Len.—		—Blade Dia.—		—Tip Width—		Box/Ctn
	in	mm	in	mm	in	mm	in	mm	
64-842	3-1/2	90	1-1/2	40	1/4	6	1/4	6	6 / 36

HANDYMAN® SQUARE BLADE / STANDARD TIP SCREWDRIVERS

Product ID No.	—O/A Length—		—Blade Len.—		—Blade Dia.—		—Tip Width—		Box/Ctn
	in	mm	in	mm	in	mm	in	mm	
64-874	8-1/2	206	4	102	1/4	6	1/4	6	6 / 72
64-876	8-1/2	206	6	152	5/16	8	5/8	16	6 / 72

HANDYMAN® PHILLIPS* TIP SCREWDRIVERS

Product ID No.	—O/A Length—		—Blade Len.—		—Blade Dia.—		Point Size	Box/Ctn
	in	mm	in	mm	in	mm		
65-320	4-3/8	111	2	51	1/8	3	0	6 / 36
65-321	7-1/2	190	4	102	3/16	5	1	6 / 36
65-322	8-1/8	206	4	102	1/4	6	2	6 / 36
65-323	10-3/16	258	6	152	5/16	8	3	6 / 36

HANDYMAN® STUBBY PHILLIPS* TIP SCREWDRIVER

Product ID No.	—O/A Length—		—Blade Len.—		—Blade Dia.—		Point Size	Box/Ctn
	in	mm	in	mm	in	mm		
65-342	3-1/2	90	1-1/2	40	1/4	6	2	6 / 36

HANDYMAN® POCKET SCREWDRIVER

Product ID No.	—O/A Length—		—Blade Len.—		—Blade Dia.—		—Tip Width—		Box/Ctn
	in	mm	in	mm	in	mm	in	mm	
64-840	4-1/2	108	2	50	1/8	3	1/8	3	6 / 72

HANDYMAN® LIGHT BLADE / CABINET TIP SCREWDRIVERS

Product ID No.	—O/A Length—		—Blade Len.—		—Blade Dia.—		—Tip Width—		Box/Ctn
	in	mm	in	mm	in	mm	in	mm	
64-883	6-3/4	172	3	76	3/16	5	3/16	5	6 / 72
64-886	9-3/4	248	6	152	3/16	5	3/16	5	6 / 72

HANDYMAN® EXTRA LIGHT BLADE / CABINET TIP SCREWDRIVER

Product ID No.	—O/A Length—		—Blade Len.—		—Blade Dia.—		—Tip Width—		Box/Ctn
	in	mm	in	mm	in	mm	in	mm	
64-846	6-1/4	159	4	102	1/8	3	1/8	3	6 / 36

HANDYMAN® CLUTCH HEAD SCREWDRIVERS

Designed for general service work. Tip end milled heat treated and accurately sized for secure grip. Black oxide finish.

Product ID No.	—O/A Length—		—Blade Length—		—Clutch Size—		Box/Ctn
	in	mm	in	mm	in	mm	
64-950	7-1/8	181	3	76	5/32	4	6 / 36
64-951	8-1/8	206	4	102	3/16	5	6 / 36

HANDYMAN® SQUARE TIP SCREWDRIVER

Designed for Robertson style recessed screws found in mobile homes, boat construction and hobby industry.

Product ID No.	—O/A Length—		—Blade Length—		Point Size	Box/Ctn
	in	mm	in	mm		
64-961	7-3/4	196	4	102	1	6 / 36
64-964	7-3/4	196	4	102	2	6 / 36

HANDYMAN® TORX† SCREWDRIVER

Developed to meet industry's demand for a more reliable fastening system. Virtually eliminates slipping screw head distortion and driver wear. Black oxide blade and tip. Commonly used in automotive applications.

Product ID No.	—O/A Length—		—Blade Len.—		—Blade Dia.—		Torx Size	Box/Ctn
	in	mm	in	mm	in	mm		
64-551	7-3/8	187	3-1/4	83	3/16	5	T10	6 / 36
64-552	7-3/8	187	3-1/4	83	3/16	5	T15	6 / 36
64-553	7-3/8	187	3-1/4	83	3/16	5	T20	6 / 36
64-554	8-1/8	206	4	102	3/16	5	T25	6 / 36
64-556	8-1/8	206	4	102	1/4	6	T30	6 / 36

HANDYMAN® TACK CLAW

Hardened steel blade has tempered steel claw. Tough handle has full size grip with deep flutes.

Product ID No.	—O/A Length—		—Blade Len.—		—Blade Dia.—		Box/Ctn
	in	mm	in	mm	in	mm	
69-010	7-3/8	187	3-5/8	92	1/4	6	6 / 36

*PHILLIPS registered trademark of Phillips Screw Co.

†TORX registered trademark of Textron, Inc.

•POZIDRIV registered trademark of Camcar Division of Textron, Inc.

**Handyman®
Screwdrivers**



64-077



64-710



64-856



64-557



64-854

Color coded handles for easy tip identification. Nickel plated for corrosion resistance. Handles shaped for a comfortable grip. Tips sized for a more secure fit in screw slot.

**HANDYMAN® 20 PIECE
SCREWDRIVER SET**

Product ID No.	Contains	Box/Ctn
64-077	4" and 6" Standard 3" and 6" Cabinet Standard Stubby 2" Pocket 0 Pt. Phillips Pocket 2 Pt. Phillips Stubby T15 and T20 Torx 1 Pt., 2 Pt., 3 Pt. Phillips Scratch Awl / Ice Pick Tack Claw Keychain Eyeglass 4" Instrument Standard and Phillips Offset Phillips Offset	0 / 12

**HANDYMAN® 10 PIECE
SCREWDRIVER SET**

A versatile screwdriver set to satisfy most of your fastening needs. Features the 10 most popular sizes. Heat treated alloy steel ensures long screwdriver life. Large comfortable handles.

Product ID No.	Contains	Box/Ctn
64-710	2" Pocket Clip Slotted Stubby Phillips Stubby 4" and 6" Standard 3" and 6" Cabinet 0 Pt, 1 Pt, 2 Pt. Phillips	6 / 6

**HANDYMAN® 8 PIECE
SCREWDRIVER SET**

Product ID No.	Contains	Box/Ctn
64-708	4" and 6" Standard 3" and 6" Cabinet 1 Pt. and 2 Pt. Phillips Stubby Standard Stubby Phillips	12 / 12

**HANDYMAN® 6 PIECE
SCREWDRIVER SET**

Product ID No.	Contains	Box/Ctn
64-856	4" and 6" Standard 3" and 6" Cabinet 1 Pt. and 2 Pt. Phillips	6 / 6

**HANDYMAN® 4 PIECE TORX®
SCREWDRIVER SET**

Developed to meet industry's demand for a more reliable fastening system. Virtually eliminates slipping screw head distortion and driver wear. Black oxide blade and tip. Commonly used in automotive applications.

Product ID No.	Contains	Box/Ctn
64-557	T15 T20 T25 T30	6 / 6

**HANDYMAN® 4 PIECE
SCREWDRIVER SET**

Product ID No.	Contains	Box/Ctn
64-854	4" Standard 3" Cabinet 1 Pt., and 2 Pt. Phillips	6 / 6

**HANDYMAN® 2 PIECE
SCREWDRIVER SET**

Product ID No.	Contains	Box/Ctn
64-843	Standard Pocket 0 Pt. Phillips Pocket	6 / 36



STANDARD FLUTED STANDARD BLADE / STANDARD TIP SCREWDRIVERS

Plastic handles for comfortable grip. Alloy steel nickel protected blades for long life. Hardened tips for non-slip fit.

Product ID No.	—O/A Length—		—Blade Len.—		—Blade Dia.—		—Tip Width—		Box/Ctn
	in	mm	in	mm	in	mm	in	mm	
64-461	6-5/8	193	6	152	1/4	6	1/4	6	10 / 100
64-462	7-5/8	193	4	102	1/4	6	1/4	6	6 / 36



STANDARD FLUTED PHILLIPS* TIP SCREWDRIVERS

Plastic handles for comfortable grip. Alloy steel nickel protected blades for long life. Hardened tips for non-slip fit.

Product ID No.	—O/A Length—		—Blade Len.—		—Blade Dia.—		Point Size	Box/Ctn
	in	mm	in	mm	in	mm		
64-465	7-5/8	193	4	102	3/16	5	1	10 / 100
64-466	7-5/8	193	4	102	1/4	6	2	10 / 100



STANDARD FLUTED LIGHT BLADE / CABINET TIP SCREWDRIVERS

Plastic handles for comfortable grip. Alloy steel nickel protected blades for long life. Hardened tips for non-slip fit.

Product ID No.	—O/A Length—		—Blade Len.—		—Blade Dia.—		—Tip Width—		Box/Ctn
	in	mm	in	mm	in	mm	in	mm	
64-464	6-5/8	168	3	76	3/16	5	3/16	5	10 / 100
64-463	9-5/8	244	6	152	3/16	5	3/16	5	10 / 100

STANDARD FLUTED 15 PIECE SCREWDRIVER SET

Product ID No.	Contains	Box/Ctn
64-016	6" x 1/4" Standard 6" x 5/16" Standard 4" Standard Standard Stubby 6" and 3" Cabinet 1 Pt., 2 Pt., 3 Pt. Phillips Stubby Phillips 2" x 0 Pt. Phillips 2" x 1/8" Standard Keychain Scratch Awl / Ice Pick Screw Hole Starter	12 / 12

STANDARD FLUTED 10 PIECE SCREWDRIVER SET

Versatile screwdriver set to satisfy most of your fastening needs. Features 10 popular sizes. Heat treated alloy steel ensures long life. Large, comfortable handles.

Product ID No.	Contains	Box/Ctn
64-010	4" and 6" Standard 3" and 6" Cabinet 0 Pt., 1 Pt., 2 Pt. Phillips, 2" x 1/8" Standard Standard Stubby Stubby Phillips	12 / 12



64-016



64-010



64-457



64-415L



64-454



64-302

STANDARD FLUTED 6 PIECE SCREWDRIVER SET

Product ID No.	Contains	Box/Ctn
64-457	4" and 6" Standard 3" and 6" Cabinet 1 Pt. and 2 Pt. Phillips*	12 / 12

STANDARD FLUTED 5 PIECE SCREWDRIVER SET

Product ID No.	Contains	Box/Ctn
64-415L	6" Standard Standard Stubby 3" Cabinet 1 Pt. and 2 Pt. Phillips	24 / 24

STANDARD FLUTED 4 PIECE SCREWDRIVER SET

Product ID No.	Contains	Box/Ctn
64-454	6" Standard 3" Cabinet 1 Pt. and 2 Pt. Phillips	12 / 12

STANDARD FLUTED 2 PIECE SCREWDRIVER SET

Product ID No.	Contains	Box/Ctn
64-302	4" Standard 2 Pt. Phillips	4 / 24

HIGH VISIBILITY SCREWDRIVER SETS

High visibility color makes it easy to find in a tool box, cabinet, pouch, etc. Large durable handles for comfort and torque. Alloy steel, nickel plated blades for long life. Hardened tips for non-slip fit.



Product ID No.	Contains	Box/Ctn
64-003 4 piece set	6" Standard 3" Cabinet 1 Pt. and 2 Pt. Phillips	12 / 12
64-001 2 piece set	4" Standard 2 Pt. Phillips	24 / 24

2 PIECE TORX[®] SCREWDRIVER SET

Nickel plated for corrosion resistance. Durable handle for long life.



Product ID No.	Contains	Box/Ctn
64-024	T15 T-20	6 / 36

6 PIECE JEWELERS SCREWDRIVER SET

Six precision screwdrivers feature swivel-head handles. Bright plated shafts fluted for better grip. Hardened and tempered steel blades with blued finish to resist corrosion. Plastic storage case to index tools.



Product ID No.	Contains	Box/Ctn
66-039	0 pt. and 1 pt. Phillips 1.4mm Slotted 1.8mm Slotted 2.3mm Slotted 3.0mm Slotted	1 / 36

4-WAY[™] SCREWDRIVER

Four tips in one tool — 3/16" and 1/4" slotted bit, 1 Pt. and 2 Pt. Phillips* bit. Triangular shaped handle with plated barrel to resist rust. 1/4" hex bits are protected with rust resistant finish.

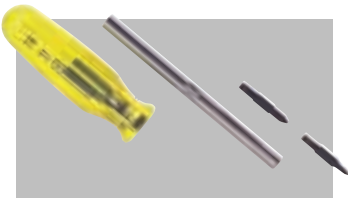

Product ID No.	Contains	—OA Length—		Box/Ctn
		in	mm	
66-401	3/16", 1/4" Slotted 1 Pt., 2 Pt. Phillips	7-3/4	197	6 / 72

ECONOMY 4-WAY[™] SCREWDRIVER

Four tips in one tool — 3/16" and 1/4" slotted bit, 1 Pt. and 2 Pt. Phillips bit. Tri-fluted handle. Plated barrel resists rust.



Product ID No.	Contains	—O/A Length—		Box/Ctn
		in	mm	
66-405C	3/16", 1/4" Slotted 1 Pt., 2 Pt. Phillips	7-3/4	197	6 / 72

5 PIECE MAGNETIC TIP SCREWDRIVER

Five screwdrivers in one—3/16" and 9/32" slotted, 1 Pt. and 2 Pt. Phillips and T-15 Torx* bits. Triangular shaped, easy-open snap cap handle stores all five bits. Aluminum magnetic shank with forged head resists rust and provides extra strength. Rust resistant bits are specially heat treated for long life.



Product ID No.	Contains	—O/A Length—		Box/Ctn
		in	mm	
66-801	3/16", 9/32" Slotted 1 Pt., 2 Pt. Phillips T-15 Torx*	8-3/8	213	6 / 72

5 PIECE RATCHET SCREWDRIVER

Features three position ratchet screwdriver with convenient bit storage in handle.



Product ID No.	Contains	Box/Ctn
68-750	3/16", 1/4" 9/32" Slotted 1 Pt., 2 Pt. Phillips	6 / 6

4-WAY[™] 1/4" HEX DOUBLE ENDED BITS

Hardened for use in hand or power tools. Rust resistant finish.



Product ID No.	—Bit Size—		Box/Ctn
	Slotted	Phillips	
66-415	3/16", 1/4"	#1, #2	6 / 36

14 PIECE RATCHET SCREWDRIVER SET

Features three position ratchet screwdriver with convenient storage in handle.

Product ID No.	Contains	Box/Ctn
68-753	3/16", 1/4", 9/32" Slotted 1 Pt., 2 Pt. Phillips, 1/4" Drive Adapters with 3/16", 1/4", 5/16", 11/32", 3/8", 7/16" 1/2" Sockets Convenient Reusable Storage Case	4 / 4



26 PIECE RATCHET SCREWDRIVER SET

Features three position ratchet screwdriver with convenient storage in handle.

Product ID No.	Contains	Box/Ctn
68-754	3/16", 1/4", 9/32" Slotted 1 Pt., 2 Pt. Phillips T10, T15, T20, T25, T30 Torx 1/4" Drive Socket Adapters with 3/16", 1/4", 5/16", 11/32", 3/8", 7/16", 1/2", 6mm, 7mm, 8mm, 9mm, 10mm, 11mm, 12mm Sockets Convenient Reusable Storage Case.	2 / 2



YANKEE® SPIRAL RATCHET SCREWDRIVER

Quick-return style. Furnished with two bits and two drill points. Transparent plastic handle with convenient storage. All exposed bright metal parts are plated.



Product ID No.	Bits		Drill Pt. Size	Length w/		Box/Ctn
	Width of Tip			Bit Closed	Bit Extended	
68-233	2 Pt. 5/32	4	7/64 9/64	2.8 3.5	9-1/2 241 7-3/8 187	3 / 24

TAP WRENCH WITH YANKEE® RATCHET

Product ID No.	Tap Cap.		O/A Length		Box/Ctn
	in	mm	in	mm	
68-251	1/4	6	3-1/2	89	1 / 12



FINE WOODWORKING YANKEE® SPIRAL RATCHETING SCREWDRIVER

Stanley offers a line of Yankee® Spiral Ratcheting Screwdrivers in several lengths. These are time and labor savers for craftsmen in all fields. The three-position ratchets work in the forward, reverse and fixed blade positions. The spirals are spring loaded to keep the blade in the screw slot and automatically returns the handle into the driving position after each stroke. Each model is furnished with two bits.



Product ID No.	Bits		Length w/		Length w/		Box/Ctn
	Width of Tip		Bit Extended		Bit Closed		
68-130	2 Pt., 1/4	6	19-3/8	492	15	381	4 / 24
68-131	2 Pt., 1/4	6	28	711	20	508	4 / 24
68-135	2 Pt., 3/16	5	12-1/2	317	9-3/4	248	1 / 6



YANKEE® DRILL POINT SET

For use with 68-135, 68-233 drivers.

Product ID No.	Contains	Box/Ctn
68-333	5/64", 7/64", 9/64" Drill Points	12 / 72

YANKEE® ACCESSORY PACK AND DRILL POINT SET

Replacement bits and drill points for Yankee® driver 68-233.

Product ID No.	Contains	Box/Ctn
68-330	5/32" Slotted 2 Pt. Phillips 5/64", 7/64", 9/64" Drill Points	6 / 72

YANKEE® RATCHET SCREWDRIVER BITS

Replacement bits for Phillips* recessed head screws.

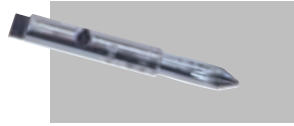

Product ID No.	—O/A Length—		For Driver	Point Size	Box/Ctn
	in	mm			
68-377	1-3/4	45	68-135, 68-233	1	6 / 72
68-371	3	76	68-030, 68-130, 68-130B	1	6 / 72
68-372	3	76	68-135, 68-233	2	6 / 72

PHILLIPS OFFSET SCREWDRIVER

For 1 Pt. and 2 Pt. Phillips* screws.



Product ID No.	—O/A Length—		—Blade Diam.—		Point Size	Box/Ctn
	in	mm	in	mm		
65-032	3-15/16	99	1/4	6	1, 2	6 / 72

OFFSET PHILLIPS/SLOTTED SCREWDRIVER

For 1/4" slotted and 2 Pt. Phillips* screws.



Product ID No.	—O/A Length—		—Blade Diam.—		Box/Ctn
	in	mm	in	mm	
65-033	3-15/16	99	1/4	6	6 / 72

1/4" INSERT BITS 5 PIECE TORX® T SET

Assortment of 1/4" Hex Torx® bits made of hardened and tempered alloy steel for durability and strength. Rust resistant finish.



Product ID No.	Contains	Box/Ctn
68-722	T10, T15, T20, T25, T30	6 / 36

YANKEE® OFFSET RATCHETS

Slotted / Phillips* Screwdriver

For 1/4" slotted and 2 point Phillips* screws.



Product ID No.	—O/A Length—		—Blade Length—		Point Size	Box/Ctn
	in	mm	in	mm		
68-402	3-7/8	98	1/4	6	2	6 / 72

Slotted Screwdriver

For 1/4" slotted and 3/8" slotted screws. Two different size blades are special alloy steel, hardened and tempered.

Product ID No.	—O/A Length—		— Blade Length —		Box/Ctn
	in	mm	Small	Large	
68-400	3-7/8	98	1/4 (6)	3/8 (10)	6 / 72

Phillips* Screwdrivers

For Phillips* head screws. Points are hardened and tempered.

Product ID No.	—O/A Length—	Point Size	Box/Ctn
	in mm		
68-412	3-7/8 98	1, 2	6 / 72

HEX KEY SET

Short arm hex keys are made of heat treated alloy steel with black penetrate finish to resist rust. Keys are stamped with sizes conforming to industry standards and meet federal specifications. Packed in snap flap pouch with screw applications printed on the back side.



Product ID No.	Size of Keys Included	Box/Ctn
69-207 7 pc. English	5/64, 3/32, 1/8, 5/32, 3/16, 7/32, 1/4"	10 / 40
69-211 11 Pc. English	.050, 1/16, 5/64, 3/32, 1/8, 5/32, 3/16, 7/32, 1/4, 5/16, 3/8"	10 / 40
69-215 15 Pc. English Set.	.028, .035, .050, 1/16, 5/64, 3/32, 7/64, 1/8, 9/64, 5/32, 3/16, 7/32, 1/4, 5/16, 3/8"	10 / 40

FOLDING HEX KEY SET

Keys fold neatly and securely into convenient storage case. Heat treated alloy steel for longer tool life.

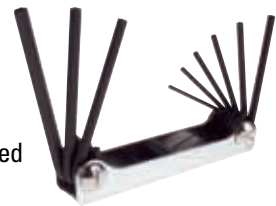

Product ID No.	Size of Keys Included	Box/Ctn
69-216 8 Pc. English	.050, 1/16, 5/64, 3/32, 7/64, 1/8, 9/64, 5/32"	6 / 120
69-217 9 Pc. English	5/64, 3/32, 7/64, 1/8, 9/64, 5/32, 3/16, 7/32, 1/4"	6 / 120
69-218 7 Pc. Metric	1.5, 2, 2.5, 3, 4, 5, 6 mm	6 / 120

SCREW HOLE STARTER

Marks, starts, threads the hole for screw to enter. Plastic handle with full size comfortable grip and a heat tempered blade for long life. The point bites fast and clean at the exact spot screw is to be placed while the hole is threaded for easy entry and turning of the screw.



Product ID No.	—O/A Length—	Box/Ctn
	in mm	
69-008	6-1/2 163	10 / 100

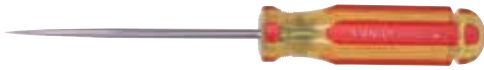

SCRATCH AWL / ICE PICK

Hardened steel blade has tempered steel point. Tough handle provides comfortable, full size grip.

Product ID No.	—O/A Length—		—Blade Length—		Box/Ctn
	in	mm	in	mm	
69-003	7-1/2	190	4	10	6 / 36



ONE PIECE WOOD HANDLE SCRATCH AWL

One piece shank and handle. Blade, shank and head forged from one piece of alloy steel. Rivet through ferrule, handle and shank. Flat sides on handle prevent rolling. Rust resistant plated finish.

Product ID No.	—O/A Length—		—Bar Dia.—		—Bar Length—		Box/Ctn
	in	mm	in	mm	in	mm	
69-007	6-1/4	158	1/4	6	3-1/2	79	6 / 36



WOOD HANDLE SCRATCH AWL

Alloy steel bar anchored in hardwood handle by two wings swaged on the shank. Bar finished bright and smooth. Rust resistant plated finish.

Product ID No.	—O/A Length—		—Bar Dia.—		—Bar Length—		Box/Ctn
	in	mm	in	mm	in	mm	
69-122	6-1/16	154	3/16	5	3-3/8	86	6 / 72



PRO NUT DRIVER

True professional nut drivers combine extra long handle with hollow shaft bars for the most demanding applications.

Product ID No.	Hex Size	Box/Ctn
61-805	3/16	6 / 36
61-806	1/4	6 / 36
61-807	5/16	6 / 36
61-808	11/32	6 / 36
61-809	3/8	6 / 36
61-810	7/16	6 / 36
61-811	1/2	6 / 36

6 PIECE PRO NUT DRIVER SET

True professional nut drivers combine extra large handle with hollow shaft bars for the most demanding applications.

Product ID No.	Hex Size	Box/Ctn
61-825	3/16	4 / 4
	1/4	
	5/16	
	11/32	
	3/8	
	7/16	



NUT DRIVER

Solid one-piece construction nut driver. Bar plated to resist rust.

Product ID No.	Hex Size	Box/Ctn
61-161	1/4	6 / 36
61-162	5/16	6 / 36
61-164	3/8	6 / 36



5 PIECE NUT DRIVER SET

Solid one-piece construction nut drivers. Bar plated to resist rust.

Product ID No.	Hex Size	Box/Ctn
61-160	1/4	0 / 12
	5/16	
	11/32	
	3/8	
	7/16	



SCREWSTART™ TOOL

Holds, starts, removes hard-to-reach screws. Spring loaded tip holds screw firmly, starts and seats screw, then releases automatically. Use Stanley Screwdriver to tighten or loosen screws. Magnet at back end for retrieving screws and other small metal parts. Convenient clip for storage in shirt pocket.

Product ID No.	—O/A Length—	Box/Ctn
	in	mm
69-155 Standard Tip	5-3/16	131
		6 / 72



CLIP'N GRIP™ SCREW HOLDER

Three stainless steel screw holding attachments (3/16", 1/4", and 5/16") that fit round bar screwdrivers. Ideal for automotive and electronic type applications.

Product ID No.	Box/Ctn
69-300	6 / 36

*PHILLIPS registered trademark of Phillips Screw Co.
†TORX registered trademark of Textron, Inc.
•POZIDRIV registered trademark of Camcar Division of Textron, Inc.

Stanley manufactures virtually every mechanics and holding hand tool imaginable, from ratchets, sockets and sets of every size to wrenches, pliers, clamps and more. Each Stanley tool has been designed to exacting standards to provide a lifetime of exceptional performance. Professional and do-it-yourselfers alike will appreciate the ease of use and quick direction changes afforded by Stanley's patented Flip-Drive® straight and flex-head ratchets. Also available are versatile adjustable wrenches and pipe wrenches for heavy-duty work, plus a complete offering of tempered steel, rubber grip pliers of every variety.

Stanley® socket sets are designed with a wide range of sockets and drive tools to meet most assembly applications.



Stanley® makes a range of specialized holding tools and accessories, such as web clamps, spring clamps, and saw horse brackets.



STANLEY

MECHANICS/HOLDING TOOLS

With a wide range of chrome vanadium and alloy steel constructed sockets and accessories, Stanley® has the drive tools to stand up to the torque of any task.



Using end-user feedback and hands-on experience, we set up to develop the best line of tool pouches available in the marketplace. Designed to meet the rigorous demands of today's professionals, our line includes features like the industry's only 5" padded belt, which reduces the likelihood of back fatigue. By placing the pouches on the side and rear of the belt, we have virtually eliminated accidental tool spillage.

1/4" DRIVE TOOLS, SOCKETS AND ACCESSORIES

Stanley Professional™ 1/4" Drive Tools and Sockets are made from chrome vanadium and alloy steel for added strength and durability. They are designed and manufactured to work on smaller fasteners typically found in electronics, auto dashboards and light assembly operations. Manufactured in accordance with ANSI Specifications B107.

1/4" DRIVE QUICK-RELEASE RATCHET

Quick release mechanism for easy removal and attachment of sockets. Comfortable full polish handle — professional appearance. Strong hot forged one piece handle of alloy steel. Fine tooth ratcheting action for use in tight spots; as little as 8° degrees of handle “swing space” is needed to operate.

87-820

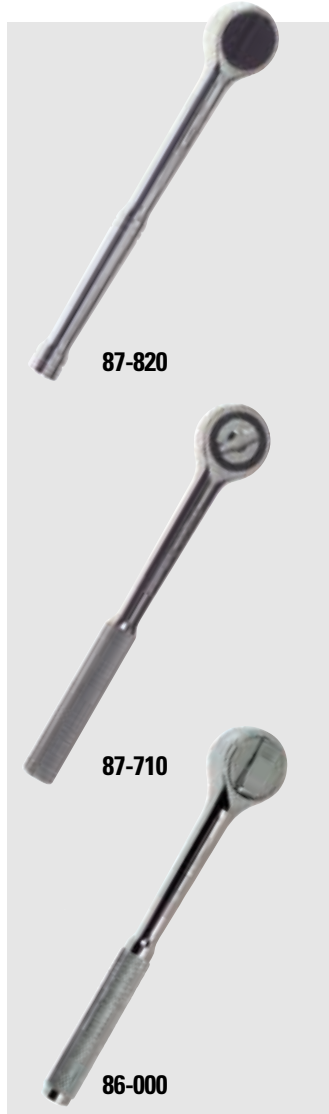

1/4" DRIVE STANDARD RATCHET

Diamond-knurled non-slip hand grip. Strong hot forged one piece handle of alloy steel. Fine tooth ratcheting action for use in tight spots; as little as 8° of handle “swing space” is needed to operate.

87-710

1/4" DRIVE RATCHET

Features Stanley's patented Flip-Drive® shift mechanism. Allows the user to shift direction easily with one hand.

86-000

Product ID No.	Length in inches	Box/Ctn
87-820	6	2 / 12
87-710	6	2 / 12
86-000	6	2 / 12

1/4" DRIVE SPINNER



Converts 1/4" drive sockets into a set of nutdrivers. Useful in auto dashboards and small appliance repair.

Product ID No.	Length in inches	Box/Ctn
86-004	6	3 / 24

1/4" DRIVE EXTENSIONS



Attach to handles and sockets for reaching hard to get at fasteners. Chrome finish protects against corrosion and wear.

Product ID No.	Length in inches	Box/Ctn
86-006	3	3 / 24
86-007	6	3 / 24

1/4" DRIVE UNIVERSAL JOINT



Product ID No.	Box/Ctn
86-011	3 / 24

1/4" DRIVE SOCKET CLIP RAIL SET



Holds up to 16 sockets. Made from alloy steel for strength and durability.

Product ID No.	Length in inches	Box/Ctn
87-018	17	4 / 12

1/4" DRIVE 6 POINT STANDARD SOCKETS



Product ID No.	Opening in inches	Length in inches	Box/Ctn
86-021	5/32	13/16	3 / 24
86-022	3/16	13/16	3 / 24
86-023	7/32	13/16	3 / 24
86-024	1/4	13/16	3 / 24
86-025	9/32	13/16	3 / 24
86-026	5/16	13/16	3 / 24
86-027	11/32	13/16	3 / 24
86-028	3/8	13/16	3 / 24
86-029	7/16	13/16	3 / 24
86-030	1/2	13/16	3 / 24

1/4" DRIVE 6 POINT DEEP SOCKETS

Product ID No.	Opening in inches	Length in inches	Box/Ctn
86-043	1/4	2	3 / 24
86-044	9/32	2	3 / 24
86-045	5/16	2	3 / 24
86-046	11/32	2	3 / 24
86-047	3/8	2	3 / 24
86-048	7/16	2	3 / 24
86-049	1/2	2	3 / 24



1/4" DRIVE 6 POINT STANDARD METRIC SOCKETS

Product ID No.	Opening in mm	Length in inches	Box/Ctn
86-101	4	13/16	3 / 24
86-102	5	13/16	3 / 24
86-103	6	13/16	3 / 24
86-104	7	13/16	3 / 24
86-105	8	13/16	3 / 24
86-106	9	13/16	3 / 24
86-107	10	13/16	3 / 24
86-108	11	13/16	3 / 24
86-109	12	13/16	3 / 24



WARNING: Do not use chrome sockets on impact tools. Tool damage and bodily injury may result. Disconnect electrical appliances before making repairs.

3/8" DRIVE TOOLS, SOCKETS AND ACCESSORIES

Stanley Professional™ 3/8" Drive Tools and Sockets are available in a wide range of sizes and shapes to fit most fastening applications. The sockets are available in both inch and metric sizes, standard or deep lengths. Made from chrome vanadium and alloy steel for added strength and durability. Manufactured in accordance with ANSI Specifications B107.

3/8" DRIVE QUICK RELEASE RATCHET

Quick release mechanism for easy removal and attachment of sockets. Comfortable full polish handle — professional appearance. Strong hot forged one piece handle of alloy steel. Fine tooth ratcheting action for use in tight spots; as little as 8° of handle "swing space" is needed to operate.

87-830

3/8" DRIVE STANDARD RATCHET

Diamond-knurled non-slip hand grip. Strong hot forged one piece handle of alloy steel. Fine tooth ratcheting action for use in tight spots; as little as 8° of handle "swing space" is needed to operate.

87-715

3/8" DRIVE FLEX HEAD RATCHET

Offset handle and pivoting head give extra clearance working in tight spaces on and around engines. Patented Flip-Drive® shift mechanism.

86-201

3/8" DRIVE RATCHET

Features Stanley's patented Flip-Drive® shift mechanism. Allows the user to shift direction easily with one hand.

86-200



Product ID No.	Length in inches	Box/Ctn
87-830	8	2 / 12
87-715	8	2 / 12
86-201	10-1/2	2 / 12
86-200	8	2 / 12



**WARNING: WORK SAFELY WITH TOOLS
WEAR SAFETY GOGGLES.**

3/8" DRIVE EXTENSIONS



Product ID No.	Length in inches	Box/Ctn
86-206	3	3 / 24
86-207	6	3 / 24
86-208	10	3 / 24

3/8" DRIVE UNIVERSAL JOINT



Product ID No.	Length in inches	Box/Ctn
86-211	2	3 / 24

3/8" DRIVE SPEEDER



Product ID No.	Length in inches	Box/Ctn
86-212	8-1/2	2 / 12

3/8" DRIVE FLEX HANDLE



Product ID No.	Length in inches	Box/Ctn
86-213	15	2 / 12

3/8" DRIVE ADAPTER



Product ID No.	Length in inches	Size in inches	Box/Ctn
86-214	1	3/8F x 1/4M	3 / 24
86-215	1-3/8	3/8F x 1/2M	3 / 24

3/8" DRIVE 3-WAY TOOL



Another Stanley® innovation. Six inch extension and special 3/8" F x 1/4" M adapter can be used separately or combined as a sliding T-handle for use on smaller fasteners.

Product ID No.	Length in inches	Box/Ctn
86-216	6	2 / 12

3/8" DRIVE BEAM STYLE TORQUE WRENCH

For tightening fasteners to precise torque levels. Dual scale reads 0-800 inch-pounds and 0-90 Newton Meters.



Product ID No.	Length in inches	Box/Ctn
86-383	13-1/2	1 / 12

3/8" DRIVE SOCKET CLIP RAIL

Holds up to 16 sockets. Made from alloy steel for strength and durability.



Product ID No.	O/A Length in inches	Box/Ctn
87-019	17	4 / 12

3/8" DRIVE 6 POINT STANDARD SOCKETS



Product ID No.	Opening in inches	Length in inches	Box/Ctn
86-262	3/8	1	3 / 24
86-263	7/16	1	3 / 24
86-264	1/2	1	3 / 24
86-265	9/16	1	3 / 24
86-266	5/8	1-1/8	3 / 24
86-267	11/16	1-1/8	3 / 24
86-268	3/4	1-1/8	3 / 24
86-269	13/16	1-1/8	3 / 24
86-270	7/8	1-1/8	3 / 24

3/8" DRIVE 6 POINT DEEP SOCKETS



Product ID No.	Opening in inches	Length in inches	Box/Ctn
86-281	3/8	1-3/4	3 / 24
86-282	7/16	1-3/4	3 / 24
86-283	1/2	1-3/4	3 / 24
86-284	9/16	2	3 / 24
86-285	5/8	2-1/8	3 / 24
86-286	11/16	2-1/4	3 / 24
86-287	3/4	2-1/4	3 / 24
86-288	13/16	2-1/2	3 / 24



3/8" DRIVE 6 POINT STANDARD METRIC SOCKETS

Product ID No.	Opening in mm	Length in inches	Box/Ctn
86-302	7	1	3 / 24
86-303	8	1	3 / 24
86-304	9	1	3 / 24
86-305	10	1	3 / 24
86-306	11	1	3 / 24
86-307	12	1	3 / 24
86-308	13	1	3 / 24
86-309	14	1	3 / 24
86-310	15	1	3 / 24
86-311	16	1	3 / 24
86-312	17	1-1/8	3 / 24
86-313	18	1-1/8	3 / 24
86-314	19	1-1/8	3 / 24



3/8" DRIVE 6 POINT DEEP METRIC SOCKETS

Product ID No.	Opening in mm	Length in inches	Box/Ctn
86-322	10	1-3/4	3 / 24
86-323	11	1-3/4	3 / 24
86-324	12	1-3/4	3 / 24
86-325	13	1-3/4	3 / 24
86-326	14	2	3 / 24
86-327	15	2-1/8	3 / 24
86-328	17	2-1/4	3 / 24
86-329	19	2-1/4	3 / 24



3/8" DRIVE SPARK PLUG SOCKETS

Product ID No.	Opening in inches	Length in inches	Box/Ctn
86-380	5/8	2-1/2	3 / 24
86-381	13/16	2-3/4	3 / 24

WARNING: Do not use chrome sockets on impact tools. Tool damage and bodily injury may result. Disconnect electrical appliances before making repairs.

1/2" DRIVE TOOLS, SOCKETS AND ACCESSORIES

Stanley Professional™ 1/2" Drive Tools, Sockets and Accessories are designed to stand up to the higher torque requirements frequently found in larger fasteners. Made from chrome vanadium and alloy steel for added strength and durability. Manufactured in accordance with ANSI Specifications B107.

1/2" DRIVE QUICK-RELEASE RATCHET

Quick release mechanism for easy removal and attachment of sockets. Comfortable full polish handle — professional appearance. Strong hot forged one piece handle of alloy steel. Fine tooth ratcheting action for use in tight spots; as little as 8° of handle “swing space” is needed to operate.

87-840

1/2" DRIVE STANDARD RATCHET

Diamond-knurled non-slip hand grip. Strong hot forged one piece handle of alloy steel. Fine tooth ratcheting action for use in tight spots; as little as 8° of handle “swing space” is needed to operate.

87-720

1/2" DRIVE RATCHET

Features Stanley's patented Flip-Drive® shift mechanism. Allows the user to shift direction easily with one hand.

86-400



Product ID No.	Length in inches	Box/Ctn
87-840	10	2 / 12
87-720	10	2 / 12
86-400	10	2 / 12

1/2" DRIVE EXTENSIONS



Product ID No.	Length in inches	Box/Ctn
86-406	2-1/2	3 / 24
86-407	5	3 / 24
86-408	10	3 / 24



**WARNING: WORK SAFELY WITH TOOLS
WEAR SAFETY GOGGLES.**

1/2" DRIVE UNIVERSAL JOINT



Product ID No.	Length in inches	Box/Ctn
86-411	2-3/4	3 / 24

1/2" DRIVE SPEEDER



Product ID No.	Length in inches	Box/Ctn
86-412	16	2 / 12

1/2" DRIVE FLEX HANDLE



Product ID No.	Length in inches	Box/Ctn
86-413	16	2 / 12

1/2" DRIVE ADAPTER



Allows the use of 3/8" sockets with 1/2" drive tools.

Product ID No.	Length in inches	Size in inches	Box/Ctn
86-414	1-3/8	1/2F x 3/8M	3 / 24

1/2" DRIVE BEAM STYLE TORQUE WRENCH

For tightening larger fasteners to specified torque levels. Dual scale read 0-150 foot pounds and 0-200 Newton Meters.



Product ID No.	Length in inches	Box/Ctn
86-583	16-3/8	1 / 12

1/2" DRIVE SOCKET CLIP RAIL

Holds up to 16 sockets. Made from alloy steel for strength and durability.



Product ID No.	Length in inches	Box/Ctn
87-020	17	4 / 12

1/2" DRIVE 12 POINT STANDARD SOCKETS



Product ID No.	Opening in inches	Length in inches	Box/Ctn
86-461	3/8	1-1/2	3 / 24
86-462	7/16	1-1/2	3 / 24
86-463	1/2	1-1/2	3 / 24
86-464	9/16	1-1/2	3 / 24
86-465	5/8	1-1/2	3 / 24
86-466	11/16	1-1/2	3 / 24
86-467	3/4	1-1/2	3 / 24
86-468	13/16	1-1/2	3 / 24
86-469	7/8	1-1/2	3 / 24
86-470	15/16	1-1/2	3 / 24
86-471	1	1-5/8	3 / 24
86-472	1-1/16	1-3/4	3 / 24
86-473	1-1/8	1-3/4	3 / 24
86-474	1-1/4	1-3/4	3 / 24

1/2" DRIVE 12 POINT DEEP SOCKETS



Product ID No.	Opening in inches	Length in inches	Box/Ctn
86-481	1/2	3-1/8	3 / 24
86-482	9/16	3-1/8	3 / 24
86-483	5/8	3-1/8	3 / 24
86-484	11/16	3-1/8	3 / 24
86-485	3/4	3-1/8	3 / 24
86-486	13/16	3-1/8	3 / 24
86-487	7/8	3-1/8	3 / 24
86-488	15/16	3-1/8	3 / 24
86-489	1	3-1/8	3 / 24
86-490	1-1/16	3-1/8	3 / 24
86-491	1-1/8	3-1/8	3 / 24

1/2" DRIVE 12 POINT STANDARD METRIC SOCKETS



Product ID No.	Opening in mm	Length in inches	Box/Ctn
86-544	12	1-1/2	3 / 24
86-545	13	1-1/2	3 / 24
86-546	14	1-1/2	3 / 24
86-547	15	1-1/2	3 / 24
86-548	16	1-1/2	3 / 24
86-549	17	1-1/2	3 / 24
86-550	18	1-1/2	3 / 24
86-551	19	1-1/2	3 / 24
86-553	21	1-1/2	3 / 24
86-554	22	1-1/2	3 / 24
86-556	24	1-1/2	3 / 24
86-557	27	1-5/8	3 / 24
86-559	30	1-5/8	3 / 24

1/2" DRIVE SPARK PLUG SOCKETS

For use on most auto, truck, boat, snowmobile and lawnmower spark plugs. Rubber insert protects plug insulator and prevents plug from dropping.



Product ID No.	Opening in mm	Length in inches	Box/Ctn
86-580	5/8	2-1/2	3 / 24
86-581	13/16	2-3/4	3 / 24

1/2" DRIVE IMPACT TOOLS, SOCKETS

Stanley® Impact sockets are designed to withstand the higher torque and force encountered from air and electric powered impact tools. Manufactured from special alloy steel, then heat treated, they provide the perfect balance of strength, hardness, and durability. Black oxide finish for corrosion resistance.



1/2" DRIVE IMPACT 6 PT. STANDARD SOCKETS

Product ID No.	Opening in inches	Length in inches	Box/Ctn
87-515	9/16	1-1/2	3 / 24
87-516	5/8	1-1/2	3 / 24
87-517	11/16	1-1/2	3 / 24
87-519	13/16	1-1/2	3 / 24
87-520	7/8	1-1/2	3 / 24
87-522	1	1-1/2	3 / 24

Metric Sockets

Product ID No.	Opening in mm	Length in inches	Box/Ctn
87-500	13	1-1/2	3 / 24
87-501	14	1-1/2	3 / 24
87-502	15	1-1/2	3 / 24
87-503	16	1-1/2	3 / 24
87-504	17	1-1/2	3 / 24
87-505	18	1-1/2	3 / 24
87-507	21	1-1/2	3 / 24
87-508	22	1-1/2	3 / 24
87-509	24	1-1/2	3 / 24
87-510	27	1-1/2	3 / 24



SOCKET SETS

Stanley® Socket Sets are designed with a wide range of sockets and drive tools to meet most assembly applications. The metal box sets include a durable plastic tray to protect and organize the set components.



**1/4" DRIVE
10 PIECE STANDARD CLIP RAIL INCH SOCKET SET**

Product ID No.	Packed	6 Point Socket Sizes	Box/Ctn
87-745	Carded	5/32, 3/16, 7/32, 1/4, 9/32, 5/16, 11/32, 3/8, 7/16, 1/2,	2 / 12

Metric Socket Set

Product ID No.	Packed	6 Point Socket Sizes	Box/Ctn
87-746	Carded	4mm, 5mm, 6mm, 7mm, 8mm, 9mm, 10mm, 11mm, 12mm, 13mm	2 / 12



**1/4" DRIVE
7 PIECE DEEP CLIP RAIL INCH SOCKET SET**

Product ID No.	Packed	Sockets 6 Points Deep	Box/Ctn
87-747	Carded	1/4, 9/32, 5/16, 11/32, 3/8, 7/32, 1/2,	2 / 12



**3/8" DRIVE
8 PIECE STANDARD CLIP RAIL INCH SOCKET SET**

Product ID No.	Packed	6 Point Socket Sizes	Box/Ctn
87-748	Carded	3/8, 7/16, 1/2, 9/16, 5/8, 11/16, 3/4, 13/16	2 / 12



**3/8" DRIVE
10 PIECE STANDARD CLIP RAIL METRIC SOCKET SET**

Product ID No.	Packed	6 Point Socket Sizes	Box/Ctn
87-749	Carded	10mm, 11mm, 12mm, 13mm, 14mm, 15mm, 16mm, 17mm, 18mm, 19mm	2 / 12



**3/8" DRIVE
8 PIECE DEEP CLIP RAIL INCH SOCKET SET**

Product ID No.	Packed	Sockets 6 Points Deep	Box/Ctn
87-750	Carded	3/8, 7/16, 1/2, 9/16, 5/8, 11/16, 3/4, 13/16	2 / 12



**3/8" DRIVE
5 PIECE HEX BIT CLIP RAIL SOCKET SET**

Product ID No.	Packed	Hex Bit Sockets	Box/Ctn
87-755	Carded	3/16, 7/32, 1/4, 5/16, 3/8	2 / 12



**3/8" DRIVE
5 PIECE SCREWDRIVER BIT CLIP RAIL SOCKET SET**

Product ID No.	Packed	Screwdriver Bit Sockets	Box/Ctn
87-754	Carded	1 Pt, 2 Pt, 3 Pt, Phillips* 1/4" and 9/32" Slotted	2 / 12

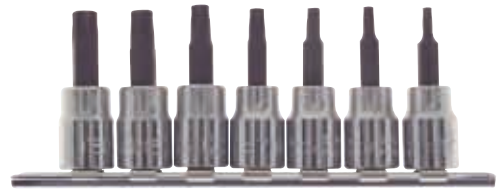

**3/8" DRIVE
7 PIECE TORX* BIT CLIP RAIL SOCKET SET**

Product ID No.	Packed	Torx Sockets	Box/Ctn
87-753	Carded	T-15, T-20, T-25, T-30, T-40, T-45, T-50	2 / 12



**1/2" DRIVE
10 PIECE STANDARD CLIP RAIL INCH SOCKET SET**

Product ID No.	Packed	Sockets 12 Points Deep	Box/Ctn
87-751	Carded	7/16, 1/2, 9/16, 5/8, 11/16, 3/4, 13/16, 7/8, 15/16, 1	2 / 12

Metric

Product ID No.	Packed	Sockets 12 Points Deep	Box/Ctn
87-752	Carded	10mm, 11mm, 12mm, 13mm, 14mm, 15mm, 16mm, 17mm, 18mm, 19mm	2 / 12

**1/4" DRIVE
13 PIECE SOCKET SET**

Ratchet, Spinner Handle,
3" Extension, 9 ea. 6 pt. Soc
metal tool box.



Product ID No.	6 Point Socket Sizes	Box/Ctn
86-600	3/16, 7/32, 1/4, 9/32, 5/16, 11/32, 3/8, 7/16, 1/2	1 / 6

**1/4" DRIVE
25 PIECE STANDARD
AND DEEP SOCKET SET**

Ratchet, Spinner Handle,
3" and 6" Extension Handle,
Universal Joint, 9 ea. 6 Pt.
Sockets, 3 ea. 8 Pt. Sockets,
7 ea. 6 Pt. Deep Sockets, metal
tool box.



Product ID No.	6 Point Socket Sizes	Box/Ctn
86-907	3/16, 7/32, 1/4, 9/32, 5/16, 11/32, 3/8, 7/16, 1/2 Sockets 6 Points Deep 1/4, 9/32, 5/16, 11/32, 3/8, 7/16, 1/2 Sockets 8 Points Deep 1/4, 5/16, 3/8	1 / 6

**3/8" DRIVE
20 PIECE SOCKET SET**

Ratchet, 3" and 6" Extensions, 5/8"
Spark Plug Socket, 9 ea. 6 Pt.
Sockets, 6 ea. 6 Pt. Deep Sockets,
Metal Tool Box.



Product ID No.	6 Point Socket Sizes	Box/Ctn
86-601	3/8, 7/16, 1/2, 9/16, 5/8, 11/16, 3/4, 13/16, 7/8 Sockets 6 Points Deep 3/8, 7/16, 1/2, 9/16, 11/16, 3/4	1 / 6

Metric

Ratchet, 3" and 6" Extensions, 5/8" Spark Plug Socket, 8 ea. 6 Pt.
Sockets, 6 ea. 7 Pt. Deep Sockets, Metal Tool Box.

Product ID No.	6 Point Socket Sizes	Box/Ctn
86-617	10mm, 12mm, 13mm, 14mm, 15mm, 17mm, 18mm 19mm Sockets 6 Points Deep 10mm, 12mm, 13mm, 14mm, 15mm, 17mm, 19mm	1 / 6

**3/8" DRIVE
12 PIECE SOCKET SET**

Ratchet, 3" Extension, 5/8" Spark
Plug Socket, 8 ea. 6 Pt. Sockets,
Metal Tool Box.



Product ID No.	6 Point Socket Sizes	Box/Ctn
86-918	5/16, 3/8, 7/16, 1/2, 9/16, 5/8, 11/16, 3/4	1 / 6

Metric

Product ID No.	6 Point Socket Sizes	Box/Ctn
86-615	10mm, 12mm, 13mm, 14mm, 15mm, 17mm, 18mm, 19mm	1 / 6

**3/8" DRIVE
16 PIECE SOCKET SET**

Ratchet, 3" Extension, 7 ea. 6 Pt. Inch Sockets,
7 ea. 6 Pt. Metric Sockets, clamshell with
formed insert tray.



Product ID No.	6 Point Socket Sizes	Box/Ctn
87-205	3/8, 7/16, 1/2, 9/16, 5/8, 11/16, 3/4, 10mm, 11mm, 12mm, 13mm, 14mm, 15mm, 17mm	0 / 4

**1/2" DRIVE
13 PIECE SOCKET SET**

Ratchet, 5" Extension, 5/8"
Spark Plug Socket, 9 ea.
12 pt. Sockets, Metal Tool Box.



Product ID No.	Sockets 12 Points	Box/Ctn
86-933	7/16, 1/2, 9/16, 5/8, 11/16, 3/4, 13/16, 7/8, 15/16	1 / 6

**1/2" DRIVE
18 PIECE SOCKET SET**

Ratchet, 17" Flex Handle,
5" Extension, Universal Joint,
13 ea. 12 Pt. Sockets, Metal Tool Box.



Product ID No.	Sockets 12 Points	Box/Ctn
86-936	7/16, 1/2, 9/16, 5/8, 11/16, 3/4, 13/16, 7/8, 15/16, 1, 1-1/16, 1-1/8, 1-1/4	1 / 6

**1/4" AND 3/8" DRIVE
21 PIECE SOCKET SET**

1/4" Drive: Spinner Handle, 6 ea. 1/4" 6 Pt. Sockets.
3/8" Drive: Ratchet, 3" and 6" Extensions, 5/8" Spark Plug Sockets, 3/8" F x 1/4" M Adapt 8 ea. 6 Pt. Sockets, Metal Tool Box.



Product ID No.	6 Point Socket Sizes	Box/Ctn
86-977	1/4" Drive: 3/16, 7/32, 1/4, 9/32, 5/16, 11/32 3/8" Drive: 3/8, 7/16, 1/2, 9/32, 5/8, 11/16, 3/4, 13/16	1 / 6

Metric

Product ID No.	6 Point Socket Sizes	Box/Ctn
86-619	1/4" Drive: 5mm, 6mm, 7mm, 8mm, 9mm, 10mm. 3/8" Drive: 12mm, 13mm, 14mm, 15mm, 16mm, 17mm, 18mm, 19mm	1 / 6

**1/4" AND 3/8" DRIVE 29 PI
SOCKET SET**

1/4" Drive: Spinner Handle, 5 ea. 6 Pt. Inch Sockets, 5 ea. 6 Pt. Metric Sockets
3/8" Drive: Ratchet, 3" and 6" Extensions, 5/8" Spark Plug Socket, 3/8" F x 1/4" M Adapter 6 ea. 6 Pt. inch Sockets, 6 ea. 6 Pt. Metric Sockets, Metal Tool Box.



Product ID No.	6 Point Socket Sizes	Box/Ctn
86-982	1/4" Drive: 1/4, 9/32, 5/16, 11/32, 3/8, 7mm, 8mm, 9mm, 10mm, 11mm 3/8" Drive: 7/16, 1/2, 9/16, 5/8, 11/16, 3/4, 12mm, 13mm, 14mm, 15mm, 17mm, 19mm	1 / 6

**1/4" AND 3/8" DRIVE
39 PIECE SOCKET SET**

1/4" Drive: Ratchet, 10 ea. 6 Pt. Inch Sockets, 10 ea. 6 Pt. Metric Sockets.
3/8" Drive: Ratchet, 3" Extension, 8 ea. 6 Pt. Inch Sockets, 8 ea. 6 Pt. Metric Sockets, Clamshell with Formed Insert Tray.



Product ID No.	6 Point Socket Sizes	Box/Ctn
87-207	1/4" Drive: 5/32, 3/16, 7/32, 1/4, 9/32, 5/16, 11/32, 3/8, 7/16, 1/2, 4mm, 5mm, 6mm, 7mm, 8mm, 9mm, 10mm, 11mm, 12mm, 13mm 3/8" Drive: 3/8, 7/16, 1/2, 9/16, 5/8, 11/16, 3/4, 13/16, 10mm, 11mm, 12mm, 13mm, 14mm, 15, 17mm, 19mm.	0 / 4

**1/4" AND 3/8" DRIVE
50 PIECE SOCKET SET**

1/4" Drive: Ratchet, Spinner Handle, 3" Extension, 10 ea. 6 Pt. Inch Sockets, 10 ea. 6 Pt. Metric Sockets
3/8" Drive: Ratchet, 3" Extension, 5/8" Spark Plug Socket, 8 ea. 6 pt. Inch Sockets, 9 ea. 6 pt. Inch metric sockets, 3 ea. 8 Pt. Inch Sockets, 4 ea. 6 Pt. Deep Sockets, Softside Zippered Carrying Case.



Product ID No.	6 Point Socket Sizes	Box/Ctn
87-195	1/4" Drive: 5/32, 3/16, 7/32, 1/4, 9/32, 5/16, 11/32, 3/8, 7/16, 1/2, 4mm, 5mm, 6mm, 7mm, 8mm, 9mm, 10mm, 11mm, 12mm, 13mm 3/8" Drive: 3/8, 7/16, 1/2, 9/16, 5/8, 11/16, 3/4, 13/16, 10mm, 11mm, 12mm, 13mm, 14mm, 15mm, 17mm, 18mm, 19mm Sockets 6 Points Deep 3/8" Drive: 3/8, 7/16, 1/2, 9/16, Sockets 8 Points Deep 3/8" Drive: 1/4, 5/16, 3/8	1 / 4

**1/4" AND 3/8" DRIVE
65 PIECE SOCKET SET**

1/4" Drive: Ratchet, 10 ea. 6 Pt. Inch Sockets, 9 ea. 12 Pt. Inch Sockets, 10 ea. 6 pt. Metric Sockets, 4 ea. 6 pt. Inch Deep Sockets.
3/8" Drive: Ratchet, 3" Extension, 5/8" Spark Plug Socket, 8 ea. 6 Pt. Inch Sockets, 7 ea. 12 Pt. Inch Sockets, 8 Ea. 6 Pt. Metric Sockets, 4 ea. 6 Pt. Inch Deep Sockets, Molded Case with Storage Compartment.



Product ID No.	6 Point Socket Sizes	Box/Ctn
87-208	1/4" Drive: 5/32, 3/16, 7/32, 1/4, 9/32, 5/16, 11/32, 3/8, 7/16, 1/2, 4mm, 5mm, 6mm, 7mm, 8mm, 9mm, 10mm, 11mm, 12mm, 13mm 3/8" Drive: 3/8, 7/16, 1/2, 9/16, 5/8, 11/16, 3/4, 13/16, 10mm, 11mm, 12mm, 13mm, 14mm, 15mm, 17mm, 19mm Sockets 6 Points Deep 1/4" Drive: 1/4, 9/32, 5/16, 11/32 3/8" Drive: 3/8, 7/16, 1/2, 9/16 Sockets 12 Points Deep 1/4" Drive: 3/16, 7/32, 1/4, 9/32, 5/16, 11/32, 3/8, 7/16, 1/2 3/8" Drive: 3/8, 7/16, 1/2, 9/16, 5/8, 11/16, 3/4	1 / 4

**3/4" DRIVE
21 PIECE SOCKET SET**

For use on heavy equipment and farm machinery. Full range of sizes and accessories. Chrome plated for rust resistant finish. Includes 20" Ratchet, 19" Flex Handle, 8" Extension, 12 Point Sockets, Metal Tool Box.



Product ID No.	12 Point Deep Sockets	Box/Ctn
87-557	7/8, 15/16, 1, 1-1/16, 1-1/8, 3-3/16, 1-1/4, 1-5/16, 1-3/8, 1-7/16, 1-1/2, 1-5/8, 1-11/16, 1-3/4, 1-13/16, 1-7/8, 2, 2-1/8, 2-3/16, 2-1/4, 2-3/8,	1 / 1

1/2" DRIVE IMPACT SOCKET 11 PIECE SET

For use on air or electric impact wrenches or ratchets. Thicker walls and special alloy steel for greater strength. Black finish for corrosion resistance. Standard length sockets in inch and metric.



Product ID No.	6 Point Socket Sizes	Box/Ctn
87-512	7/16, 1/2, 9/16, 5/8, 11/16, 3/4, 13/16, 7/8, 15/16, 1, 1-1/16	2 / 12
87-511	13mm, 14mm, 15mm, 16mm, 17mm, 18mm, 19mm, 21mm, 22mm, 24mm, 27mm	2 / 12

22 PIECE MECHANICS TOOL SET

1/4" Drive: 7ea. 6 Pt. Standard Sockets; 5 ea. 6 Pt. Metric Sockets.

3/8" Drive: 6 ea. 6 Pt. Standard Sockets, Ratchet, 3/8" to 1/4" Adapter.

Screwdrivers include: 4" Standard Slotted, #1 Phillips* Tip. Set is packed in a soft-sided zippered storage case.



Product ID No.	6 Point Socket Sizes	Box/Ctn
92-664	1/4" Drive: 5/32, 3/16, 7/32, 1/4, 9/32, 5/16, 11/32, 8mm, 9mm, 10mm, 11mm, 12mm 3/8" Drive: 3/8, 7/16, 1/2, 9/16, 5/8, 3/4	0 / 8

34 PIECE MECHANICS TOOL SET

1/4" Drive: 7 ea. 6 Pt. Standard Sockets, 6 ea. 6 Pt. Metric Sockets, 6" Spinner Handle.

3/8" Drive: 7 ea. 6 Pt. Standard Sockets, 6 ea. 6 Pt. Metric Sockets, Ratchet, 3" Extension Bar, 3/8" to 1/4" Adapter, 5/8" Spark Plug Sockets.

Screwdrivers include: 4" and 6" Slotted, #1 Phillips* Tip. Set is packed in a soft-sided zippered storage case.



Product ID No.	6 Point Socket Sizes	Box/Ctn
92-665	1/4" Drive: 5/32, 3/16, 7/32, 1/4, 9/32, 5/16, 11/32, 4mm, 5mm, 6mm, 7mm, 8mm, 9mm 3/4" Drive: 3/8, 7/16, 1/2, 9/16, 5/8, 11/16, 3/4, 10mm, 11mm, 12mm, 13mm, 14mm, 15mm	0 / 8

54 PIECE MECHANICS TOOL SET

1/4" Drive: 10 ea. 6 Pt. Standard Sockets, 9 ea. 6 Pt. Metric Sockets; 4 ea. 6 Pt. Deep Sockets, 6" Spinner Handle.

3/8" Drive: 7 ea. 6 Pt. Standard Sockets, 8 ea. 6 Pt. Metric Sockets, Ratchet, 3" Extension Bar, 3/8" to 1/4" Adapter, 5/8" Spark Plug Socket.

Screwdrivers includes: 4" and 6" Slotted, #1 and #2 Phillips* Tip, Plus 7 Standard Hex Keys. Set is packed in a soft-sided zippered storage case.



Product ID No.	6 Point Socket Sizes	Box/Ctn
92-666	1/4" Drive: 5/32, 3/16, 7/32, 1/4, 9/32, 5/16, 11/32, 3/8, 7/16, 1/2, 4mm, 5mm, 6mm, 7mm, 8mm, 9mm, 10mm, 11mm, 12mm 3/8" Drive: 3/8, 7/16, 1/2, 9/16, 5/8, 11/16, 3/4, 10mm, 11mm, 12mm, 13mm, 14mm, 15mm, 17mm, 18mm Sockets 6 Points Deep 1/4" Drive: 5/16, 11/32, 3/8, 7/16	0 / 6

*PHILLIPS registered trademark of Phillips Screw Co.

WRENCHES

Stanley wrenches are forged from high grade alloy. Precision trimming, broaching, grinding and polishing bring the wrench to exact specifications. Nickel chrome plating adds to the quality appearance and offers long lasting rust protection. Designed for strength and built for durability. Stanley offers consistent quality in a full complement of styles in inch and metric sizes.

OPEN END WRENCHES



Product ID No.	Opening in inches	Length in inches	Box/Ctn
86-800	1/4 x 5/16	4-1/2	3 / 24
86-801	3/8 x 7/16	5	3 / 24
86-803	1/2 x 9/16	6-3/8	3 / 24
86-806	9/16 x 5/8	7-1/16	3 / 24
86-808	11/16 x 3/4	8	3 / 24
86-809	13/16 x 7/8	8-15/16	3 / 24
86-811	15/16 x 1	10-1/16	3 / 24

Metric

Product ID No.	Opening in mm	Length in inches	Box/Ctn
86-817	6 x 7	4-11/16	3 / 24
86-818	8 x 9	4-3/4	3 / 24
86-821	10 x 11	5	3 / 24
86-823	12 x 13	5-11/16	3 / 24
86-824	14 x 15	6-3/16	3 / 24
86-827	16 x 17	6-13/16	3 / 24
86-828	18 x 19	8	3 / 24

COMBINATION WRENCHES



*6 Pt. Wrench All Others 12 pt.

Product ID No.	Opening in inches	Length in inches	Box/Ctn
86-831	1/4*	4	3 / 24
86-832	5/16*	4-1/2	3 / 24
86-833	3/8*	4-7/8	3 / 24
86-834	7/16*	5-7/16	3 / 24
86-835	1/2	6	3 / 24
86-836	9/16	6-3/4	3 / 24
86-837	5/8	7-1/2	3 / 24
86-838	11/16	8-1/4	3 / 24
86-839	3/4	9-1/4	3 / 24
86-840	13/16	10-1/4	3 / 24
86-841	7/8	11-1/4	3 / 24
86-842	15/16	12-7/16	3 / 24
86-843	1	13-1/2	2 / 12
86-844	1-1/16	14-7/8	2 / 12
86-845	1-1/8	16-1/4	2 / 12
86-846	1-1/4	17-11/16	2 / 12

Metric

Product ID No.	Opening in mm	Length in inches	Box/Ctn
86-852	7	4	3 / 24
86-853	8	4-1/2	3 / 24
86-854	9	4-11/16	3 / 24
86-855	10	4-7/8	3 / 24
86-856	11	5-7/16	3 / 24
86-857	12	5-3/4	3 / 24
86-858	13	6	3 / 24
86-859	14	6-3/4	3 / 24
86-860	15	7-1/8	3 / 24
86-861	16	7-1/2	3 / 24
86-862	17	7-15/16	3 / 24
86-863	18	8-3/8	3 / 24
86-864	19	9-1/4	3 / 24
86-866	21	10-1/4	3 / 24
86-867	22	11-1/4	3 / 24

BOX END WRENCHES



Product ID No.	Opening in mm	Length in inches	Box/Ctn
86-876	3/8 x 7/16	5/16	3 / 24
86-878	1/2 x 9/16	9-1/2	3 / 24
86-881	5/8 x 3/4	11-1/16	3 / 24
86-883	11/16 x 3/4	12	3 / 24
86-884	13/16 x 7/8	13	3 / 24
86-886	15/16 x 1	14-1/8	3 / 24

5 PIECE OPEN END WRENCH CLIP SET



Five individual open end wrenches, 1/4" x 3/4" capacities. Rust resistant polished chrome finish. Handy clip for easy carrying and storage.

Product ID No.	Size in inches	Box/Ctn
87-290	1/4" to 3/4"	0 / 4

5 PIECE COMBINATION WRENCH CLIP SET



Product ID No.	Size in inches	Box/Ctn
87-405	1/4" to 3/4"	0 / 4

6 PIECE COMBINATION WRENCH SET

Forged from alloy steel. Chrome plated to resist rust.



Product ID No.	Contents	Box/Ctn
87-959	3/8, 7/16, 1/2, 9/16, 5/8, 3/4	3 / 12
87-960	10mm, 11mm, 12mm, 13mm, 14mm, 15mm	3 / 12

9 PIECE COMBINATION WRENCH SET

Forged from alloy steel. Chrome plated to resist rust.



Product ID No.	Contents	Box/Ctn
87-961	1/4, 5/16, 3/8, 7/16, 1/2, 9/16, 5/8, 11/16, 3/4	3 / 12
87-962	7mm, 8mm, 9mm, 10mm, 12mm, 13mm, 15mm, 17mm, 19mm	3 / 12

5 PIECE OPEN END WRENCH SET

Forged from alloy steel. Chrome plated to resist rust.



Product ID No.	Contents	Box/Ctn
87-963	1/4 x 5/16, 3/8 x 7/16, 1/2 x 9/16, 9/16 x 5/8, 11/16 x 3/4	3 / 12
87-964	6mm x 7mm, 8mm x 9mm, 10mm x 11mm, 12mm x 13mm, 14mm x 15mm	3 / 12



14 PIECE COMBINATION WRENCH SET

Vinyl roll pouch.

Product ID No.	Opening in inches	Box/Ctn
86-970	3/8, 7/16, 1/2, 9/16, 5/8, 11/16, 3/4, 13/16, 7/8, 15/16, 1, 1-1/16, 1-1/8, 1-1/4	1 / 4

9 PIECE COMBINATION WRENCH SET

Vinyl roll pouch.

Product ID No.	Opening in inches	Box/Ctn
86-968	1/4, 5/16, 3/8, 7/16, 1/2, 9/16, 5/8, 11/16, 3/4	1 / 6

6 PIECE COMBINATION WRENCH SET

Professional set in vinyl roll pouch. Sizes range from 3/8" to 11/16"

Product ID No.	Opening in inches	Box/Ctn
86-967	3/8, 7/16, 1/2, 9/16, 5/8, 11/16 Wrenches 6 Each. Combination Wrenches	1 / 12



WARNING: WORK SAFELY WITH TOOLS
WEAR SAFETY GOGGLES.

MINIATURE LONG NOSE PLIER

Miniature long nose pliers feature high carbon steel construction, accurately aligned cutting edges hardened for durability and bonded vinyl grips for comfort.



Product ID No.	Length		Box/Ctn
	in	mm	
84-090	4	100	6 / 36

MINIATURE 4" DIAGONAL CUTTING PLIER

Miniature diagonal cutting pliers are designed for precise cutting. Precision machined cutting edges for use on most fine wire. Tempered steel with a rust resistant finish. Bonded vinyl grips for comfort.



Product ID No.	Length		Box/Ctn
	in	mm	
84-091	4	100	6 / 36

MINIATURE NEEDLE NOSE PLIER

Miniature needle nose pliers feature serrated 1-1/4" long jaws for use in tight places. Tempered jaws. Rust resistant finish and bonded vinyl grips.



Product ID No.	Length		Box/Ctn
	in	mm	
84-092	5	127	6 / 36

MINIATURE END NIPPER PLIER

Miniature end nippers are designed for fine wire cutting and hobby applications. Tempered steel for durability. Finely honed cutting edges. Bonded vinyl grips for comfort.



Product ID No.	Length		Box/Ctn
	in	mm	
84-093	4	102	6 / 36

MINIATURE BENT NOSE PLIER

Miniature bent nose pliers feature curved nose for applications where space is limited. Serrated jaws provide grip and leverage. Drop forged carbon steel for strength and durability. Bonded vinyl grips for comfort.



Product ID No.	Length		Box/Ctn
	in	mm	
84-094	5	127	6 / 36

SLIP JOINT PLIER

Drop-forged tempered steel. Rust resistant chrome finish.



Product ID No.	Length		Box/Ctn
	in	mm	
84-106	6	152	6 / 36
84-107	8	203	6 / 36

LONG NOSE PLIER

Strong tempered alloy steel pliers for wire loop forming and gripping fine work. Tapered jaws for working in tight places. Side cutting feature has finely honed edges. Cuts most types of wire. Precision balanced with bonded vinyl grips.



Product ID No.	Length		Box/Ctn
	in	mm	
84-120	5	127	6 / 36
84-121	6	152	6 / 36
84-123	7	60	6 / 36

DIAGONAL CUTTING PLIER

Drop forged tempered steel pliers have precision machined cutting edges for true cuts of most types of wire. Designed to provide maximum leverage and maintain sharpness. Rust resistant protective finish. Bonded vinyl grips.



Product ID No.	Length		Box/Ctn
	in	mm	
84-130	5	127	6 / 36
84-131	6	152	6 / 36
84-133	7	180	6 / 36

3 PIECE PLIER SET

Bonded vinyl grips for comfort.



Product ID No.	Contents	Box/Ctn
84-103	84-106 6" Slip Joint Plier 84-121 6" Long Nose Plier 84-131 6" Diagonal Plier	4 / 24

WARNING: Grips do not protect against electrical shock.



GROOVE JOINT PLIER

Strong, drop-forged tempered steel pliers hold and turn work of various sizes. Rust resistant polished chrome finish. Comfortable bonded vinyl grip.

Product ID No.	Length		Box/Ctn
	in	mm	
84-137	7	180	6 / 36
84-139	10	250	6 / 36
84-140	12	305	4 / 24



LINESMAN PLIER

Serrated jaw provide grip and leverage on heavy duty applications. Finely honed cutting edges cut most types of wire. Tempered alloy steel for strength and durability. Rust resistant protective finish. Comfortable bonded vinyl grip.

Product ID No.	Length		Box/Ctn
	in	mm	
84-150	7	180	6 / 36
84-151	8	203	6 / 36



FINE WOODWORKING CARPENTER'S NIPPERS

For removing and cutting nails. The beveled cutting edge are over 1" wide and machined to a smooth curved surface to protect your work surface when extracting a nail. Forged from high carbon steel, hardened and tempered for long life. The pivots and joints are precision machined for accuracy.

Product ID No.	Length		Box/Ctn
	in	mm	
84-185	9-3/4	245	6 / 30



PLIER

A handy tool that cuts electrical wire, strip insulation, shears screws and bolts clean, crimps terminals. Plus a plier for many more uses. All the action is up front, safely out of the way of hands and fingers. Pliers cut 4-40, 6-32, 8-32, 10-24 and 10-32 size threads.

Product ID No.	Overall Length		Box/Ctn
	in	mm	
84-203	8-1/2	215	6 / 36



WIRE STRIPPER

Cuts and strips wire from 10 to 26 gauge. Adjustable slide stop and hole for bending and looping wire. Rust resistant finish. Comfortable vinyl grips.

Product ID No.	Box/Ctn
84-213	5 / 50



2 PIECE PLIER AND WRENCH SET

Set includes 6" slip joint plier and 8" adjustable wrench. Quality tools for the most common fastening and holding jobs around home, shop and garage.

Product ID No.	Contents	Box/Ctn
90-474	84-106 6" Slip Joint Plier 84-368 8" Adjustable Wrench	4 / 24



THE "CLAW" ADJUSTABLE WRENCH

■ Grips fastener on four sides — won't slip off. Moveable jaw has precision adjustment and won't slip like conventional adjustable wrenches. Handle is investment cast for strength. Packaged in a blister card.

Product ID No.	Length		Box/Ctn
	in	mm	
87-454	6	150	6 / 36
87-455	8	200	6 / 36
87-458	10	250	6 / 24



ADJUSTABLE WRENCH

Strong tempered steel chrome vanadium steel wrench for fastening or holding nuts and bolts in shop or home. Precision machined screw for smooth jaw adjustment. Rust resistant polished chrome finish. Handy hang hole for wall storage.

Product ID No.	Length		Box/Ctn
	in	mm	
87-366	6	152	6 / 36
87-368	8	203	6 / 36
87-470	10	250	6 / 36
87-472	12	305	4 / 24

WARNING: Grips do not protect against electrical shock.



PIPE WRENCH

Drop forged alloy steel jaws. Precision milled teeth. Four sizes for light, medium and heavy duty applications.

Product ID No.	Length		Box/Ctn
	in	mm	
87-476	8	203	6 / 36
87-477	10	250	4 / 24
87-478	14	355	2 / 12
87-479	18	455	2 / 6



CARPENTER'S PENCILS

Handy pencils for marking wood and drywall with measurement notations. preferred by pros and DIY'ers alike.

Product ID No.	Box/Ctn
93-930	10 / 60

WEB CLAMP

Tough, heavy duty 12 ft. (365 cm) long nylon webbing holds all sizes and irregular shapes under positive, even pressure. Clamp tightens easily with wrench or screwdriver. Ratchet action keeps webbing tight.



Product ID No.	Box/Ctn
83-159	6 / 6



SPRING CLAMP

Heavy gauge steel with vinyl grips and tips to prevent marring work. Jaws specially formed to hold flat or round objects.

Product ID No.	Length		Jaw Opening		Box/Ctn
	in	mm	in	mm	
83-261	4-1/16	102	7/8	22	12 / 36
83-262	6-1/8	153	1-3/4	45	12 / 36
83-263	8-5/8	220	2-3/4	70	6 / 36

SAW HORSE BRACKETS

For use with standard 2" x 4" lumber. Holes for screws or nail provide for permanent construction.



Product ID No.	Box/Ctn
83-362	1 / 12



PANEL CARRY

14" handle for extra reach. Better balance and control. Better visibility while carrying. Angled handle keeps hands away from panel for comfort.



Product ID No.	Box/Ctn
93-300 High Visibility Orange	6 / 6
93-301 High Visibility Yellow	6 / 6

WARNING: Grips do not protect against electrical shock.



Tools Sold Separately

CONTRACTOR GRADE™ CARPENTER'S TOOL POUCH SET

5" padded belt provides comfort and support. Super tough Anso-tex* Nylon provides superior puncture and wear resistance. Heavy duty, quick-release nylon buckle. Innovative hook and loop system designed to hold pouches securely in place. Large, extra deep pockets provide convenient storage for tools, nails and other equipment. Tape pouch holds 16"-30" tapes. Available in sizes small and medium.

Product ID No.	Size	Box/Ctn
70-206 Carpenter's Set Small	29" — 34" Waist	1 / 6
70-207 Carpenter's Set Medium	35" — 39" Waist	1 / 6



CONTRACTOR GRADE™ 5" PADDED TOOL BELT

Fits all Stanley nail bags and tool pouches. Thick padding provides comfort and support. Super tough Anso-tex* nylon provides superior puncture and wear resistance. Heavy duty, quick-release nylon buckle. Innovative hook and loop system designed to hold pouches securely in place. Available in sizes small, medium and large.

Product ID No.	Size	Box/Ctn
70-100 5" Padded Belt Small	29" — 34" Waist	1 / 6
70-101 5" Padded Belt Medium	35" — 39" Waist	1 / 6
70-102 5" Padded Belt Large	39" — 43" Waist	1 / 6

CONTRACTOR GRADE™ FRAMER'S POUCH WITH TOOL HOLDERS

Designed to fit Stanley 5" padded belt. Super tough Anso-tex* nylon provides superior puncture and wear resistance. Large pocket sizes, coupled with storage for chisels, make this pouch ideal for the professional framer. Additional small pockets for pencils, knives, etc. Available in either right or left design. Cradle design, steel hammer loop for added stability.



Product ID No.	Pocket Size	Box/Ctn
70-307 Framer's pouch w/Tool Holders (Right)	8" (w) x 4-3/4" (d) 7-1/2" (w) x 4-5/8" (d)	1 / 6

CONTRACTOR GRADE™ CORDLESS DRILL HOLDER

Super tough Anso-tex* nylon provides superior puncture and wear resistance. Designed to fit Stanley 5" padded belt. Holds most brands of drills. Designed for comfort and balanced carrying. Features a safety strap fastener and a place to store 3 extra drill bits.



Product ID No.	Overall Size	Box/Ctn
70-400 Cordless Drill Holder	15"(h) x 5" (w)	1 / 6

Tools Sold Separately

*Anso-tex is a registered trademark of Allied Signal.

PROD. ID. DESCRIPTION	PAGE NO.	PROD. ID. DESCRIPTION	PAGE NO.
01-710 Expansive Bit	.6	10-127B Contractor Grade™ Super Heavy Duty Slimknife® Trimming Knife	.15
01-711 Expansive Bit	.6	10-139 High Visibility Mitey-Knife® Pocket Knife	.15
02-660 Bit Brace	.6	10-150 Quick Point™ Knife 9 mm	.14
03-043 Fine Woodworking Push Drill	.6	10-151 Quick Point™ Knife 18 mm	.14
03-046 Yankee® Push Drill	.6	10-165 High Visibility Plastic Retractable Utility Knife	.12
03-049 Yankee® Economy Push Drill	.6	10-175 Homeowner's Retractable Utility Knife	.11
03-103 Hand Drill	.6	10-176 High Visibility Homeowner's Utility Knife	.11
03-105 Hand Drill	.6	10-177 High Visibility Homeowner's Utility Knife	.11
04-059 Doweling Jig	.7	10-179 High Visibility Interlock® Retractable Utility Knife	.11
04-069 8 Piece Drill Point Sets For Yankee® Push Drill	.6	10-189 Interlock® Self-Retracting Utility Knife	.11
04-070 4 Piece Drill Point Sets For Yankee® Push Drill	.6	10-189C Interlock® Self-Retracting Utility Knife	.11
04-137 Countersink/Wood	.7	10-190 Leather Utility Knife Holster	.13
04-140 Countersink/Wood and Metal	.7	10-209 Contractor Grade™ 199® Fixed Blade Utility Knife	.12
04-142 Countersink/Wood and Metal	.7	10-218 Contractor Grade™ Super Heavy Duty 18mm Snap-Off Blade Knife	.14
04-144 Countersink/Wood and Metal	.7	10-218B Contractor Grade™ Super Heavy Duty 18mm Snap-Off Blade Knife	.14
04-418 Circle Cutter	.7	10-239 Metal Mitey-Knife® Pocket Knife	.15
04-419 Circle Cutter	.7	10-280 Standard Snap-Off Blade	.15
04-621 Screw-Mate® Adjustable Drill and Countersink	.7	10-299 299® Fixed Blade Interlock® Utility Knife	.13
04-622 Screw-Mate® Adjustable Drill and Countersink	.7	10-380 Self-Locking Snap-Off Cartridge Knife	.14
04-623 Screw-Mate® Adjustable Drill and Countersink	.7	10-399 Fixed Blade Swivel-Lock® Knife	.13
04-624 Screw-Mate® Adjustable Drill and Countersink	.7	10-401 Hobby Knife	.15
04-702 Screw Sink™ Counterbores	.7	10-402 Hobby Knife	.15
04-703 Screw Sink™ Counterbores	.7	10-480 Contractor Grade™ DynaGrip™ Snap-Off Cartridge Knife	.14
04-704 Screw Sink™ Counterbores	.7	10-499 Quick Change Retractable Utility Knife	.11
04-705 Screw Sink™ Counterbores	.7	10-509 Linoleum Flooring Knife	.13
04-706 Screw Sink™ Counterbores	.7	10-519 Fixed Blade Scoring Knife	.13
04-707 Screw Sink™ Counterbores	.7	10-520 Swivel-Lock® Carpet Knife	.12
04-708 Screw Sink™ Counterbores	.7	10-525 Contractor Grade™ Retractable Carpet Knife	.10
04-709 Screw Sink™ Counterbores	.7	10-550 Contractor Grade™ Super Heavy Duty Fixed Blade Utility Knife	.12
04-711 Screw Sink™ Counterbores	.7	10-550B Contractor Grade™ Super Heavy Duty Fixed Blade Utility Knife	.12
04-715 5 Piece Screw Sink™ Set	.7	10-779 Contractor Grade™ DynaGrip™ Retractable Utility Knife	.10
04-721 Plug Cutters	.7	10-989 Contractor Grade™ Swivel-Lock® Retractable Utility Knife	.10
04-722 Plug Cutters	.7	11-031 Mitey-Knife® Blade	.18
04-723 Plug Cutters	.7	11-040 Sheepfoot Replacement Blade For Pocket Knife 10-049	.18
04-724 Plug Cutters	.7	11-041 Utility Blade For Pocket Knife 10-049	.18
04-725 Fractional Size, Plug Cutters	.7	11-111 Whittling Craft Blade	.18
04-726 Fractional Size, Plug Cutters	.7	11-114 Curved Craft Blade	.18
04-727 Fractional Size, Plug Cutters	.7	11-300 9mm Quick-Point™ Blade	.18
10-039 Mitey-Knife® Key Chain Pocket Knife	.15	11-301 18mm Quick-Point™ Blade	.18
10-049 Pocket Knife	.15	11-411 No. 11 Hobby Knife Blade	.18
10-065 Plastic Retractable Utility Knife	.12	11-516 Single Edge Razor Blade	.17, 41
10-079 Interlock® Retractable Utility Knife	.10		
10-099 99® Retractable Utility Knife	.10		
10-109 Slimknife® Multi Purpose Knife	.15		
10-113 Insulation Cutter	.12		
10-122 Contractor Grade™ Super Heavy Duty Retractable Knife With Holster	.10		
10-122B Contractor Grade™ Super Heavy Duty Retractable Knife With Holster	.10		
10-127 Contractor Grade™ Super Heavy Duty Slimknife® Trimming Knife	.15		

PROD. ID.	DESCRIPTION	PAGE NO.	PROD. ID.	DESCRIPTION	PAGE NO.
11-525	Carpet Knife Blade	18	14-050	Fine Woodworking Honing Guide	22
11-530	Heavy Duty Carpet Knife Blade	18	14-120	Glass Cutter	24
11-911	1991® Regular Duty Utility Blade	17	14-501	Offset Aviations Snip	23
11-911A	1991® Regular Duty Utility Blade	17	14-502	Offset Aviations Snip	23
11-921	1992® Heavy Duty Utility Blade	17	14-542	Aviation Snips	23
11-921A	1992® Heavy Duty Utility Blade	17	14-543	Aviation Snips	23
11-921C	1992® Contractor Grade Heavy Duty Utility Blade	17	14-544	Aviation Snips	23
11-921L	1992® Heavy Duty Utility Blade	17	14-548	All Purpose Snips Straight Pattern	23
11-921T	1992® Heavy Duty Utility Blade 10-Pack Dispenser	17	14-549	All Purpose Snips Straight Pattern	23
11-931	Extra Heavy Duty Utility Blade	17	14-550	All Purpose Snips Straight Pattern	23
11-931A	Extra Heavy Duty Utility Blade	17	14-755	Contractor Grade™ Aviation Snip	23
11-931C	Extra Heavy Duty Utility Blade	17	14-756	Contractor Grade™ Aviation Snip	23
11-931D	Contractor Grade™ Extra Heavy Duty Utility Blade	17	14-757	Contractor Grade™ Aviation Snip	23
11-941	Utility Scoring Blade	18	14-758	Contractor Grade™ Offset Aviation Snip	23
11-942	Scoring Knife Blade	17	15-022	Contractor Grade™ Dovetail Saw	31
11-961	1996™ Hook Blade	17	15-025	Contractor Grade™ Short Cut® Drywall Saw	27
11-961A	1996™ Hook Blade	17	15-039	Scroll Saw Blade	34
11-980	Linoleum Blade	18	15-057	Coping Saw Blade	28
11-983	Large Hook Blade	17	15-058	Coping Saw Blade	28
11-983A	Large Hook Blade	17	15-059	Coping Saw Blade	28
11-984	Large Hook Blade	17	15-060	Coping Saw Blade	28
11-987	Round Point Utility Blade	17	15-061	Coping Saw Blade	28
11-988	Round Point Utility Blade	17	15-085	Contractor Grade™ Short Cut® Tool Box Saw	25
12-007	Fine Woodworking Bailey® Jointer or Try Plane	20	15-086	Contractor Grade™ Short Cut® Tool Box Saw	25
12-014	Fine Woodworking Bailey® Corrugated Base Plane	20	15-087	Contractor Grade™ Short Cut® Saw	25
12-015	Fine Woodworking Bailey® Corrugated Base Plane	20	15-088	Contractor Grade™ Short Cut® Saw	25
12-016	Fine Woodworking Bailey® Corrugated Base Plane	20	15-090	Nest-of-Saws	31
12-080	Fine Woodworking Cabinet Scraper	22	15-092	Nest-of-Saw Replacement Blade	31
12-101	Small Trimming Plane	21	15-097	Coping Saw Blade	28
12-116	110® Block Plane	20	15-100	Contractor Grade™ Compass Saw	28
12-203	Smooth Plane	20	15-101	Contractor Grade™ Compass Saw	28
12-204	Smooth Plane	20	15-104	Coping Saw	28
12-204N	Smooth Plane	20	15-104A	Coping Saw with Extra Blades	28
12-205	Jack Plane	21	15-106	Coping Saw	28
12-220	Block Plane	20	15-106A	Coping Saw with Extra Blades	28
12-220N	Block Plane	20	15-110	Pro Handsaw	26
12-247	Adjustable Block Plane	20	15-113	Contractor Grade™ High Tension Hacksaw	33
12-252	Block Plane Adjustable Cutter	21	15-114	Wood Handle Compass Saw	28
12-253	Block Plane Manual Adjustable Cutter	21	15-118	Pro Handsaw	26
12-331	Replacement Cutter For Iron Plane	22	15-119	Pro Handsaw	26
12-338	Replacement Cutter For Iron Plane	22	15-120	High Tension Hacksaw	33
12-404	Adjustable Bench Plane	20	15-175	Pistol Grip Keyhole Saw	29
12-504	Fine Woodworking Block Plane Irons	22	15-206	Wallboard Saw	29
12-904	Contractor Grade™ Smooth Bottom Bench Plane	20	15-207	Drywall Saw	27
12-905	Contractor Grade™ Smooth Bottom Jack Plane	21	15-210	Mini-Hack™ Saw	32
12-906	Contractor Grade™ Smooth Bottom Jack Plane	21	15-212	Wood Handle Compass Saw	28
12-920	Contractor Grade™ Block Plane	20	15-218	Fine Woodworking Junior Quick Release Hacksaw	33
12-951	Contractor Grade™ Spoke Shave	21	15-252	Fine Woodworking Back / Dovetail Saw with Reversible Handle	31
12-960	Contractor Grade™ Low Angle Plane	21	15-265	Rubber Grip Hacksaw	33
12-975	Contractor Grade™ Adjustable Bullnose Rabbet Plane	21	15-275	Keyhole Saw	29
12-978	Contractor Grade™ Bullnose Rabbet Plane	21			

PROD. ID. DESCRIPTION	PAGE NO.	PROD. ID. DESCRIPTION	PAGE NO.
15-276 Extra Blades For Keyhole Saw 15-275	.29	15-672 Contractor Grade™ Short Cut® Back Saw	.30
15-277 Extra Blades For Keyhole Saw 15-275	.29	15-673 Contractor Grade™ Short Cut® Back Saw	.30
15-285 Fixed Frame Hacksaw	.33	15-726 726 Handsaw	.27
15-300 Crosscut Handsaw	.27	15-739 Dovetail Saw	.31
15-333 Folding Pocket Saw	.30	15-744 Aggressive Tooth Replacement Blade	.30
15-334 Short Cut® Tool Box Saw	.25	15-764 Economy Wallboard Saw	.29
15-335 Short Cut® Handsaw	.26	15-774 Hole Saw Starter Kit	.35
15-336 Short Cut® Handsaw	.26	15-775 General Purpose Panel Saw	.27
15-350 Hard Tooth™ Handsaw	.26	15-777 Traditional Saw	.27
15-351 Hard Tooth™ Compass Saw	.28	15-779 Heavy Duty Mandrel	.34
15-352 Hard Tooth™ Back Saw	.30	15-800 Short Cut® Pruner Saw	.31
15-355 Hard Tooth™ Handsaw	.26	15-802 Hacksaw Blades 15-800 Series	.34
15-372 California Curved Pruning Saw	.31	15-802A Hacksaw Blades 15-800 Series	.34
15-374 Straight Double Edge Pruning Saw	.31	15-804 Hacksaw Blades 15-800 Series	.34
15-408 Tubular Frame Hacksaw	.33	15-804A Hacksaw Blades 15-800 Series	.34
15-410 Carbide Grit Blades, Hacksaw Blade	.34	15-808 Hacksaw Blades 15-800 Series	.34
15-412 Carbide Grit Blades, Hacksaw Blade	.34	15-808A Hacksaw Blades 15-800 Series	.34
15-422 Hole Saw 15-400 Series	.35	15-809 Contractor Grade™ Metal Mini-Hack™ Utility Saw	.32
15-427 Carbide Grit Sabre/Jig Saw Blade	.34	15-822 Hacksaw Blades 15-800 Series	.34
15-428 Carbide Grit Sabre/Jig Saw Blade	.34	15-822A Hacksaw Blades 15-800 Series	.34
15-443 Compass Saw	.28	15-824 Hacksaw Blades 15-800 Series	.34
15-446 Bow Saw Blade	.32	15-824A Hacksaw Blades 15-800 Series	.34
15-448 Bow Saw Blade	.32	15-828 Hacksaw Blades 15-800 Series	.34
15-449 Bow Saw	.32	15-828A Hacksaw Blades 15-800 Series	.34
15-451 Bow Saw	.32	15-902 Hacksaw Blades 15-900 Series	.34
15-453 Bow Saw	.32	15-902A Hacksaw Blades 15-900 Series	.34
15-459 Back Saw	.30	15-904 Hacksaw Blades 15-900 Series	.34
15-509 Back Saw	.30	15-904A Hacksaw Blades 15-900 Series	.34
15-520 Handsaw	.26	15-905 Fine Woodworking Quick Release Junior Hacksaw Blade	.33
15-526 Handsaw	.26	15-908 Hacksaw Blades 15-900 Series	.34
15-528 Handsaw	.26	15-908A Hacksaw Blades 15-900 Series	.34
15-534 Short Cut® Tool Box Saw	.25	15-922 Hacksaw Blades 15-900 Series	.34
15-535 Short Cut® Handsaw	.26	15-922A Hacksaw Blades 15-900 Series	.34
15-536 Short Cut® Handsaw	.26	15-924 Hacksaw Blades 15-900 Series	.34
15-556 Contractor Grade™ Cushion Grip Wallboard Saw	.29	15-924A Hacksaw Blades 15-900 Series	.34
15-565 Adjustable Hacksaw	.33	15-926 Hacksaw Blades 15-900 Series	.34
15-579 Aggressive Tooth Fast Cutting Saw	.26	15-928 Hacksaw Blades 15-900 Series	.34
15-580 Aggressive Tooth Fast Cutting Saw	.26	15-928A Hacksaw Blades 15-900 Series	.34
15-613 Bi-Metal Hacksaw Blade 15-600 Series	.34	15-939 Hacksaw Blades 15-900 Series	.34
15-627 Bi-Metal Hacksaw Blade 15-600 Series	.34	15-955 Hacksaw Blades 15-900 Series	.34
15-628 Bi-Metal Hacksaw Blade 15-600 Series	.34	16-150 3 Piece Wood Chisel Set	.73
15-629 Bi-Metal Hacksaw Blade 15-600 Series	.34	16-180 3 Piece Wood Chisel Set	.73
15-630 Bi-Metal Hacksaw Blade 15-600 Series	.34	16-200A 4 Piece Wood Chisel Set	.73
15-631 Bi-Metal Hacksaw Blade 15-600 Series	.34	16-204 Wood Chisel	.73
15-632 Bi-Metal Hacksaw Blade 15-600 Series	.34	16-208 Wood Chisel	.73
15-634 Wood Handle Compass Saw	.28	16-212 Wood Chisel	.73
15-635 Back/Mitre Saw	.30	16-216 Wood Chisel	.73
15-636 Back/Mitre Saw	.30	16-220 Wood Chisel	.73
15-637 Back/Mitre Saw	.30	16-224 Wood Chisel	.73
15-640 Saw Set	.34		
15-666 Aggressive Tooth Folding Pocket Saw	.30		

PROD. ID.	DESCRIPTION	PAGE NO.	PROD. ID.	DESCRIPTION	PAGE NO.
16-900	3 Piece Wood Chisel Set	72	20-230	Short Cut® Pruning Saw	31
16-901	6 Piece Wood Chisel Set	72	20-330	Molded Saw Protector	26
16-902	9 Piece Wood Chisel Set	72	20-331	Contractor Grade™ Flush Cut Saw	30
16-903	Wood Chisel	72	20-334	Saw Protector with Short Cut® Saw (15-334)	26
16-904	Wood Chisel	72	20-437	Bow Saw Blade	32
16-905	Wood Chisel	72	20-447	Bow Saw/Hacksaw	32
16-906	Wood Chisel	72	20-600	Clamping Mitre Box With Saw	35
16-907	Wood Chisel	72	21-115	Surform® Shaver	38
16-908	Wood Chisel	72	21-291	Surform® Round Replacement Blade	39
16-909	Wood Chisel	72	21-293	Surform® Standard Cut Blade Replacement Blade	39
16-910	Wood Chisel	72	21-295	Surform® Flat File	38
16-911	Wood Chisel	72	21-296	Surform® Plane	38
16-947	Fine Woodworking Wood Gouge	73	21-297	Surform® Round File	38
16-952	Fine Woodworking Wood Gouge	73	21-299	Surform® Half Round Replacement Blade	39
18-460	3 Piece Cold Chisel Set	74	21-393	Surform® Fine Cut Replacement Blade	39
18-509	Electrician Flooring Chisel	74	21-398	Surform® Fine Cut Replacement Blade	39
18-511	Electrician Flooring Chisel	74	21-399	Surform® Pocket Plane	38
18-536	Brick Set	74	21-515	Surform® Shaver Replacement Blade	39
18-606C	Cold Chisel	74	22-004	4 Piece File Set	40
18-608C	Cold Chisel	74	22-006	Mill Bastard File	40
18-610C	Cold Chisel	74	22-008	Mill Bastard File	40
18-612C	Cold Chisel	74	22-010	Mill Bastard File	40
18-615C	Cold Chisel	74	22-038	Half Round Bastard File	40
18-621C	Cold Chisel	74	22-100	4-Way™ Rasp	40
18-622C	Cold Chisel	74	22-434	Short Cut® Saw Sharpening Kit	40
18-628C	Pin Punch	74	28-035	Refinishing Hand Scraper	41
18-630C	Pin Punch	74	28-100	High Visibility Mini Blade Scaper	41
18-631C	Pin Punch	74	28-139	Scraper	40
18-650C	Starting Solid Punch	74	28-140	Putty Knife	40
18-661C	Prick Punch	74	28-141	Putty Knife	40
18-665C	Center Punch	74	28-142	Putty Knife	40
18-677C	Drift Aligning Punch	74	28-170	Burn-Off Scraper	41
19-035	Workmaster® Mitre Box With Saw	35	28-189	Scraper	41
19-112	Plastic Mitre Box	35	28-240	Putty Knife	40
19-114	All Metal Mitre Box Saw	35	28-241	Putty Knife	40
19-600	Plastic Mitre Box	35	28-242	Putty Knife	40
19-614	All Metal Mitre Box Saw	35	28-244	Joint Knife	40
20-001	High Tension-Low Profile Hacksaw	33	28-246	Joint Knife	40
20-003	Coping Saw Blade	28	28-290	2-Edge Scraper Replacement Blade	41
20-065	Contractor Grade™ Short Cut® Saw	25	28-292	2-Edge Scraper Replacement Blade	41
20-100	Culinary Saw	32	28-500	Retractable Razor Blade Scraper	41
20-101	Culinary Saw Blade	32	28-510	Single Edge Razor Blades	17, 41
20-112	Clamping Mitre Box	35	28-538	Wood Handle Joint Knife	40
20-115	Contractor Grade™ High Tension Hacksaw	33	28-539	Wood Handle Scraper	40
20-219	Multi Saw	30	28-540	Wood Handle Putty Knife	40
20-220	Contractor Grade™ Cushion Grip Multi Saw	30	28-541	Wood Handle Putty Knife	40
20-221	Contractor Grade™ Mini Utility Short Cut® Saw	27	28-542	Wood Handle Putty Knife	40
20-222	Contractor Grade™ Jet Cut® Tool Box Saw	25	28-543	Wood Handle Scraper	40
20-223	Contractor Grade™ Cushion Grip Short Cut® Tool Box Saw	25	28-546	Wood Handle Joint Knife	40
			28-593	Window Scraper	41
			28-596	Glass and Tile Scraper	41

PROD. ID.	DESCRIPTION	PAGE NO.	PROD. ID.	DESCRIPTION	PAGE NO.
28-597	4" Scraper Blade41	30-951	High Visibility Green Leverlock® Tape Rule47
28-612	4-Edge Paint Scraper41	30-957	High Visibility Green Leverlock® Tape Rule47
28-616	2-Edge Paint Scraper41	30-958	High Visibility Green Leverlock® Tape Rule47
28-617	2-Edge Paint Scraper41	30-982	High Visibility Green Leverlock® Tape Rule47
28-619	2-Edge Paint Scraper41	30-984	High Visibility Green Leverlock® Tape Rule47
28-631	2-Edge Scraper Replacement Blade41	30-985	High Visibility Red Leverlock® Tape Rule47
28-634	4-Edge Scraper Replacement Blade41	30-986	High Visibility Green Leverlock® Tape Rule47
28-703	Polypropylene Handle Scraper40	30-995	High Visibility Red Leverlock® Tape Rule47
28-713	Polypropylene Handle Scraper40	30-997	High Visibility Green Leverlock® Tape Rule47
30-038	Pocket Tape Rule47	33-076	Powerlock® Tape Rule45
30-039	Pocket Tape Rule47	33-113	Powerlock® Pocket Tape Rule46
30-040	Pocket Tape Rule47	33-115	Powerlock® Pocket Tape Rule46
30-074	High Visibility Orange Leverlock® Tape Rule47	33-116	Powerlock® Tape Rule45
30-076	High Visibility Orange Leverlock® Tape Rule47	33-117	Contractor Grade™ Heavy Duty Powerlock® Tape Rule44
30-333	High Visibility Red Leverlock® Tape Rule47	33-158	Powerlock® Tape Rule45
30-434	High Visibility Green Leverlock® Key Tape47	33-166	Powerlock® Tape Rule45
30-454	Fractional Read Tape Rule47	33-180	Powerlock® Tape Rule46
30-455	Stanley® Tape Rule47	33-194	Powerlock® Tape Rule45
30-456	Stanley® Tape Rule47	33-195	Powerlock® Tape Rule45
30-457	Stanley® Tape Rule47	33-198	Powerlock® Tape Rule45
30-458	Stanley® Tape Rule47	33-203	Powerlock® Tape Rule46
30-459	Stanley® Tape Rule47	33-208	Powerlock® Tape Rule46
30-485	Stanley® Tape Rule47	33-210	Powerlock® Tape Rule46
30-486	Stanley® Tape Rule47	33-212	Powerlock® Tape Rule46
30-487	Stanley® Tape Rule47	33-215	Powerlock® Tape Rule46
30-488	Stanley® Tape Rule47	33-223	Powerlock® Tape Rule46
30-491	High Visibility Orange Leverlock® Tape Rule47	33-224	Contractor Grade™ MaxSteel™ Tape Rule44
30-494	High Visibility Orange Leverlock® Tape Rule47	33-225	Contractor Grade™ MaxSteel™ Tape Rule44
30-495	Stanley® Tape Rule47	33-235	Powerlock® Tape Rule45
30-496	Stanley® Tape Rule47	33-238	Powerlock® Tape Rule46
30-497	Stanley® Tape Rule47	33-259	Powerlock® Tape Rule45
30-506	Pocket Tape Rule47	33-272	Contractor Grade™ Heavy Duty Powerlock® Tape Rule44
30-508	Leverlock® Tape Rule46	33-310	Powerlock® Tape Rule45
30-509	Leverlock® Tape Rule46	33-312	Powerlock® Tape Rule45
30-511	Leverlock® Tape Rule46	33-316	Contractor Grade™ Heavy Duty Powerlock® Tape Rule44
30-512	Leverlock® Tape Rule46	33-320	Powerlock® Tape Rule45
30-513	Leverlock® Tape Rule46	33-328	Powerlock® Tape Rule45
30-516	Leverlock® Tape Rule46	33-354	Contractor Grade™ Heavy Duty Powerlock® Tape Rule44
30-525	Leverlock® Tape Rule46	33-355	Contractor Grade™ Heavy Duty Powerlock® Tape Rule44
30-534	Leverlock® Tape Rule46	33-416	Contractor Grade™ Heavy Duty Powerlock® Tape Rule44
30-537	Leverlock® Tape Rule46	33-423	Powerlock® Tape Rule45
30-562	Leverlock® Tape Rule46	33-425	Powerlock® Tape Rule45
30-563	Leverlock® Tape Rule46	33-427	Powerlock® Tape Rule45
30-564	Leverlock® Tape Rule46	33-428	Powerlock® Tape Rule45
30-575	High Visibility Orange Leverlock® Tape Rule47	33-429	Powerlock® Tape Rule45
30-625	Leverlock® Tape Rule46	33-430	Powerlock® Tape Rule45
30-913	High Visibility Green Leverlock® Tape Rule47	33-432	Powerlock® Tape Rule45
30-914	High Visibility Green Leverlock® Tape Rule47	33-433	Powerlock® Tape Rule45
30-915	High Visibility Green Leverlock® Tape Rule47	33-442	Powerlock® Tape Rule45
30-925	High Visibility Green Leverlock® Tape Rule47	33-443	Powerlock® Tape Rule45
30-927	High Visibility Orange Leverlock® Tape Rule47	33-445	Contractor Grade™ Heavy Duty Powerlock® Tape Rule44

PROD. ID.	DESCRIPTION	PAGE NO.	PROD. ID.	DESCRIPTION	PAGE NO.
33-446	Contractor Grade™ Heavy Duty Powerlock® Tape Rule	.44	39-130	Powerlock® Key Tape	.46
33-447	Contractor Grade™ Heavy Duty Powerlock® Tape Rule	.44	39-133	Powerlock® Key Tape	.46
33-512	Contractor Grade™ Heavy Duty Powerlock® Tape Rule	.44	42-018	Silver I-Beam Level	.57
33-525	Contractor Grade™ Heavy Duty Powerlock® Tape Rule	.44	42-025	Contractor Grade™ Level Case	.57
33-570	Mason's Modular Spacing Powerlock® Tape Rule	.45	42-027	Contractor Grade™ Level Case	.57
33-575	Mason's Brick Spacing Powerlock® Tape Rule	.45	42-125	Contractor Grade™ Heavy Duty Double Vial I-Beam Level	.56
33-587	Contractor Grade™ Heavy Duty Power Stop® Tape Rule	.45	42-150	Contractor Grade™ Heavy Duty Double Vial I-Beam Level	.56
33-589	Contractor Grade™ MaxSteel™ Tape Rule	.44	42-173	Contractor Grade™ Heavy Duty Double Vial I-Beam Level	.56
33-590	Contractor Grade™ MaxSteel™ Tape Rule	.44	42-179	Contractor Grade™ Heavy Duty Double Vial I-Beam Level	.56
33-591	Contractor Grade™ MaxSteel™ Tape Rule	.44	42-180	Contractor Grade™ Top Read I-Beam Magnetic Level	.57
33-599	Contractor Grade™ MaxSteel™ Tape Rule	.44	42-182	Utility Level	.58
33-600	Contractor Grade™ MaxSteel™ Tape Rule	.44	42-184	High Visibility Plastic Line Level	.58
33-603	Contractor Grade™ MaxSteel™ Tape Rule	.44	42-189	Pocket Level	.58
33-604	Contractor Grade™ MaxSteel™ Tape Rule	.44	42-190	High Visibility Plastic Line Level	.58
33-605	Contractor Grade™ MaxSteel™ Tape Rule	.44	42-191	9" Torpedo Level	.58
33-606	Contractor Grade™ MaxSteel™ Tape Rule	.44	42-197	Contractor Grade™ Heavy Duty Double Vial I-Beam Level	.56
33-691	Contractor Grade™ MaxSteel™ Tape Rule	.44	42-224	Black I-Beam Level	.57
33-692	Contractor Grade™ MaxSteel™ Tape Rule	.44	42-240	Top Read I-Beam Level	.57
33-695	Contractor Grade™ MaxSteel™ Tape Rule	.44	42-244	Contractor Grade™ Top Read I-Beam Magnetic Level	.56
33-696	Contractor Grade™ MaxSteel™ Tape Rule	.44	42-248	Black I-Beam Level	.57
33-699	Comfort Grip Powerlock® Tape Rule	.45	42-264	9" Torpedo Level	.58
33-825	Powerlock® Tape Rule	.45	42-287	Aluminum Line Level	.58
33-835	35' Powerlock® Tape Rule	.45	42-291	8" Torpedo Level	.58
33-973	Contractor Grade™ Heavy Duty Powerlock® Tape Rule	.44	42-294	8" Torpedo Level	.58
34-095	High Visibility Long Tape	.48	42-309	I-Beam Torpedo Level	.57
34-096	High Visibility Long Tape	.48	42-311	I-Beam Torpedo Level	.57
34-251	Contractor Grade™ Heavy Duty Steel Long Tape	.48	42-321	Contractor Grade™ Brass Bound Mason's Level	.56
34-252	Contractor Grade™ Heavy Duty Steel Long Tape	.48	42-347	Contractor Grade™ Brass Bound Mason's Level	.56
34-305	Contractor Grade™ Heavy Duty Steel Long Tape	.48	42-422	Contractor Grade™ Wood I-Beam Level	.56
34-310	Contractor Grade™ Heavy Duty Steel Long Tape	.48	42-436	Silver I-Beam Level	.57
34-383	Steel Long Tape	.48	42-449	Contractor Grade™ Wood I-Beam Level	.56
34-389	Steel Long Tape	.48	42-465	Contractor Grade™ Cast Aluminum Torpedo Level	.57
34-390	Steel Long Tape	.48	42-480	Top Read I-Beam Level	.57
34-391	Steel Long Tape	.48	42-486	Contractor Grade™ Top Read I-Beam Magnetic Level	.56
34-393	Steel Long Tape	.48	42-512	Contractor Grade™ Lighted Torpedo Level	.57
34-402	Contractor Grade™ MaxSteel™ Long Tape	.48	42-748	Silver I-Beam Level	.57
34-403	Contractor Grade™ MaxSteel™ Long Tape	.48	42-824	Silver I-Beam Level	.57
34-404	Contractor Grade™ MaxSteel™ Long Tape	.48	45-011	Contractor Grade™ Aluminum Rafter Square	.58
34-450	Steel Long Tape	.48	45-012	12" Aluminum Square	.59
34-428	Contractor Grade™ MaxSteel™ Long Tape	.48	45-068	Mini-Square™ Steel Square	.59
34-500	Steel Long Tape	.48	45-119	Contractor Grade™ Steel Rafter Square	.58
34-790	Contractor Grade™ Open Reel Fiberglass Long Tape	.48	45-300	Aluminum Carpenter's Square	.59
34-791	Contractor Grade™ Open Reel Fiberglass Long Tape	.48	45-500	Steel Carpenter's Square	.59
34-792	Contractor Grade™ Open Reel Fiberglass Long Tape	.48	45-530	Steel Rafter / Roofing Square	.59
34-793	Contractor Grade™ Open Reel Fiberglass Long Tape	.48	45-600	Steel Carpenter's Square	.59
34-794	Contractor Grade™ Open Reel Fiberglass Long Tape	.48			
34-795	Contractor Grade™ Open Reel Fiberglass Long Tape	.48			
35-100	Contractor Grade™ Compulevel® Elevation Measurement System	.55			
35-338	Straight Edge	.58			
39-055	Powerlock® Key Tape	.46			

PROD. ID.	DESCRIPTION	PAGE NO.	PROD. ID.	DESCRIPTION	PAGE NO.
45-711	Contractor Grade™ Stair Gauge	.59	47-505	Contractor Grade™ 5 lb. Chalk	.63
45-720	Rafter Square Book	.58	47-671	Chalk and Reel Set	.63
45-910	Steel Rafter / Roofing Square	.59	47-672	3 Piece Layout Set	.63
45-912	Steel Square	.59	47-679	Contractor Grade™ 3 Piece Layout Set	.63
46-012	Plastic Handle Combination Square	.60	47-803	8 oz. Chalk	.63
46-017	Plastic Handle Combination Square	.60	47-804	8 oz. Chalk	.63
46-022	Contractor Grade™ 12" Slotted Blade Combination Square	.60	47-970	Contractor Grade™ Plumb Bob	.63
46-024	Combination Square	.60	47-971	Contractor Grade™ Plumb Bob	.63
46-028	Combination Square	.60	47-972	Contractor Grade™ Plumb Bob	.63
46-029	Combination Square	.60	51-098	16 oz. Fiberglass Hammer	.67
46-050	Adjustable Quick Square® Layout Tool	.61	51-099	16 oz. Fiberglass Hammer	.67
46-052	Adjustable Quick Square® Layout Tool	.61	51-110	16 oz. Jacketed Fiberglass Nail Hammer	.67
46-053	Contractor Grade™ Adjustable Quick-Square® Layout Tool	.61	51-350	Wood Handle Nail Hammer	.67
46-060	Quick Square® Pocket Square	.61	51-351	Wood Handle Nail Hammer	.67
46-064	Quick Square® Layout Tool	.61	51-352	Wood Handle Nail Hammer	.67
46-065	Quick Square® Layout Tool	.61	51-353	Wood Handle Nail Hammer	.67
46-068	Saw Glide® Layout Tool	.59	51-354	Wood Handle Nail Hammer	.67
46-071	Contractor Grade™ Quick Square® Layout Tool	.61	51-355	Wood Handle Nail Hammer	.67
46-123	Contractor Grade™ Combination Square	.60	51-356	Wood Handle Framing Hammer	.67
46-131	Contractor Grade™ 16" Combination Square	.60	51-357	Wood Handle Framing Hammer	.67
46-209	Contractor Grade™ Hardwood Try Square	.61	51-359	Wood Handle Framing Hammer	.67
46-222	Combination Square	.60	51-360	Wood Handle Framing Hammer	.67
46-322	6" Plastic Handle Mini Combination Square	.60	51-362	Wood Handle Framing Hammer	.67
46-323	Contractor Grade™ Combination Square	.60	51-440	Contractor Grade™ Jacketed Graphite Nail Hammer	.66
46-324	6" Mini Combination Square	.60	51-441	Contractor Grade™ Jacketed Graphite Nail Hammer	.66
46-502	Try / Mitre Square	.61	51-442	Contractor Grade™ Jacketed Graphite Nail Hammer	.66
46-522	Try / Mitre Square	.61	51-443	Contractor Grade™ Jacketed Graphite Nail Hammer	.66
46-702	Fine Woodworking Rosewood "T" Bevel	.62	51-444	Contractor Grade™ Jacketed Graphite Nail Hammer	.66
46-703	Fine Woodworking Rosewood Marking and Mortise Gauge	.62	51-446	Contractor Grade™ Jacketed Graphite Framing Hammer	.66
46-801	Contractor Grade™ Metal T-Bevel	.62	51-447	Contractor Grade™ Jacketed Graphite Framing Hammer	.66
46-813	Contractor Grade™ Hardwood T Bevel	.62	51-448	Contractor Grade™ Jacketed Graphite Framing Hammer	.66
46-825	Bevel	.62	51-449	Contractor Grade™ Jacketed Graphite Framing Hammer	.66
47-017	Wing Divider (Compass)	.62	51-450	Contractor Grade™ Jacketed Graphite Framing Hammer	.66
47-051	Contractor Grade™ Chalk Line Reel	.63	51-518	16 oz. Jacketed Fiberglass Nail Hammer	.67
47-061	Hardwood Marking Gauge	.62	51-613	Wood Handle Nail Hammer	.67
47-064	Styrene Marking Gauge	.62	51-616	Wood Handle Nail Hammer	.67
47-090	Single Bar Steel Marking Gauge	.62	51-713	Wood Handle Nail Hammer	.67
47-091	Double Bar Steel Marking Gauge	.62	51-716	Wood Handle Nail Hammer	.67
47-099	Contractor Grade™ Chalk Line Reel	.63	51-741	Contractor Grade™ Antivibe™ Hammer	.66
47-101	Replacement Chalk Line	.63	51-742	Contractor Grade™ Antivibe™ Hammer	.66
47-120	Contractor Grade™ Gear Driven Chalk Reel	.63	51-743	Contractor Grade™ Antivibe™ Hammer	.66
47-150	Chalk Line Reel	.63	51-744	Contractor Grade™ Antivibe™ Hammer	.66
47-200	Chalk Line Reel	.63	51-748	Contractor Grade™ Antivibe™ Hammer	.66
47-400	Stud Finder	.62	51-749	Contractor Grade™ Antivibe™ Hammer	.66
47-403	4 oz. Chalk	.63	51-750	Contractor Grade™ Antivibe™ Hammer	.66
47-404	4 oz. Chalk	.63			
47-502	Contractor Grade™ 5 lb. Chalk	.63			

PROD. ID.	DESCRIPTION	PAGE NO.	PROD. ID.	DESCRIPTION	PAGE NO.
51-753	Contractor Grade™ Antivibe™ Hammer	.66		Engineer Hammer	
51-900	Hammer Holster	.70	56-204	Contractor Grade™ Jacketed Fiberglass Engineer Hammer	.69
51-901	All Leather Hammer Holster	.70	56-208	Contractor Grade™ Jacketed Fiberglass Sledge Hammer	.69
54-004	Ball Pein Hammer	.68	56-210	Contractor Grade™ Jacketed Fiberglass Sledge Hammer	.69
54-008	Ball Pein Hammer	.68	56-212	Contractor Grade™ Jacketed Fiberglass Sledge Hammer	.69
54-012	Ball Pein Hammer	.68	56-218	Contractor Grade™ Jacketed Fiberglass Blacksmith Hammer	.69
54-016	Ball Pein Hammer	.68	56-220	Contractor Grade™ Jacketed Fiberglass Blacksmith Hammer	.69
54-024	Ball Pein Hammer	.68	56-222	Contractor Grade™ Jacketed Fiberglass Hand Drilling Hammer	.69
54-032	Ball Pein Hammer	.68	56-412	Contractor Grade™ Hickory Handle Blacksmith Hammer	.69
54-040	Ball Pein Hammer	.68	56-532	Compo-Cast® Hand Drilling Hammer	.71
54-048	Ball Pein Hammer	.68	56-702	Contractor Grade™ Hickory Handle Hand Drilling Hammer	.69
54-304	Magnetic Tack Hammer	.70	56-703	Contractor Grade™ Hickory Handle Hand Drilling Hammer	.69
54-431	Bricklayer's Wood Handle Hammer	.68	56-704	Contractor Grade™ Hickory Handle Hand Drilling Hammer	.69
54-435	Bricklayer's Wood Handle Hammer	.68	56-802	Contractor Grade™ Hickory Handle Engineer Hammer	.69
54-508	Compo-Cast® Ball Pein Hammer	.71	56-803	Contractor Grade™ Hickory Handle Engineer Hammer	.69
54-512	Compo-Cast® Ball Pein Hammer	.71	56-804	Contractor Grade™ Hickory Handle Engineer Hammer	.69
54-516	Compo-Cast® Ball Pein Hammer	.71	56-806	Contractor Grade™ Hickory Handle Sledge Hammer	.69
54-524	Compo-Cast® Ball Pein Hammer	.71	56-808	Contractor Grade™ Hickory Handle Sledge Hammer	.69
54-532	Compo-Cast® Ball Pein Hammer	.71	56-810	Contractor Grade™ Hickory Handle Sledge Hammer	.69
54-540	Compo-Cast® Ball Pein Hammer	.71	56-812	Contractor Grade™ Hickory Handle Sledge Hammer	.69
54-708	Contractor Grade™ Jacketed Graphite Ball Pein Hammer	.68	56-816	Contractor Grade™ Hickory Handle Sledge Hammer	.69
54-712	Contractor Grade™ Jacketed Graphite Ball Pein Hammer	.68	57-522	Rubber Mallet	.70
54-716	Contractor Grade™ Jacketed Graphite Ball Pein Hammer	.68	57-530	Compo-Cast® Standard Head Soft Face Hammer	.71
54-724	Contractor Grade™ Jacketed Graphite Ball Pein Hammer	.68	57-531	Compo-Cast® Standard Head Soft Face Hammer	.71
54-732	Contractor Grade™ Jacketed Graphite Ball Pein Hammer	.68	57-532	Compo-Cast® Standard Head Soft Face Hammer	.71
55-033	Nail Claw	.76	57-533	Compo-Cast® Standard Head Soft Face Hammer	.71
55-035	Nail Puller	.76	57-534	Compo-Cast® Standard Head Soft Face Hammer	.71
55-040	Combination Nail Claw and Chisel	.76	57-540	Compo-Cast® Slimline Head Soft Face Model	.71
55-045	Wonder Bar® II Pry Bar	.76	57-541	Compo-Cast® Slimline Head Soft Face Model	.71
55-112	Forged Hexagonal Steel Ripping Bar	.76	57-542	Compo-Cast® Slimline Head Soft Face Model	.71
55-118	Forged Hexagonal Steel Ripping Bar	.76	57-543	Compo-Cast® Slimline Head Soft Face Model	.71
55-124	Forged Hexagonal Steel Ripping Bar	.76	57-550	Compo-Cast® Sledge Model Soft Face Model	.71
55-130	Forged Hexagonal Steel Ripping Bar	.76	57-551	Compo-Cast® Sledge Model Soft Face Model	.71
55-136	Forged Hexagonal Steel Ripping Bar	.76	57-552	Compo-Cast® Sledge Model Soft Face Model	.71
55-146	Ripping Chisel	.76	57-554	Compo-Cast® Sledge Model Soft Face Model	.71
55-418	Forged Hexagonal Steel Ripping Bar Goose Neck Pattern	.76	57-584	Replacement Tip	.70
55-424	Forged Hexagonal Steel Ripping Bar Goose Neck Pattern	.76	57-585	Replacement Tip	.70
55-430	Forged Hexagonal Steel Ripping Bar Goose Neck Pattern	.76	57-592	Soft Face Hammer	.70
55-515	Wonder Bar® Pry Bar	.75			
55-525	Super Wonder Bar® Pry Bar	.75			
55-818	Offset Pattern Ripping Chisel	.76			
56-202	Contractor Grade™ Jacketed Fiberglass	.69			

PROD. ID.	DESCRIPTION	PAGE NO.	PROD. ID.	DESCRIPTION	PAGE NO.
57-593	Soft Face Hammer	.70	64-131	Contractor Grade™ 100 Plus® Pozidriv Screwdriver	.83
57-594	Soft Face Hammer	.70	64-132	Contractor Grade™ 100 Plus® Pozidriv Screwdriver	.83
57-595	Soft Face Hammer	.70	64-133	Contractor Grade™ 100 Plus® Pozidriv Screwdriver	.83
57-596	Soft Face Hammer	.70	64-134	Contractor Grade™ 100 Plus® Pozidriv Screwdriver	.83
58-010	Self-Centering Nail Set	.77	64-170	Contractor Grade™ 100 Plus® Pocket Screwdriver	.83
58-011	Self-Centering Nail Set	.77	64-171	Contractor Grade™ 100 Plus® Phillips Screwdriver	.82
58-013	Self-Centering Screw Hole Punch	.77	64-172	Contractor Grade™ 100 Plus® Phillips Screwdriver	.82
58-111	Nail Set	.77	64-175	Contractor Grade™ 100 Plus® Phillips Screwdriver	.82
58-112	Nail Set	.77	64-302	2 Piece Screwdriver Set	.87
58-113	Nail Set	.77	64-415L	5 Piece Screwdriver Set	.87
58-114	Nail Set	.77	64-422	Contractor Grade™ 100 Plus® Square Head Style Screwdriver	.83
58-120	Center Punch	.77	64-454	4 Piece Screwdriver Set	.87
58-230	Nail Set Pack	.77	64-457	6 Piece Screwdriver Set	.87
58-911	Contractor Grade™ Cushion Grip Nail Set	.77	64-461	Standard Blade / Standard Tip Screwdrivers	.87
58-912	Contractor Grade™ Cushion Grip Nail Set	.77	64-462	Standard Blade / Standard Tip Screwdrivers	.87
58-913	Contractor Grade™ Cushion Grip Nail Set	.77	64-463	Light Blade / Cabinet Tip Screwdrivers	.87
58-930	Contractor Grade™ 3 Piece Cushion Grip Nail Set	.77	64-464	Light Blade / Cabinet Tip Screwdrivers	.87
59-140	Rig Builders Hatchet	.70	64-465	Phillips Tip Screwdrivers	.87
59-200	Camp Axe	.70	64-466	Phillips Tip Screwdrivers	.87
59-213	Camp Axe	.70	64-551	Torx Screwdriver	.85
61-160	5 Piece Nut Driver Set	.91	64-552	Torx Screwdriver	.85
61-161	Nut Driver	.91	64-553	Torx Screwdriver	.85
61-162	Nut Driver	.91	64-554	Torx Screwdriver	.85
61-164	Nut Driver	.91	64-556	Torx Screwdriver	.85
61-805	Pro Nut Driver	.91	64-557	4 Piece Torx* Screwdriver Set	.86
61-806	Pro Nut Driver	.91	64-708	8 Piece Screwdriver Set	.86
61-807	Pro Nut Driver	.91	64-710	10 Piece Screwdriver Sets	.86
61-808	Pro Nut Driver	.91	64-840	Pocket Screwdriver	.85
61-809	Pro Nut Driver	.91	64-842	Standard Stubby Screwdriver	.85
61-810	Pro Nut Driver	.91	64-843	2 Piece Screwdriver Set	.86
61-811	Pro Nut Driver	.91	64-846	Extra Light Blade/Cabinet Tip Screwdriver	.85
61-825	6 Piece Pro Nut Driver Set	.91	64-854	4 Piece Screwdriver Set	.86
64-001	2 Piece High Visibility Screwdriver Set	.88	64-856	6 Piece Screwdriver Set	.86
64-003	4 Piece High Visibility Screwdriver Set	.88	64-864	Standard Blade/Tip Screwdrivers	.85
64-010	10 Piece Screwdriver Set	.87	64-866	Standard Blade/Tip Screwdrivers	.85
64-016	15 Piece Screwdriver Set	.87	64-868	Standard Blade/Tip Screwdrivers	.85
64-024	2 Piece Torx Screwdriver Set	.88	64-874	Square Blade Standard Tip Screwdrivers	.85
64-077	20 Piece Screwdriver Set	.86	64-876	Square Blade Standard Tip Screwdrivers	.85
64-100	Contractor Grade™ 100 Plus® Phillips Head Screwdriver	.82	64-883	Light Blade Cabinet Tip Screwdrivers	.85
64-101	Contractor Grade™ 100 Plus® Phillips Head Screwdriver	.82	64-886	Light Blade Cabinet Tip Screwdrivers	.85
64-102	Contractor Grade™ 100 Plus® Phillips Head Screwdriver	.82	64-896	Standard Blade/Tip Screwdrivers	.85
64-103	Contractor Grade™ 100 Plus® Phillips Head Screwdriver	.82	64-950	Clutch Head Screwdrivers	.85
64-104	Contractor Grade™ 100 Plus® Phillips Head Screwdriver	.82	64-951	Clutch Head Screwdrivers	.85
64-105	Contractor Grade™ 100 Plus® Phillips Head Stubby	.82	64-961	Square Tip Screwdriver	.85
			64-964	Square Tip Screwdriver	.85
			65-032	Phillips Offset Screwdriver	.90
			65-033	Offset Phillips/Slotted Screwdriver	.90
			65-320	Phillips Tip Screwdrivers	.85
			65-321	Phillips Tip Screwdrivers	.85

PROD. ID.	DESCRIPTION	PAGE NO.	PROD. ID.	DESCRIPTION	PAGE NO.
65-322	Phillips Tip Screwdrivers	.85		Cabinet Tip Screwdriver	
65-323	Phillips Tip Screwdrivers	.85	66-113	Contractor Grade™ 100 Plus® Extra Light Blade/ Cabinet Tip Screwdriver	.82
65-342	Stubby Phillips Tip Screwdriver	.85	66-114	Contractor Grade™ 100 Plus® Extra Light Blade/ Cabinet Tip Screwdriver	.82
65-901	Contractor Grade™ Rubber Grip Phillips Head Screwdriver	.81	66-116	Contractor Grade™ 100 Plus® Extra Light Blade/ Cabinet Tip Screwdriver	.82
65-902	Contractor Grade™ Rubber Grip Phillips Head Screwdriver	.81	66-118	Contractor Grade™ 100 Plus® Extra Light Blade/ Cabinet Tip Screwdriver	.82
65-903	Contractor Grade™ Rubber Grip Phillips Head Screwdriver	.81	66-160	Contractor Grade™ 100 Plus® Standard Blade/ Standard Tip Screwdriver	.82
65-905	Contractor Grade™ Rubber Grip Phillips Head Stubby Screwdriver	.81	66-161	Contractor Grade™ 100 Plus® Stubby Screwdriver	.82
66-011	Contractor Grade™ 100 Plus® Standard Blade/ Standard Tip Screwdriver	.82	66-162	Contractor Grade™ 100 Plus® Standard Blade/ Standard Tip Screwdriver	.82
66-013	Contractor Grade™ 100 Plus® Standard Blade/ Standard Tip Screwdriver	.82	66-163	Contractor Grade™ 100 Plus® Standard Blade/ Standard Tip Screwdriver	.82
66-015	Contractor Grade™ 100 Plus® Square Blade/ Standard Tip Screwdriver	.82	66-164	Contractor Grade™ 100 Plus® Standard Blade/ Standard Tip Screwdriver	.82
66-018	Contractor Grade™ 100 Plus® Square Blade/ Standard Tip Screwdriver	.82	66-166	Contractor Grade™ 100 Plus® Standard Blade/ Standard Tip Screwdriver	.82
66-039	6 Piece Jewelers Screwdriver Set	.88	66-168	Contractor Grade™ 100 Plus® Standard Blade/ Standard Tip Screwdriver	.82
66-088	Contractor Grade™ Vinyl Grip Stubby/Standard Tip Screwdriver	.81	66-170	Contractor Grade™ 100 Plus® Square Blade/ Standard Tip Screwdriver	.82
66-089	Contractor Grade™ Vinyl Grip Standard Blade/ Standard Tip Screwdriver	.81	66-172	Contractor Grade™ 100 Plus® Square Blade/ Standard Tip Screwdriver	.82
66-090	Contractor Grade™ Vinyl Grip Standard Blade/ Standard Tip Screwdriver	.81	66-174	Contractor Grade™ 100 Plus® Square Blade/ Standard Tip Screwdriver	.82
66-091	Contractor Grade™ Vinyl Grip Standard Blade/ Standard Tip Screwdriver	.81	66-176	Contractor Grade™ 100 Plus® Square Blade/ Standard Tip Screwdriver	.82
66-092	Contractor Grade™ Vinyl Grip Standard Blade/ Standard Tip Screwdriver	.81	66-178	Contractor Grade™ 100 Plus® Square Blade/ Standard Tip Screwdriver	.82
66-093	Contractor Grade™ Vinyl Grip Square Blade/ Standard Tip Screwdriver	.81	66-180	Contractor Grade™ 100 Plus® Standard Blade/ Cabinet Tip Screwdriver	.82
66-094	Contractor Grade™ Vinyl Grip Square Blade/ Standard Tip Screwdriver	.81	66-182	Contractor Grade™ 100 Plus® Standard Blade/ Cabinet Tip Screwdriver	.82
66-095	Contractor Grade™ Vinyl Grip Square Blade/ Standard Tip Screwdriver	.81	66-183	Contractor Grade™ 100 Plus® Standard Blade/ Screwdriver	.82
66-096	Contractor Grade™ Vinyl Grip Light Blade/Cabinet Tip Screwdriver	.81	66-186	Contractor Grade™ 100 Plus® Standard Blade/ Cabinet Tip Screwdriver	.82
66-097	Contractor Grade™ Vinyl Grip Light Blade/Cabinet Tip Screwdriver	.81	66-188	Contractor Grade™ 100 Plus® Standard Blade/ Cabinet Tip Screwdriver	.82
66-098	Contractor Grade™ Vinyl Grip Light Blade/Cabinet Tip Screwdriver	.81	66-401	4-Way™ Screwdriver	.88
66-101	Contractor Grade™ 100 Plus® Pocket Screwdriver	.83	66-405C	Economy 4-Way™ Screwdriver	.88
66-102	Contractor Grade™ 100 Plus® Pocket Screwdriver	.83	66-415	1/4" Hex Double Ended Bits	.88
66-103	Contractor Grade™ 100 Plus® Pocket Screwdriver	.83	66-565	Contractor Grade™ Rubber Grip 6 Piece Screwdriver Set	.81
66-110	Contractor Grade™ 100 Plus® Extra Light Blade/ Cabinet Tip Screwdriver	.82	66-801	5 Piece Magnetic Tip Screwdriver	.88
66-112	Contractor Grade™ 100 Plus® Extra Light Blade/	.82			

PROD. ID.	DESCRIPTION	PAGE NO.	PROD. ID.	DESCRIPTION	PAGE NO.
66-894	Contractor Grade™ Vinyl Grip Vinyl Coated Blade Screwdriver	.81	69-430	Fluted Torx Screwdriver	.84
68-130	Fine Woodworking Yankee® Spiral Ratcheting Screwdriver	.89	69-431	Fluted Torx Screwdriver	.84
68-131	Fine Woodworking Yankee® Spiral Ratcheting Screwdriver	.89	69-432	Fluted Torx Screwdriver	.84
68-135	Fine Woodworking Yankee® Spiral Ratcheting Screwdriver	.89	69-433	Fluted Torx Screwdriver	.84
68-233	Yankee® Spiral Ratchet Screwdriver	.89	69-434	Fluted Torx Screwdriver	.84
68-251	Tap Wrench With Yankee® Ratchet	.89	69-435	Fluted Scratch Awl/Ice Pick	.84
68-330	Yankee® Accessory Pack and Drill Point Set	.89	69-436	Fluted Tack Claw	.84
68-333	Yankee® Drill Point Set	.89	69-453	3 Piece Fluted Screwdriver Set	.84
68-371	Yankee® Ratchet Screwdriver Bit	.90	69-455	5 Piece Fluted Screwdriver Set	.84
68-372	Yankee® Ratchet Screwdriver Bit	.90	69-457	7 Piece Fluted Screwdriver Set	.84
68-377	Yankee® Ratchet Screwdriver Bit	.90	69-458	8 Piece Fluted Screwdriver Set	.84
68-400	Yankee® Offset Ratchets Slotted Screwdriver	.90	70-100	Contractor Grade™ 5" Padded Tool Belt	.109
68-402	Yankee® Offset Ratchet Slotted/Phillips Screwdriver	.90	70-101	Contractor Grade™ 5" Padded Tool Belt	.109
68-412	Yankee® Offset Ratchet Phillips Screwdrivers	.90	70-102	Contractor Grade™ 5" Padded Tool Belt	.109
68-722	1/4" Insert Bits 5 Piece Torx Set	.90	70-206	Contractor Grade™ Carpenter's Tool Pouch Set	.109
68-750	5 Piece Ratchet Screwdriver	.88	70-207	Contractor Grade™ Carpenter's Tool Pouch Set	.109
68-753	14 Piece Ratchet Screwdriver Set	.89	70-307	Contractor Grade™ Framer's Pouch with Tool Holders	.109
68-754	26 Piece Ratchet Screwdriver Set	.89	70-400	Contractor Grade™ Cordless Drill Holder	.109
69-003	Ice Pick / Scratch Awl	.91	74-438	Pocket Shears Multi-Tool	.24
69-006	Contractor Grade™ 100 Plus Scratch Awl	.83	77-001	Contractor Grade™ IntelliLevel™ Laser Rail	.52
69-007	One Piece Wood Handle Scratch Awl	.91	77-002	Beam Spreader Len	.53
69-008	Screw Hole Starter	.6, 90	77-003	Beam Splitter Len	.53
69-010	Tack Claw	.85	77-004	Tripod Adapter	.53
69-122	Wood Handle Scratch Awl	.91	77-005	IntelliTools™ Tripod	.53
69-155	Screwstart™ Tool	.91	77-007	IntelliMeasure™ Laser Estimator	.53
69-207	Hex Key Set	.90	77-008	IntelliTape™ Digital Tape Rule	.53
69-211	Hex Key Set	.90	77-009	IntelliPoint™ Plus Level	.54
69-215	Hex Key Set	.90	77-010	IntelliPoint™ Level	.54
69-216	Folding Hex Key Set	.90	77-011	IntelliTool™ Block Laser Level	.54
69-217	Folding Hex Key Set	.90	77-012	IntelliTool™ Dual Laser Level	.54
69-218	Folding Hex Key Set	.90	77-100	IntelliSensor™ Stud Sensor	.52
69-300	Clip'n Grip™ Screw Holder	.91	77-200	IntelliSensor™ Pro Stud Sensor	.52
69-401	Fluted Phillips Tip Screwdriver	.84	77-400	IntelliBeacon	.55
69-402	Fluted Phillips Tip Screwdriver	.84	77-401	IntelliEye Detector	.55
69-403	Fluted Phillips Tip Screwdriver	.84	83-159	Web Clamp	.108
69-405	Fluted Stubby Phillips Tip Screwdriver	.84	83-261	Spring Clamp	.108
69-410	Fluted Phillips Tip Pocket Clip Screwdriver	.84	83-262	Spring Clamp	.108
69-413	Fluted Cabinet Tip Screwdriver	.84	83-263	Spring Clamp	.108
69-416	Fluted Cabinet Tip Screwdriver	.84	83-362	Saw Horse Brackets	.108
69-418	Fluted Cabinet Tip Screwdriver	.84	84-090	Miniature Long Nose Plier	.106
69-422	Fluted Pocket Standard Tip Screwdriver	.84	84-091	Miniature 4" Diagonal Cutting Plier	.106
69-424	Fluted Standard Tip Screwdriver	.84	84-092	Miniature Needle Nose Plier	.106
69-425	Fluted Stubby Standard Tip Screwdriver	.84	84-093	Miniature End Nipper Plier	.106
69-426	Fluted Standard Tip Screwdriver	.84	84-094	Miniature Bent Nose Plier	.106
69-427	Fluted Standard Tip Screwdriver	.84	84-103	3 Piece Plier Set	.106
69-428	Fluted Standard Tip Screwdriver	.84	84-106	Slip Joint Plier	.106
			84-107	Slip Joint Plier	.106
			84-120	Long Nose Plier	.106
			84-121	Long Nose Plier	.106
			84-123	Long Nose Plier	.106

PROD. ID.	DESCRIPTION	PAGE NO.	PROD. ID.	DESCRIPTION	PAGE NO.
84-130	Diagonal Cutting Plier	106	86-216	3/8" Drive 3-Way Tool	96
84-131	Diagonal Cutting Plier	106	86-262	3/8" Drive 6 Point Standard Socket	96
84-133	Diagonal Cutting Plier	106	86-263	3/8" Drive 6 Point Standard Socket	96
84-137	Groove Joint Plier	107	86-264	3/8" Drive 6 Point Standard Socket	96
84-139	Groove Joint Plier	107	86-265	3/8" Drive 6 Point Standard Socket	96
84-140	Groove Joint Plier	107	86-266	3/8" Drive 6 Point Standard Socket	96
84-150	Linesman Plier	107	86-267	3/8" Drive 6 Point Standard Socket	96
84-151	Linesman Plier	107	86-268	3/8" Drive 6 Point Standard Socket	96
84-185	Fine Woodworking Carpenter's Nippers	107	86-269	3/8" Drive 6 Point Standard Socket	96
84-203	Plier	107	86-270	3/8" Drive 6 Point Standard Socket	96
84-213	Wire Stripper	107	86-281	3/8" Drive 6 Point Deep Socket	96
86-000	1/4" Drive Ratchet	94	86-282	3/8" Drive 6 Point Deep Socket	96
86-004	1/4" Drive Spinner	94	86-283	3/8" Drive 6 Point Deep Socket	96
86-006	1/4" Drive Extension	94	86-284	3/8" Drive 6 Point Deep Socket	96
86-007	1/4" Drive Extension	94	86-285	3/8" Drive 6 Point Deep Socket	96
86-011	1/4" Drive Universal Joint	94	86-286	3/8" Drive 6 Point Deep Socket	96
86-021	1/4" Drive 6 Point Standard Socket	94	86-287	3/8" Drive 6 Point Deep Socket	96
86-022	1/4" Drive 6 Point Standard Socket	94	86-288	3/8" Drive 6 Point Deep Socket	96
86-023	1/4" Drive 6 Point Standard Socket	94	86-302	3/8" Drive 6 Point Standard Metric Socket	97
86-024	1/4" Drive 6 Point Standard Socket	94	86-303	3/8" Drive 6 Point Standard Metric Socket	97
86-025	1/4" Drive 6 Point Standard Socket	94	86-304	3/8" Drive 6 Point Standard Metric Socket	97
86-026	1/4" Drive 6 Point Standard Socket	94	86-305	3/8" Drive 6 Point Standard Metric Socket	97
86-027	1/4" Drive 6 Point Standard Socket	94	86-306	3/8" Drive 6 Point Standard Metric Socket	97
86-028	1/4" Drive 6 Point Standard Socket	94	86-307	3/8" Drive 6 Point Standard Metric Socket	97
86-029	1/4" Drive 6 Point Standard Socket	94	86-308	3/8" Drive 6 Point Standard Metric Socket	97
86-030	1/4" Drive 6 Point Standard Socket	94	86-309	3/8" Drive 6 Point Standard Metric Socket	97
86-043	1/4" Drive 6 Point Deep Socket	95	86-310	3/8" Drive 6 Point Standard Metric Socket	97
86-044	1/4" Drive 6 Point Deep Socket	95	86-311	3/8" Drive 6 Point Standard Metric Socket	97
86-045	1/4" Drive 6 Point Deep Socket	95	86-312	3/8" Drive 6 Point Standard Metric Socket	97
86-046	1/4" Drive 6 Point Deep Socket	95	86-313	3/8" Drive 6 Point Standard Metric Socket	97
86-047	1/4" Drive 6 Point Deep Socket	95	86-314	3/8" Drive 6 Point Standard Metric Socket	97
86-048	1/4" Drive 6 Point Deep Socket	95	86-322	3/8" Drive 6 Point Deep Metric Socket	97
86-049	1/4" Drive 6 Point Deep Socket	95	86-323	3/8" Drive 6 Point Deep Metric Socket	97
86-101	1/4" Drive 6 Point Standard Metric Socket	95	86-324	3/8" Drive 6 Point Deep Metric Socket	97
86-102	1/4" Drive 6 Point Standard Metric Socket	95	86-325	3/8" Drive 6 Point Deep Metric Socket	97
86-103	1/4" Drive 6 Point Standard Metric Socket	95	86-326	3/8" Drive 6 Point Deep Metric Socket	97
86-104	1/4" Drive 6 Point Standard Metric Socket	95	86-327	3/8" Drive 6 Point Deep Metric Socket	97
86-105	1/4" Drive 6 Point Standard Metric Socket	95	86-328	3/8" Drive 6 Point Deep Metric Socket	97
86-106	1/4" Drive 6 Point Standard Metric Socket	95	86-329	3/8" Drive 6 Point Deep Metric Socket	97
86-107	1/4" Drive 6 Point Standard Metric Socket	95	86-380	3/8" Drive Spark Plug Socket	97
86-108	1/4" Drive 6 Point Standard Metric Socket	95	86-381	3/8" Drive Spark Plug Socket	97
86-109	1/4" Drive 6 Point Standard Metric Socket	95	86-383	3/8" Drive Torque Wrench	96
86-200	3/8" Drive Ratchet	95	86-400	1/2" Drive Ratchet	97
86-201	3/8" Drive Flex Head Ratchet	95	86-406	1/2" Drive Extension	97
86-206	3/8" Drive Extension	96	86-407	1/2" Drive Extension	97
86-207	3/8" Drive Extension	96	86-408	1/2" Drive Extension	97
86-208	3/8" Drive Extension	96	86-411	1/2" Drive Universal Joint	98
86-211	3/8" Drive Universal Joint	96	86-412	1/2" Drive Speeder	98
86-212	3/8" Drive Speeder	96	86-413	1/2" Drive Flex Handle	98
86-213	3/8" Drive Flex Handle	96	86-414	1/2" Drive Adapter	98
86-214	3/8" Drive Adapter	96	86-461	1/2" Drive 12 Point Standard Socket	98
86-215	3/8" Drive Adapter	96	86-462	1/2" Drive 12 Point Standard Socket	98

PROD. ID.	DESCRIPTION	PAGE NO.	PROD. ID.	DESCRIPTION	PAGE NO.
86-463	1/2" Drive 12 Point Standard Socket	.98	86-817	Metric Open End Wrench	.104
86-464	1/2" Drive 12 Point Standard Socket	.98	86-818	Metric Open End Wrench	.104
86-465	1/2" Drive 12 Point Standard Socket	.98	86-821	Metric Open End Wrench	.104
86-466	1/2" Drive 12 Point Standard Socket	.98	86-823	Metric Open End Wrench	.104
86-467	1/2" Drive 12 Point Standard Socket	.98	86-824	Metric Open End Wrench	.104
86-468	1/2" Drive 12 Point Standard Socket	.98	86-827	Metric Open End Wrench	.104
86-469	1/2" Drive 12 Point Standard Socket	.98	86-828	Metric Open End Wrench	.104
86-470	1/2" Drive 12 Point Standard Socket	.98	86-831	Combination Wrench	.104
86-471	1/2" Drive 12 Point Standard Socket	.98	86-832	Combination Wrench	.104
86-472	1/2" Drive 12 Point Standard Socket	.98	86-833	Combination Wrench	.104
86-473	1/2" Drive 12 Point Standard Socket	.98	86-834	Combination Wrench	.104
86-474	1/2" Drive 12 Point Standard Socket	.98	86-835	Combination Wrench	.104
86-481	1/2" Drive 12 Point Deep Socket	.98	86-836	Combination Wrench	.104
86-482	1/2" Drive 12 Point Deep Socket	.98	86-837	Combination Wrench	.104
86-483	1/2" Drive 12 Point Deep Socket	.98	86-838	Combination Wrench	.104
86-484	1/2" Drive 12 Point Deep Socket	.98	86-839	Combination Wrench	.104
86-485	1/2" Drive 12 Point Deep Socket	.98	86-840	Combination Wrench	.104
86-486	1/2" Drive 12 Point Deep Socket	.98	86-841	Combination Wrench	.104
86-487	1/2" Drive 12 Point Deep Socket	.98	86-842	Combination Wrench	.104
86-488	1/2" Drive 12 Point Deep Socket	.98	86-843	Combination Wrench	.104
86-489	1/2" Drive 12 Point Deep Socket	.98	86-844	Combination Wrench	.104
86-490	1/2" Drive 12 Point Deep Socket	.98	86-845	Combination Wrench	.104
86-491	1/2" Drive 12 Point Deep Socket	.98	86-846	Combination Wrench	.104
86-544	1/2" Drive 12 Point Standard Metric Socket	.98	86-852	Metric Combination Wrench	.104
86-545	1/2" Drive 12 Point Standard Metric Socket	.98	86-853	Metric Combination Wrench	.104
86-546	1/2" Drive 12 Point Standard Metric Socket	.98	86-854	Metric Combination Wrench	.104
86-547	1/2" Drive 12 Point Standard Metric Socket	.98	86-855	Metric Combination Wrench	.104
86-548	1/2" Drive 12 Point Standard Metric Socket	.98	86-856	Metric Combination Wrench	.104
86-549	1/2" Drive 12 Point Standard Metric Socket	.98	86-857	Metric Combination Wrench	.104
86-550	1/2" Drive 12 Point Standard Metric Socket	.98	86-858	Metric Combination Wrench	.104
86-551	1/2" Drive 12 Point Standard Metric Socket	.98	86-859	Metric Combination Wrench	.104
86-553	1/2" Drive 12 Point Standard Metric Socket	.98	86-860	Metric Combination Wrench	.104
86-554	1/2" Drive 12 Point Standard Metric Socket	.98	86-861	Metric Combination Wrench	.104
86-556	1/2" Drive 12 Point Standard Metric Socket	.98	86-862	Metric Combination Wrench	.104
86-557	1/2" Drive 12 Point Standard Metric Socket	.98	86-863	Metric Combination Wrench	.104
86-559	1/2" Drive 12 Point Standard Metric Socket	.98	86-864	Metric Combination Wrench	.104
86-580	1/2" Drive Spark Plug Socket	.98	86-866	Metric Combination Wrench	.104
86-581	1/2" Drive Spark Plug Socket	.98	86-867	Metric Combination Wrench	.104
86-583	1/2" Drive Torque Wrench	.98	86-876	Box End Wrench	.104
86-600	1/4" Drive 13 Piece Socket Set	.101	86-878	Box End Wrench	.104
86-601	3/8" Drive 20 Piece Socket Set	.101	86-881	Box End Wrench	.104
86-615	3/8" Drive 12 Piece Metric Socket Set	.101	86-883	Box End Wrench	.104
86-617	3/8" Drive 20 Piece Metric Socket Set	.101	86-884	Box End Wrench	.104
86-619	1/4" and 3/8" Drive 21 Piece Metric Socket Set	.102	86-886	Box End Wrench	.104
86-800	Open End Wrench	.104	86-907	1/4" Drive 25 Piece Standard and Deep Socket Set	.101
86-801	Open End Wrench	.104	86-918	3/8" Drive 12 Piece Socket Set	.101
86-803	Open End Wrench	.104	86-933	1/2" Drive 13 Piece Socket Set	.101
86-806	Open End Wrench	.104	86-936	1/2" Drive 18 Piece Socket Set	.101
86-808	Open End Wrench	.104	86-967	6 Piece Combination Wrench Set	.105
86-809	Open End Wrench	.104	86-968	9 Piece Combination Wrench Set	.105
86-811	Open End Wrench	.104	86-970	14 Piece Combination Wrench Set	.105

PROD. ID.	DESCRIPTION	PAGE NO.	PROD. ID.	DESCRIPTION	PAGE NO.
86-977	1/4" and 3/8" Drive 21 Piece Socket Set	102		Socket Set	
86-982	1/4" and 3/8" Drive 29 Piece Socket Set	102	87-750	3/8" Drive 10 Piece Deep Clip Rail Inch Socket Set	100
87-018	1/4" Drive Socket Clip Rail Set	94	87-751	1/2" Drive 10 Piece Standard Clip Rail Inch Socket Set	100
87-019	3/8" Drive Socket Clip Rail	96			
87-020	1/2" Socket Clip Rail	98	87-752	1/2" Drive 10 Piece Standard Clip Rail Metric Socket Set	100
87-195	1/4" and 3/8" Drive 50 Piece Socket Set	102			
87-205	3/8" Drive 16 Piece Socket Set	101	87-753	3/8" Drive 7 Piece Torx Bit Clip Rail Socket Set	100
87-207	1/4" and 3/8" Drive 39 Piece Socket Set	102	87-754	3/8" Drive 5 Piece Screwdriver Bit Clip Rail Socket Set	100
87-208	1/4" and 3/8" Drive 65 Piece Socket Set	102			
87-290	5 Piece Open End Wrench Clip Set	104	87-755	3/8" Drive 5 Piece Hex Bit Clip Rail Socket Set	100
87-366	Adjustable Wrench	107	87-820	1/4" Drive Quick Release Ratchet	94
87-368	Adjustable Wrench	107	87-830	3/8" Drive Quick Release Ratchet	95
87-405	5 Piece Combination Wrench Clip Set	104	87-840	1/2" Drive Quick Release Ratchet	97
87-454	The "Claw" Adjustable Wrench	107	87-959	6 Piece Combination Wrench Set	104
87-455	The "Claw" Adjustable Wrench	107	87-960	6 Piece Combination Wrench Set	104
87-458	The "Claw" Adjustable Wrench	107	87-961	9 Piece Combination Wrench Set	104
87-470	Adjustable Wrench	107	87-962	9 Piece Combination Wrench Set	104
87-472	Adjustable Wrench	107	87-963	5 Piece Open End Wrench Set	105
87-476	Pipe Wrench	108	87-964	5 Piece Open End Wrench Set	105
87-477	Pipe Wrench	108	90-474	2 Piece Plier and Wrench Set	107
87-478	Pipe Wrench	108	92-664	22 Piece Mechanics Tool Set	103
87-479	Pipe Wrench	108	92-665	34 Piece Mechanics Tool Set	103
87-500	1/2" Drive Impact 6 Pt. Standard Metric Socket	99	92-666	54 Piece Mechanics Tool Set	103
87-501	1/2" Drive Impact 6 Pt. Standard Metric Socket	99	93-020	Tubing Cutter	24
87-502	1/2" Drive Impact 6 Pt. Standard Metric Socket	99	93-060	Safety Goggles	70
87-503	1/2" Drive Impact 6 Pt. Standard Metric Socket	99	93-300	Panel Carry	108
87-504	1/2" Drive Impact 6 Pt. Standard Metric Socket	99	93-301	Panel Carry	108
87-505	1/2" Drive Impact 6 Pt. Standard Metric Socket	99	93-310	Contractor Grade™ Board Bender	75
87-507	1/2" Drive Impact 6 Pt. Standard Metric Socket	99	93-930	Carpenter's Pencils	108
87-508	1/2" Drive Impact 6 Pt. Standard Metric Socket	99			
87-509	1/2" Drive Impact 6 Pt. Standard Metric Socket	99			
87-510	1/2" Drive Impact 6 Pt. Standard Metric Socket	99			
87-511	1/2" Drive Impact Socket 11 Piece Set	103			
87-512	1/2" Drive Impact Socket 11 Piece Set	103			
87-515	1/2" Drive Impact 6 pt. Standard Socket	99			
87-516	1/2" Drive Impact 6 pt. Standard Socket	99			
87-517	1/2" Drive Impact 6 pt. Standard Socket	99			
87-519	1/2" Drive Impact 6 pt. Standard Socket	99			
87-520	1/2" Drive Impact 6 pt. Standard Socket	99			
87-522	1/2" Drive Impact 6 pt. Standard Socket	99			
87-557	3/4" Drive 21 Piece Ratchet/Socket Set	102			
87-710	1/4" Drive Standard Ratchet	94			
87-715	3/8" Drive Standard Ratchet	95			
87-720	1/2" Drive Standard Ratchet	97			
87-745	1/4" Drive 10 Piece Standard Clip Rail Inch Socket Set	100			
87-746	1/4" Drive 10 Piece Standard Clip Rail Metric Socket Set	100			
87-747	1/4" Drive 7 Piece Deep Clip Rail Inch Socket Set	100			
87-748	3/8" Drive 8 Piece Standard Clip Rail Inch Socket Set	100			
87-749	3/8" Drive 10 Piece Standard Clip Rail Metric	100			

STANLEY

Goldblatt

PRODUCT CATALOG

Quality trowel trade tools since 1885



STANLEY

AccuScape™
Precision Garden Tools

Shaping Your World



STANLEY

MAKE SOMETHING GREAT™

© 1998 Stanley Tools
New Britain, CT 06053

www.stanleyworks.com

T4500